

Inheritance of litter size at birth in the house musk shrew (*Suncus murinus*, Insectivora, Soricidae)

YU. S. AULCHENKO^{1,2}, S.-I. ODA³, M. B. ROGATCHEVA^{1,3}, P. M. BORODIN^{1,2}
AND T. I. AXENOVICH^{1*}

¹Institute of Cytology and Genetics, Novosibirsk, 630090, Russia

²Department of Cytology and Genetics, Novosibirsk State University, Novosibirsk, 630090, Russia

³Laboratory of Animal Management, School of Agricultural Sciences, Nagoya University, Nagoya 464-01, Japan

(Received 17 February 1997 and in revised form 15 July 1997 and 28 October 1997)

Summary

In this research we estimated the contribution of a major-gene effect to the control of litter size in hybrids between two local populations of the house musk shrew (*Suncus murinus*). Segregation analysis was performed on the basis of a mixed polygene and major-gene model. The model presumes that two parental populations may differ from each other in gene frequencies and in the values of polygenic effects but not in the major-gene contribution of the trait. Moreover, the peculiarity of the trait – litter size – is taken into account. This trait is not an individual attribute. It characterizes the parental couple and may depend on the genotypes of both parents. Results of segregation analysis of a large hybrid pedigree of *Suncus murinus* indicate that the parental populations differ in the allele frequency of the major gene (one population is homozygous, while the other contains the two alleles in approximately equal proportions) and in the values of average polygenic effects. Both major-gene and polygenic components are necessary for the correct description of litter size inheritance in interracial hybrids of *S. murinus*, inasmuch as the exclusion of either of them leads to a significant drop in likelihood. The Elston–Stewart criterion also confirms the Mendelian inheritance of the major gene.

1. Introduction

Inheritance of litter size has been extensively studied in various laboratory and farm animals (Falconer, 1960, 1963, 1989; Land, 1972, 1973, 1978; Islam *et al.*, 1976; Eklund & Bradford, 1977; Eisen & Johnson, 1981; Henderson *et al.*, 1985; Bradford *et al.*, 1986; Dilts *et al.*, 1991; Davis *et al.*, 1991; Lanneluc *et al.*, 1994; Montgomery *et al.*, 1993, 1995). It has been shown that litter size is genetically variable in outbred strains. It can be gradually increased or decreased by direct or correlated selection. These findings have been interpreted as an indication of additive polygenic control of this trait. However, genes with a large effect on fertility have been identified recently. Bradford *et al.* (1986) presented evidence for a gene with a large effect on ovulation rate and litter size in Japanese

sheep. The Booroola fecundity (*Fec*) autosomal gene in sheep was isolated and characterized in detail (Henderson *et al.*, 1985; Lanneluc *et al.*, 1994; Montgomery *et al.*, 1993, 1995). Another major gene influencing ovulation rate was found on the X chromosome of sheep (Davis *et al.*, 1991). This indicates that the inheritance of litter size can be analysed within the framework of a mixed major-gene and polygenic model.

In this research we estimated the contribution of a major-gene effect to the control of variation in litter size in the house musk shrew (*Suncus murinus*, L., Insectivora, Soricidae). This species is widely distributed throughout Asia and East Africa. The animals involved in our study originated from the crosses and intercrosses of two geographically and historically isolated *S. murinus* populations.

Hybrid analysis is a direct method for detecting genes with a large effect. It demands, however, crosses of homozygous inbred strains, which were not available in *S. murinus*. In this case we may apply the

* Corresponding author. Institute of Cytology and Genetics, Novosibirsk, 630090, Russia. Fax: 7+3832 356558. e-mail: aks@bionet.nsc.ru.

method of segregation analysis that is used in human genetics (Elston, 1992). It operates with pedigree data rather than with fixed crosses and allows us to estimate the effects of major genes.

2. Materials and methods

(i) Material

The shrews of the laboratory strains KAT, SRI and hybrid stock SK were used in this study. The KAT strain was derived from a wild population in Kathmandu, Nepal and maintained as a closed breeding colony during eight generations (Oda *et al.*, 1992). The SRI strain was derived from shrews originally captured in Sri Lanka (Ishikawa *et al.*, 1989). The SK hybrid stock was established by crossing individuals of KAT and SRI laboratory strains. The hybrids of SRI × KAT crosses were intercrossed or backcrossed with parental strains (mainly with KAT). The hybrids and their descendants were called the SK hybrid stock. Based on breeding records we constructed a pedigree involving SK animals and their SRI and KAT progenitors.

The pedigree had a very complex structure. There were 531 individuals in 601 nuclear pedigrees (mother, father and offspring). Many individuals were involved in multiple matings. The number of founders was very small: 7 KAT and 11 SRI. There were many long inbred loops in the pedigree, but brother–sister and offspring–parent loops were rare. A fragment of the pedigree is shown in Fig. 1.

(ii) Segregation analysis

We performed a complex segregation analysis using a special version of the mixed model of major-gene and polygene inheritance. Three mathematical components form the basis of segregation analysis: the penetrance function, the gene-frequency parameters and the transmission probabilities. The mixed model of inheritance assumes that a quantitative trait is under control of a major gene and a large number of additive genetic factors, and is contributed to by the environment (Elston & Stewart, 1971). These components of phenotypic variation (major-gene, the polygenic and environmental) are considered to be independent of each other.

The major-gene component is described through mean values of trait μ_g defined for each major genotype g . We assumed that the parental populations differed in the distribution of the genotypes, but not in values of μ_g . Consequently the genotype distribution should be defined separately for each population. When considering the diallelic autosomal major-gene model, assuming that both parental strains meet Hardy–Weinberg conditions, the genotype distribution can be described by the frequencies of A_1 allele in KAT and in SRI parental strains: $p(\text{KAT})$ and $p(\text{SRI})$, respectively.

It is usually assumed that polygene effects are normally distributed with a mean of zero and variance of σ_G^2 . In the case of a hybrid pedigree this assumption seems incorrect, since the average polygenic effects may be substantially different in parental populations.

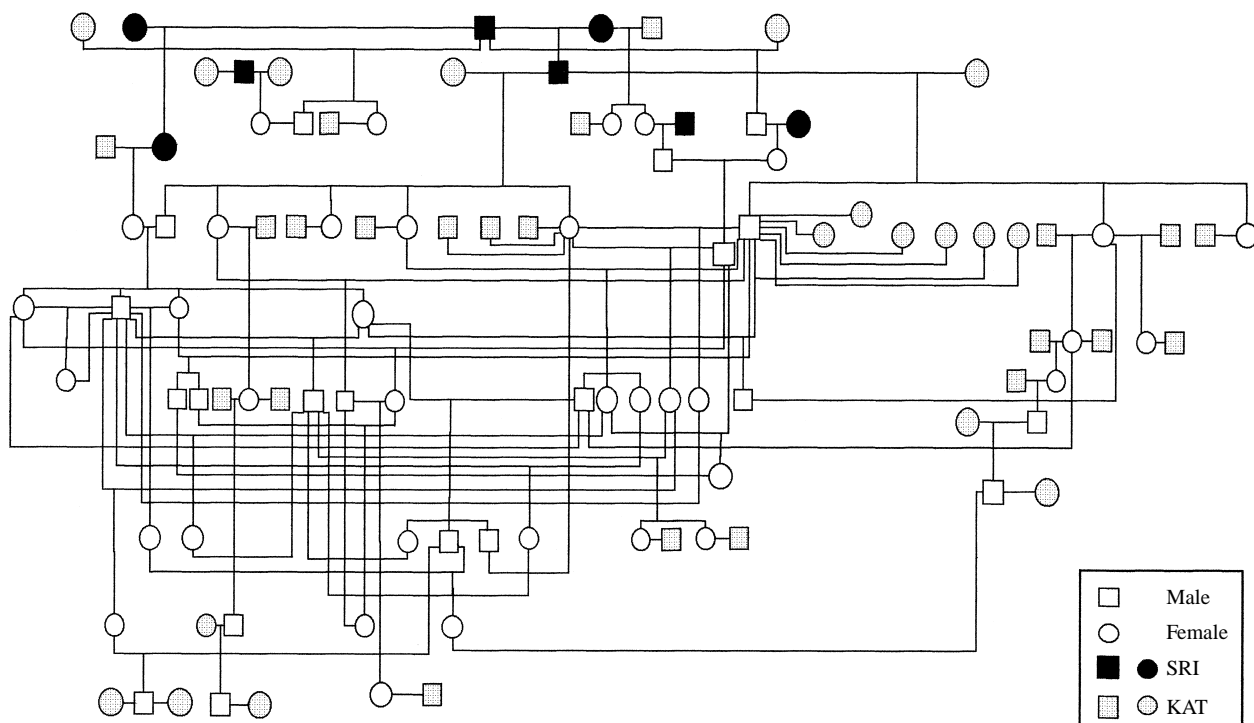

Fig. 1. A fragment of the pedigree of the SK stock of *S. murinus* involved in the analysis.

We suggested that the polygene effects are normally distributed with the same variance σ_G^2 in both populations, but the mean value for SRI is zero and that for KAT is α . Then the polygene effect G of each member of the hybrid pedigree, which is a linear function of the polygenotypes of its ancestors, might be expressed based on the blood-share of KAT (z) of this member of the hybrid pedigree ($z = 1$ for KAT parents, $z = 0$ for SRI parents, $z = 0.5$ for F_1 and F_2 , $z = 0.25$ or 0.75 for backcrosses, etc.). The polygenic effect is described as $G = \alpha z$.

We also included the heterotic effect in the model. This was proportional to the heterotic fraction h : $H = \beta h$. The heterotic fraction is equal to the proportion of heterozygous polygenic loci, which is maximal in the F_1 and half this value in the F_2 and backcrosses, etc. We suggest describing h of each individual on the basis of the blood-share of KAT in its parents (z_m and z_f for mother and father, respectively); $h = z_m(1 - z_f) + z_f(1 - z_m)$. This way of describing the heterosis fraction is similar to the method suggested by Cress (1966). The environmental component was assumed to be normally distributed with a mean of zero and variance of σ_E^2 .

Thus, the probability of the phenotypes x given the major genotype g and the blood-share of KAT z can be expressed as the density of normal distribution $\phi_x(y, \sigma^2)$ where

$$y = \mu_g + G + H = \mu_g + \alpha z - \beta h, \quad (1)$$

and $\sigma^2 = \sigma_E^2 + \sigma_G^2$ is the variance due to the environmental and polygene effects. In order not to have too many unknown parameters the variance is taken to be the same for all major genotypes (Elston, 1981).

For each triplet of major genotypes, g , g_m and g_f , the model provides a probability $p(g_m, g_f)$ that parents with genotypes g_m and g_f produce an offspring with genotype g . In the case of a monogenic diallel model this probability is described via three transmission probabilities (τ_g), i.e. probabilities of transfer of allele A_1 to offspring from the parent A_1A_1 , A_1A_2 , or A_2A_2 . When Mendelian transmission of the trait is valid, the τ_g values must be 1, 0.5 and 0 for A_1A_1 , A_1A_2 and A_2A_2 , respectively.

The estimates of the genetic parameters were obtained using the maximum likelihood method. The standard deviations of these estimates were calculated through the inverse matrix of the second derivatives of likelihood evaluated at its maximum (Kendall & Stewart, 1951).

Hypotheses were tested against a more general hypothesis using the likelihood ratio test in a hierarchical manner. Twice the natural logarithm of the likelihood ratio is distributed as χ^2 with degrees of freedom equal to the difference in number of independent parameters of the two models under comparison (Neyman & Pearson, 1928).

Segregation analysis of quantitative traits is based on the assumption that the trait is normally distributed in the population. Deviation from a normal distribution (especially skewness) may lead to spurious evidence for a major-gene effect (MacLean *et al.*, 1976; Demenais *et al.*, 1986). Therefore, a mathematical transformation of raw data is usually used to induce normality prior to analysis (MacLean *et al.*, 1976; Box & Cox, 1964). This transformation, however, has been shown to reduce the power of detection of major-gene effects within the framework of the mixed model (Demenais *et al.*, 1986). The protection against a false conclusion requires estimation of all three transmission probabilities and testing hypotheses of Mendelian and equal transmission probabilities (Demenais *et al.*, 1986). It has been shown, however, that deviation of the distribution of the phenotypes from the normal affects the results of segregation analysis only in the case of nuclear pedigrees (Moldin *et al.*, 1990; Price *et al.*, 1994), and not in the case of large complex pedigrees (Siervogel *et al.*, 1984). For all these reasons we decided to analyse non-transformed data and to perform a set of tests for a major-gene effect.

First, we compared the no-major-gene model with the mixed model. Then the hypothesis of arbitrary transmission probabilities was compared with the hypothesis of Mendelian transmission probabilities and with the hypothesis of equal transmission probabilities (Elston & Stewart, 1971; Elston, 1981). Finally, likelihoods were compared using Akaike's (1974) information criterion ($AIC = -2(\log_e LH - n)$, where LH is maximum likelihood and n is the number of independent parameters under estimation).

For this study we developed special software for segregation analysis of quantitative traits on the basis of zero-loop pedigrees of arbitrary structure coming from inter-population crosses. We used approximate calculation of the likelihood because the pedigree contained multiple loops. The major idea of our approach was to break the loops by copying some pedigree members (Lange & Elston, 1975; Stricker *et al.*, 1995). In order to minimize the errors determined by breaking loops we made the break in different ways, to give several configurations of zero-loop pedigrees. The segregation analysis has been done for each of them separately.

3. Results

(i) Non-genetic variation in litter size

The crosses were set up throughout the year, not during particular seasons. We did not detect, however, a significant dependence of litter size on the month of birth:

$$F_{526,11} = \sigma_{\text{between months}}^2 / \sigma_{\text{within months}}^2 = 0.87.$$

Table 1. Mean litter size of the parental strains KAT and SRI and their crosses

Dam	Sire	No. of litters	No. of dams	Litter size (mean \pm SE)
KAT	KAT	300	213	3.99 \pm 0.08
SRI	SRI	97	35	2.33 \pm 0.10
SRI	KAT	4	4	2.50 \pm 0.65
KAT	SRI	15	15	2.67 \pm 0.30
F1	F1	14	11	2.21 \pm 0.33
KAT	F1	19	18	3.42 \pm 0.23
F1	KAT	30	15	2.87 \pm 0.20
F1	SRI	7	5	2.43 \pm 0.37
SRI	F1	1	1	2.00

The data used in this analysis have been accumulated over several years but this did not affect the homogeneity of the data. The distribution of the average annual litter size within the parental strains did not differ significantly from the uniform distribution:

$$\chi_4^2 = 2.84 \text{ for KAT} \times \text{KAT}; \chi_6^2 = 7.15 \text{ for SRI} \times \text{SRI}.$$

This also indicates that fertility of the parental strains did not decrease because of inbreeding depression.

The females in our sample differed in the number of litters they produced. Fifty-six per cent of females were crossed only once. In those that were crossed more than once the parity effect was insignificant. The average difference between litters did not differ significantly from zero. ANOVA analysis revealed significant variation between dams versus within dams in litter size;

$$F_{147,271} = \sigma_{\text{between dams}}^2 / \sigma_{\text{within dams}}^2 = 2.09; P < 0.001.$$

Thus, the fixed effects, such as birth date and parity, can be ignored in segregation analysis.

(ii) Variation of litter size between strains and inter-strain crosses

The pedigree was very complex in its structure. There were a few crosses that corresponded to a classical hybrid scheme. Table 1 shows the mean litter size in these crosses. We should emphasize that the litter sizes for the crosses presented in Table 1 are attributed to the parents involved in the particular cross but not to their offspring. For example, the value for the cross KAT \times SRI represents the litter size of KAT females when crossed to SRI males, but not the value of their F₁ hybrids.

The litter size of KAT was almost twice that of SRI ($t_{395} = 10.87$, $P < 0.001$). It is remarkable that the litter size in KAT \times SRI crosses did not differ from that of the less fertile parent strain, SRI. In other

words, mating with an SRI male reduced the fertility of a KAT female to the level of an SRI female. The F₁ \times F₁ intercrosses also demonstrated low fertility and did not differ significantly from SRI. The mean litter sizes in KAT \times F₁ and F₁ \times KAT crosses had intermediate values and differed significantly from the litter sizes of SRI ($t_{144} = 4.24$, $P < 0.001$) and KAT ($t_{347} = 4.31$, $P < 0.001$). It is worthwhile noting that there were insignificant reciprocal differences in crosses KAT \times F₁ and KAT \times SRI: litter size was larger when the mother was KAT.

Thus, there were three distinct groups of means: (1) large litter size, which includes the cross KAT \times KAT only; (2) small litter size, comprising all crosses with SRI and F₁ \times F₁; and (3) intermediate litter size of the cross F₁ \times KAT.

Two important conclusions can be drawn from this comparison: the size of the litter produced by a female is substantially affected by her male partner; and the overall picture of the distribution of the mean values in interracial crosses fits better with the model of dominance of low fertility rather than the model of fully additive polygenic inheritance.

However, we cannot consider these data as the result of a hybrid experiment because the parental strains were not proved to be genetically homogeneous and the number of informative crosses was relatively small. For these reasons we could not analyse these crosses according to traditional statistical methods of hybrid analysis.

(iii) Segregation analysis

Litter size is a peculiar trait. It is usually considered a phenotypic characteristic of the female. Our data show that it is critically dependent on the contribution of both breeding partners. Therefore it seems more appropriate to perform the segregation analysis of the pedigree data considering litter size as the combined phenotype of the breeding couple rather than the individual phenotype of the female. Within the framework of the mixed model we suggested a general hypothesis of collaborative control of the litter size, with it dependent on the genotypes of both breeding partners (including major gene and polygenes). Hereafter we shall refer to the combination of the genotypes of a couple as a combined genotype. To describe the probability of litter size we replaced all individual phenotypes and genotypes in (1) by the combined phenotypes and genotypes. Now x is considered as the litter size of the mating pair, $z = 0.5(z_m + z_f)$ and $h = 0.5(h_m + h_f)$. Here z_m and z_f are the blood-shares of KAT for the mating individuals and h_m and h_f are their heterosis fractions.

Assuming diallel major-gene control, we expected nine combined genotypes. Then the major-gene

Table 2. Results of segregation analysis for litter size: variants of the general mode

Parameter	General 1	Non-major-gene 2	No polygene 3	No heterosis 4	Maternal-only 5	Paternal-only 6
$p(\text{KAT})$	0.41 ± 0.04	—	0.63	0.39	0.73	0.81
$p(\text{SRI})$	0.00	—	0.00	0.00	0.00	0.00
$\mu(A_1 A_1 A_1 A_1)$	4.67 ± 0.54	2.00	4.94	4.77	2.79	2.67
$\mu(A_1 A_1 A_1 A_2)$	2.34 ± 0.43	$\mu(A_1 A_1 A_1 A_1)$	3.89	2.39	$\mu(A_1 A_1 A_1 A_1)$	1.07
$\mu(A_1 A_1 A_2 A_2)$	0.18 ± 0.30	$\mu(A_1 A_1 A_1 A_1)$	2.00	0.23	$\mu(A_1 A_1 A_1 A_1)$	2.18
$\mu(A_1 A_2 A_1 A_1)$	2.32 ± 0.37	$\mu(A_1 A_1 A_1 A_1)$	3.91	2.39	1.34	$\mu(A_1 A_1 A_1 A_1)$
$\mu(A_1 A_2 A_1 A_2)$	2.79 ± 0.23	$\mu(A_1 A_1 A_1 A_1)$	4.26	2.85	$\mu(A_1 A_2 A_1 A_1)$	$\mu(A_1 A_1 A_1 A_2)$
$\mu(A_1 A_2 A_2 A_2)$	1.92 ± 0.27	$\mu(A_1 A_1 A_1 A_1)$	2.47	2.00	$\mu(A_1 A_2 A_1 A_1)$	$\mu(A_1 A_1 A_2 A_2)$
$\mu(A_2 A_2 A_1 A_1)$	0.09 ± 0.33	$\mu(A_1 A_1 A_1 A_1)$	1.77	0.15	2.19	$\mu(A_1 A_1 A_1 A_1)$
$\mu(A_2 A_2 A_1 A_2)$	0.66 ± 0.26	$\mu(A_1 A_1 A_1 A_1)$	2.28	0.66	$\mu(A_2 A_2 A_1 A_1)$	$\mu(A_1 A_1 A_1 A_2)$
$\mu(A_2 A_2 A_2 A_2)$	2.22 ± 0.08	$\mu(A_1 A_1 A_1 A_1)$	2.33	2.25	$\mu(A_2 A_2 A_1 A_1)$	$\mu(A_1 A_1 A_2 A_2)$
α	1.93 ± 0.08	1.74	[0]	2.05	1.62	1.63
β	0.69 ± 0.18	0.63	0.84	[0]	0.71	0.71
σ^2	0.78 ± 0.08	1.60	0.96	0.80	1.22	1.16
−log _e LH	961.55	994.32	974.33	968.91	975.23	983.88
AIC	1951.10	1996.64	1974.66	1963.82	1966.46	1983.76
χ^2 (d.f.)						
Compared with 1		65.54(10)*	25.56(1)*	14.72(1)*	27.36(6)*	44.66(6)*

Parameters in square brackets were fixed at the values indicated.
* $P < 0.001$.

component can be described by 12 parameters: frequencies of A_1 allele in SRI and KAT: $p(\text{SRI})$ and $p(\text{KAT})$; means of the litter size for all nine combined genotypes $\mu(g_m, g_f)$: $\mu(A_1 A_1 A_1 A_1)$, $\mu(A_1 A_1 A_1 A_2)$, $\mu(A_1 A_1 A_2 A_2)$, $\mu(A_1 A_2 A_1 A_1)$, $\mu(A_1 A_2 A_1 A_2)$, $\mu(A_1 A_2 A_2 A_2)$, $\mu(A_2 A_2 A_1 A_1)$, $\mu(A_2 A_2 A_1 A_2)$, and $\mu(A_2 A_2 A_2 A_2)$; and σ^2 , which was assumed to be the same for all genotypes. The non-major-gene component was expressed through two parameters: $\alpha \neq 0$ and $\beta \neq 0$ (see equation 1).

First we checked the necessity of a major-gene component. We specified the non-major-gene hypothesis by condition $\mu(A_1 A_1 A_1 A_1) = \mu(A_1 A_1 A_1 A_2) = \dots = \mu(A_2 A_2 A_2 A_2)$. Table 2 shows that the non-major-gene hypothesis is significantly worse than the general hypothesis ($\chi^2_{10} = 65.54, P < 0.001$). This indicates the necessity of a major-gene component in the description of the inheritance of litter size in *S. murinus*. The test for validity of Mendelism was performed: the hypothesis of arbitrary transmission probabilities was insignificantly better than that of mendelian transmission ($\chi^2_3 = 0.72$) and the hypothesis of equal transmission probabilities was definitely rejected ($\chi^2_2 = 13.86, P < 0.001$) (Table 3).

To check the difference between the parental populations in polygenic effects we excluded the polygenic-additive component from the model and set $\alpha = 0$. Table 2 shows that this procedure leads to a significant drop of likelihood in comparison with the general hypothesis. This means that the polygenic-additive component is essential for a correct description of inheritance of litter size in the pedigree under the study.

To check the significance of the heterotic effect we tested the hypothesis assuming $\beta = 0$. Table 2 shows this hypothesis to be significantly weaker than the general hypothesis. Thus, the heterotic effect cannot be neglected in the description of the inheritance of litter size.

We estimated the relative contribution of these three components, comparing AIC values obtained when we excluded one of them from the model (Table 2, hypotheses 2, 3 and 4). The most damaging was exclusion of the major-gene component.

To test the significance of collaborative genetic control of litter size two particular cases were considered: maternal-only inheritance, when litter size is assumed to be determined by the maternal genotype irrespective of the genotype of the male partner, and paternal-only inheritance.

The maternal-only model was formalized as:

$$\begin{aligned} \mu(A_1 A_1 A_1 A_1) &= \mu(A_1 A_1 A_1 A_2) = \mu(A_1 A_1 A_2 A_2), \\ \mu(A_1 A_2 A_1 A_1) &= \mu(A_1 A_2 A_1 A_2) = \mu(A_1 A_2 A_2 A_2), \\ \mu(A_2 A_2 A_1 A_1) &= \mu(A_2 A_2 A_1 A_2) = \mu(A_2 A_2 A_2 A_2), \\ z &= z_m, \text{ and } h = h_m. \end{aligned}$$

The paternal-only model was formalized as:

$$\begin{aligned} \mu(A_1 A_1 A_1 A_1) &= \mu(A_1 A_2 A_1 A_1) = \mu(A_2 A_2 A_1 A_1), \\ \mu(A_1 A_1 A_1 A_2) &= \mu(A_1 A_2 A_1 A_2) = \mu(A_2 A_2 A_1 A_2), \\ \mu(A_1 A_1 A_2 A_2) &= \mu(A_1 A_2 A_2 A_2) = \mu(A_2 A_2 A_2 A_2), \\ z &= z_f, \text{ and } h = h_f. \end{aligned}$$

A comparison of likelihoods emerged from the maternal-only and the paternal-only models, with the

Table 3. Results of segregation analysis for litter size: the Elston–Stewart test

Parameter	Mendelian τ^a 7	Arbitrary τ 8	Equal τ 9
$p(\text{KAT})$	0.41 ± 0.04	0.44	0.92
$p(\text{SRI})$	0.00	0.00	0.00
$\mu(A_1 A_1 A_1 A_1)$	4.67 ± 0.54	4.64	2.78
$\mu(A_1 A_1 A_1 A_2)$	2.34 ± 0.43	2.33	0.96
$\mu(A_1 A_1 A_2 A_2)$	0.18 ± 0.30	0.08	2.12
$\mu(A_1 A_2 A_1 A_1)$	2.32 ± 0.37	2.46	0.76
$\mu(A_1 A_2 A_1 A_2)$	2.79 ± 0.23	2.76	1.67
$\mu(A_1 A_2 A_2 A_2)$	1.92 ± 0.27	1.91	1.36
$\mu(A_2 A_2 A_1 A_1)$	0.09 ± 0.33	0.13	2.37
$\mu(A_2 A_2 A_1 A_2)$	0.66 ± 0.26	0.72	2.02
$\mu(A_2 A_2 A_2 A_2)$	2.22 ± 0.08	2.22	2.80
α	1.93 ± 0.08	1.93	1.73
β	0.69 ± 0.18	0.68	0.72
σ^2	0.78 ± 0.08	0.78	0.93
$\tau(A_1 A_1)$	[1.0]	1.00	0.82
$\tau(A_1 A_2)$	[0.5]	0.42	$\tau(A_1 A_1)$
$\tau(A_2 A_2)$	[0.0]	0.00	$\tau(A_1 A_1)$
$-\log_e LH$	961.55	961.19	968.12
AIC	1951.10	1956.38	1966.24
χ^2 (d.f.)			
Compared with 8	0.72(3)		13.86(2)*

Parameters in square brackets were fixed at the values indicated.

* $P < 0.001$.

^a Most parsimonious by AIC.

likelihood obtained from the general collaborative model indicating that the latter provides a significantly better description of inheritance ($\chi_6^2 = 27.36$, $P < 0.001$; $\chi_6^2 = 44.66$, $P < 0.001$) (Table 2).

The accuracy of LH approximation was accessed in the following way. We tested the dependence of the results of segregation analysis on the way of breaking pedigree loops. To do this testing, we made a replicated analysis of the pedigree data obtained after several different breaks. The variation in the estimates of the genetic parameters between replicates was found to be close to those within replicates. For example, the standard deviations of the genetic parameters of model 1 within replicates were 0.04 for $p(\text{KAT})$, 0.54 for $\mu(A_1 A_1 A_1 A_1)$, 0.43 for $\mu(A_1 A_1 A_1 A_2)$, 0.30 for $\mu(A_1 A_1 A_2 A_2)$, 0.37 for $\mu(A_1 A_2 A_1 A_1)$, 0.23 for $\mu(A_1 A_2 A_1 A_2)$, 0.27 for $\mu(A_1 A_2 A_2 A_2)$, 0.33 for $\mu(A_2 A_2 A_1 A_1)$, 0.26 for $\mu(A_2 A_2 A_1 A_2)$, 0.08 for $\mu(A_2 A_2 A_2 A_2)$, 0.08 for σ^2 , 0.08 for α and 0.18 for β (Table 3). Those between replicates were 0.02, 0.21, 0.16, 0.06, 0.26, 0.16, 0.09, 0.30, 0.27, 0.02, 0.02, 0.08 and 0.46, respectively.

Thus the inheritance of litter size in the hybrid *S. murinus* could be described within the framework of a mixed model of major-gene and polygenic inheritance. One of the parental strains (SRI) is homogeneous for the A_2 allele; the other (KAT) contains this allele at a frequency of about 0.6. The difference between the

parental strains in the polygenic contribution in the litter size is about 2 offspring, while the maximal heterotic effect is about 0.7 offspring.

4. Discussion

The results of segregation analysis indicate that the inheritance of litter size in interracial hybrids of *S. murinus* can be described within the framework of mixed polygene and major-gene model. The major gene follows the rules of Mendelian segregation.

We showed that a major-gene component is necessary. First, when we excluded it from the mixed model, we found a significant decrease in the likelihood. Second, the significance of the major-gene component was proved by the Elston–Stewart test. Third, the hypothesis that gave the minimal AIC contained a major-gene component. We found that the relative contribution of the major-gene component was much more substantial than that of the polygene component. Exclusion of the polygene component from the mixed model led to a smaller decrease in the likelihood than the same operation with a major-gene component.

This means that there is a major gene that makes a main contribution to the variation of litter size in the sample we analysed, whereas the effects of other genes are less substantial. Together with environmental

effects, they cannot overshadow the effect of the major gene. This is in agreement with recent findings on genetics of fertility in sheep, where several major genes responsible for litter size have been found (Henderson *et al.*, 1985; Bradford *et al.*, 1986; Davis *et al.*, 1991; Montgomery *et al.*, 1993, 1995; Lanneluc *et al.*, 1994).

The most intriguing aspect of our model is the collaborative effect. How can the combination of alleles of the same locus in male and female partners affect the size of the litter produced by the female? One may suggest that the major gene controls the viability of zygotes or embryos. Then the number of subvital alleles of whatever (paternal or/and maternal) origin affects survival of zygotes or embryos. In this case the litter size at birth would depend on the genotypes of both parents. However, due to selective mortality of the embryos within the litter, the transmission probabilities would differ from Mendelian expectation. We did not find, however, a significant deviation of the transmission probabilities from the Mendelian ones. Therefore this suggestion seems to be questionable.

There is evidence of a male influence on litter size. Dilts *et al.* (1991) detected a strong effect of the male partner on ovulation rate in the female and pre- and post-implantation survival of embryos in mice. When males from different lines selected for large litter size were mated to females from different stocks, there were more than two additional eggs, implants and pups compared with the results of mating to males from the same line as the female.

There is some evidence of the similarity of genetic systems controlling fertility in males and females. It has been shown that testis weight in mice selected for increased or decreased ovulation rate diverged in the same direction as the ovulation rate (Land, 1973). Selection for testis weight in mice resulted in a positive correlated response in ovulation rate (Islam *et al.*, 1975). Eisen & Johnson (1981) demonstrated correlated responses in male reproductive traits in mice selected for litter size. A correlation between testis growth and ovulation rate was found in different breeds of sheep (Land, 1972, 1973). It was concluded that selection for testis size had affected the feedback control of gonadotrophin release in the ewe, as in the ram, and hence the expression of the genes controlling this is not sex limited. The quantitative physiological study of genetic variation in reproductive performance has shown that differences in litter size and incidence of lambing in sheep are associated with variation in the release of luteinizing hormone. This variation is detectable in young animals of both sexes. In the male it is associated with variation in mating behaviour and testis growth (Land *et al.*, 1979). These data indicate that reproductive performance of males and females may be controlled by a similar or the same genetic system acting via the hypothalamic–pituitary axis.

Models of fertility with contributions from the genotypes of both partners have been suggested in theoretical evolutionary genetics and discussed long ago. Penrose (1949) considered fertility as a sum of components from the male and female parents, with the contribution depending only on the genotype and not on the sex of the participants in the mating. Bodmer (1965) introduced multiplicative contributions from the participants to the fertility of the mating. The third model, introduced by Haderer & Liberman (1975) and developed by Feldman & Liberman (1985) and Clark & Feldman (1986), had symmetric fertilities depending only on the number of heterozygous loci participating in the mating. None of these models has ever been tested on empirical data. The analytical tractability was the sole proof of their validity.

Our collaborative model is in essence another version of the fertility model where fertility is determined by the genotypes of both parents. The peculiarity of our model is that it was not constructed *a priori*, but resulted from a segregation analysis of empirical data.

This work was supported by research grants from the Ministry of Education, Science, Sports and Culture of Japan and major Russian Fund for Basic Research (9615-97738). M.B.R. was in receipt of a scholarship from the Government of Aichi Prefecture. Y.S.A. was in receipt of a scholarship from the International Soros Science Education Program (s97-2264).

References

- Akaike, H. (1974). A new look at the statistical model identification. *IEEE Transactions on Automatic Control* **19**, 716–723.
- Bodmer, W. F. (1965). Differential fertility in population genetics models. *Genetics* **51**, 411–424.
- Box, A. E. P. & Cox, D. R. (1964). An analysis of transformations. *Journal of the Royal Statistical Society* **B26**, 211–252.
- Bradford, G. E., Quirke, J. F., Sitorus, P., Inoune, I., Tiesnamurti, B., Bell, F. L., Fletcher, I. C. & Torell, D. T. (1986). Reproduction in Javanese sheep: evidence for a gene with large effect on ovulation rate and litter size. *Journal of Animal Science* **63**, 418–431.
- Clark, A. G. & Feldman, M. W. (1986). A numerical simulation of the one-locus multiple-allele fertility model. *Genetics* **113**, 229–253.
- Cress, C. E. (1966). Heterosis of the hybrid related to gene frequency differences between two populations. *Genetics* **53**, 269–274.
- Davis, G. H., McEwan, J. C., Fennessy, P. F., Dodds, K. G. & Farquhar, P. A. (1991). Evidence for the presence of a major gene influencing ovulation rate on the X chromosome of sheep. *Biology of Reproduction* **44**, 620–624.
- Deménils, F., Lathrop, M. & Lalouel, J. M. (1986). Robustness and power of the unified model in the analysis of quantitative measurements. *American Journal of Human Genetics* **38**, 228–234.
- Dilts, R. B., Famula, T. R. & Bradford, G. E. (1991).

- Ovulation rate and pre- and postimplantation survival in mice with a major gene for rapid postweaning gain. *Journal of Animal Science* **69**, 3590–3596.
- Eisen, E. J. & Johnson, B. H. (1981). Correlated responses in male reproductive traits in mice selected for litter size and body weight. *Genetics* **99**, 513–524.
- Eklund, J. & Bradford, G. E. (1977). Genetic analysis of a strain of mice plateaued for litter size. *Genetics* **85**, 529–542.
- Elston, R. C. (1981). Segregation analysis. *Advances in Human Genetics* **11**, 63–120.
- Elston, R. C. (1992). Segregation and linkage analysis. *Animal Genetics* **23**, 59–62.
- Elston, R. C. & Stewart, J. A. (1971). General model for the genetic analysis of pedigree data. *Human Heredity* **21**, 523–542.
- Falconer, D. S. (1960). The genetics of litter size in mice. *Journal of Cellular and Comparative Physiology* **56** (Supplement 1), 153–167.
- Falconer, D. S. (1963). Quantitative inheritance. In *Methodology in Mammalian Genetics* (ed. W. J. Burdette), pp. 193–216. San Francisco: Holden-Day.
- Falconer, D. S. (1989). *Introduction to Quantitative Genetics*, 3rd ed. Harlow: Longman Scientific and Technical.
- Feldman, M. W. & Liberman, U. (1985). A symmetric two-locus fertility model. *Genetics* **109**, 229–253.
- Hadeler, K. P. & Liberman, U. (1975). Selection model with fertility differences. *Journal of Mathematical Biology* **2**, 19–32.
- Henderson, K. M., Kieboom, L. E., McNatty, K. P., Lun, S. & Heath, D. (1985). Gonadotrophin-stimulated cyclic AMP production by granulosa cells from Booroola × Romney ewes with and without a fecundity gene. *Journal of Reproduction and Fertility* **75**, 111–120.
- Ishikawa, A., Akadama, I., Namikawa, T. & Oda, S. (1989). Development of a laboratory line (SRI line) derived from the wild house musk shrew, *Suncus murinus*, indigenous to Sri Lanka. *Experimental Animals* **38**, 231–237.
- Islam, A. B. M. M., Hill, W. G. and Land, R. B. (1976). Ovulation rate in lines of mice selected for testis weight. *Genetical Research* **27**, 23–32.
- Kendall, M. G. & Stewart, A. (1951). *The Advanced Theory of Statistics*. London: Charles Griffin.
- Land, R. B. (1972). Is mammalian fertility sex limited? *Journal of Reproduction and Fertility* **31**, 512–513.
- Land, R. B. (1973). The expression of female sex-limited characters in the male. *Nature* **241**, 208–209.
- Land, R. B. (1978). Selection among males for the genetic improvement of female fertility. *Journal of Animal Science*, **47** (Supplement 2), 48–55.
- Land, R. B., Carr, W. R. & Thompson, R. (1979). Genetic and environmental variation in the LH response of ovariectomized sheep to LH-RH. *Journal of Reproduction and Fertility* **56**, 243–248.
- Lange, K. & Elston, R. C. (1975). Extension to pedigree analysis. I. Likelihood calculations for simple and complex pedigrees. *Human Heredity* **25**, 95–105.
- Lanneluc, I., Drinkwater, R. D., Elsen, J. M., Hetzel, D. J., Nguyen, T. C., Piper, L. R., Thimonier, J., Harrison, B. & Gellin, J. (1994). Genetic markers for the Booroola fecundity (*Fec*) gene in sheep. *Mammalian Genome* **5**, 26–33.
- MacLean, C. J., Morton, N. E., Elston, R. C. & Yee, S. (1976). Skewness in commingled distributions. *Biometrics* **32**, 695–699.
- Moldin, S. O., Rice, J. P., Gottesman, I. I. & Erlenmeyer-Kimling, L. (1990). Transmission of a psychometric indicator for liability to schizophrenia in normal families. *Genetic Epidemiology* **7**, 163–176.
- Montgomery, G. W., Crawford, A. M., Penty, J. M., Dodds, K. G., Ende, A. J., Henry, H. M., Pierson, C. A., Lord, E. A., Galloway, S. M. & Schmack, A. E. (1993). The ovine Booroola fecundity gene (*FecB*) is linked to markers from a region of human chromosome 4q. *Nature Genetics* **4**, 410–414.
- Montgomery, G. W., Penty, J. M., Lord, E. A. & Broom, M. F. (1995). The search for the Booroola (*FecB*) mutation. *Journal of Reproduction and Fertility Supplement* **49**, 113–121.
- Neyman, J. & Pearson, E. S. (1928). On the use and interpretation of certain test criteria for the purposes of statistical inference. *Biometrika* **20A**, 175–263.
- Oda, S., Koyasu, K. & Shrestha, K. C. (1992). Breeding of the house musk shrew, *Suncus murinus* originating from a wild population in Kathmandu, Nepal. *Annals of the Research Institute of Environmental Medicine* **43**, 239–240.
- Penrose, L. S. (1949). The meaning of fitness in human populations. *Annals of Eugenics*, **14**, 301–304.
- Price, R. A., Charles, M. A., Pettit, D. J. & Knowler, W. C. (1994). Obesity in Pima Indians: genetic segregation analyses of body mass index complicated by temporal increases in obesity. *Human Biology* **66**, 251–274.
- Siervogel, R. M., Weinshilboum, R., Wilson, A. F. & Elston, R. C. (1984). Major gene model for the inheritance of catechol-O-methyltransferase activity in five large families. *American Journal of Medical Genetics* **19**, 315–323.
- Stricker, C., Fernando, R. L. & Elston, R. C. (1995). An algorithm to approximate the likelihood for pedigree data with loops by cutting. *Theoretical and Applied Genetics* **91**, 1054–1063.