

2013

Neuroscience
November 9–13, 2013
San Diego, CA
www.sfn.org/am2013

2013 MRS Fall Meeting

December 1–6, 2013
Boston, MA
www.mrs.org/fall2013

ASCB Annual Meeting

December 14–18, 2013
New Orleans, LA
www.ascb.org/meeting

2014

Quantitative BioImaging Conference
January 9–11, 2014
University of New Mexico, Albuquerque, NM
www.quantitativebioimaging.com

Human Amyloid Imaging Conference

January 15–17, 2014
Miami, FL
www.worldeventsforum.com/hai

ACMM23 and ICONN 2104

February 2–6, 2014
Adelaide, Australia
www.aomevents.com/ACMMICONN

Pittcon '14

March 2–7, 2014
Chicago, IL
www.pittcon.org

Microscopy & Microanalysis 2014

August 3–7, 2014
Hartford, CT
www.microscopy.org

2015

Microscopy & Microanalysis 2015
August 2–6, 2015
Portland, OR
www.microscopy.org

2016

Microscopy & Microanalysis 2016
July 24–28, 2016
Columbus, OH
www.microscopy.org

2017

Microscopy & Microanalysis 2017
July 23–27, 2017
St. Louis, MO
www.microscopy.org

2018

Microscopy & Microanalysis 2018
August 5–9, 2018
Baltimore, MD
www.microscopy.org

More Meetings and Courses

Check the complete calendar near the back of this magazine and in the MSA journal *Microscopy and Microanalysis*.

Stick Tight!

Stephen W. Carmichael

Mayo Clinic, Rochester, MN 55905

carmichael.stephen@mayo.edu

The rocky intertidal zone is an extreme environment with high, variable forces from crashing waves and strong ocean currents. A family of fishes, including the northern clingfish (*Gobiesox maeandricus*), has evolved an adhesive disc that allows them to adhere to rocks in the intertidal zone and even launch predatory attacks on molluscs that are attached to the rocks (Figure 1). Dylan Wainwright, Thomas Kleinteich, Anja Kleinteich, Stanislav Gorb, and Adam Summers studied the morphology of this fish disc to understand the properties of a reversibly adhesive disc that has a strong tenacity to stick to irregular, slippery, and wet surfaces [1].

Functional studies by Wainwright et al. compared the adhesive forces of the clingfish disc to manufactured suction cups of different sizes. The force of clingfish adhesion varied between 80 and 230 times the body weight of the fish. Manufactured suction cups had a higher peak stress (maximum force per area) than the clingfish discs on very smooth surfaces. However, the manufactured discs failed to adhere to surfaces that had a grit size more than 22 microns, which would correspond with fine sandpaper. The clingfish disc was able to adhere to surfaces with a grit size of over 250 microns, corresponding to very rough sandpaper that would be used for removing the finish from flooring!

Scanning electron microscopy (SEM) was employed to study the epithelial microstructure of the adhesive disc. The SEM revealed that papillae on the ventral face of the suction disc are arranged as a tiled surface with narrow channels between them. These papillae were identified as a hierarchically structured material with numerous microvilli. The microvilli of clingfish were of similar size (0.2 μm) to the adhesive setae of certain spiders and geckos. This morphology



Figure 1: Photograph of a northern clingfish adhering to a rock, courtesy of Thomas Kleinteich.



Systems smart enough to help you reach the summit.

At EDAX we understand how you see the world. Tackle your next materials challenge with one of our **TEAM™ Trident Analysis Systems**, the industry's most comprehensive microanalysis solution.

- EDS, EBSD and WDS seamlessly integrated with a single user interface.
- Built-in Smart Features facilitate set-up, guide analysis and automate reporting.
- Proven algorithms guarantee quality results.
- Streamlined workflows drive productivity with industry-best results in three mouse clicks.

Find out how to power your next insight with EDAX at edax.com/smart/



that allows diverse animals to cling to surfaces provides a striking case of convergent evolution.

Wainwright et al. suggested that the hierarchical structure of the clingfish disc allows the edges of the disc to interdigitate with rough features of a furrowed surface. This interdigitation increases friction at the edge of the disc over surface irregularities, allowing exceptional adhesive performance of rough surfaces. This view is supported by the surprising finding that the clingfish disc adhered poorly on a very smooth surface. This is probably due to a loss of friction that allows the edges of the disc to slide toward the center and fail to stick.

In conclusion, Wainwright et al. suggest that the morphology of the clingfish disc presents a potential biomimetic model for improving adhesion to rough surfaces. If engineers could design a compliant, hierarchical surface at the edges of an attachment device, a much-improved suction cup could be manufactured.

References

- [1] DK Wainwright, T Kleinteich, A Kleinteich, SN Gorb, and AP Summers, *Biol Lett* 9 (2013) 20130234.
- [2] The author gratefully acknowledges Dr. Adam Summers for reviewing this article.

MT

a powerful, multi-color, solid-state illuminator

why buy a lamp when you can have a light engine?

solid state sources, more power than an Arc Lamp and

- White light and narrow band outputs
- Six independent sources within UV-Vis-NIR
- User exchangeable filters
- Spectral and power stability
- Illumination uniformity
- Electronic shuttering
- Microsecond switching times
- Minimal heat generation
- Computer control of independent outputs
- Long life > 20,000 hours, 36 month warranty
- Off-the-shelf and OEM configurations
- Custom OEM requests encouraged
- Optical design services available, please inquire

specific outputs are a function of instrument parameters
results will vary

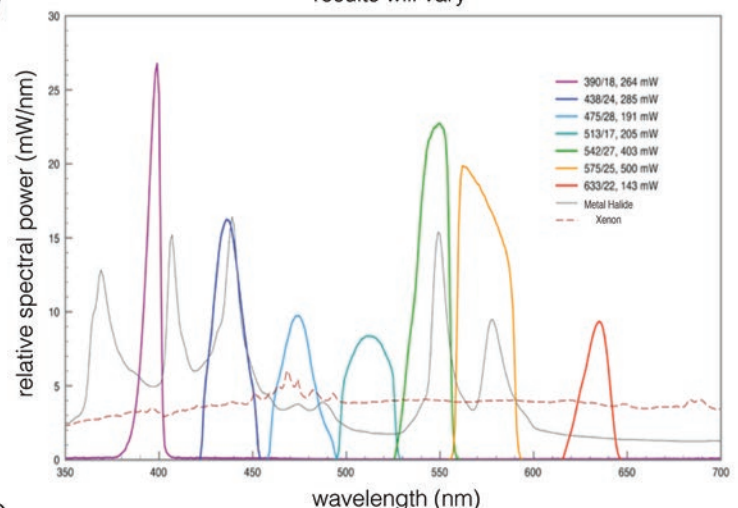

Lumencor, Inc. 14964 NW Greenbrier Parkway, Beaverton, OR 97006 USA **E** info@lumencor.com www.lumencor.com

Cathodoluminescence for SEM, and now for TEM

Imaging & Spectroscopy Optoelectronics Plasmonics Semiconductor Geological

Published online by Cambridge University Press

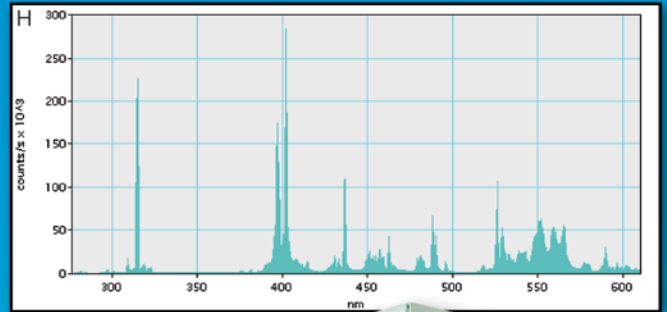
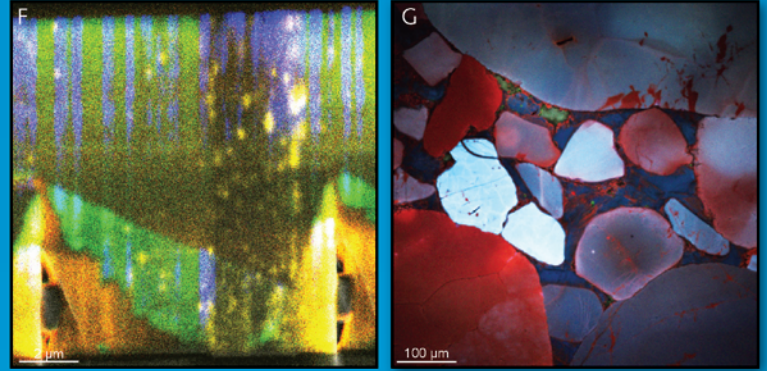
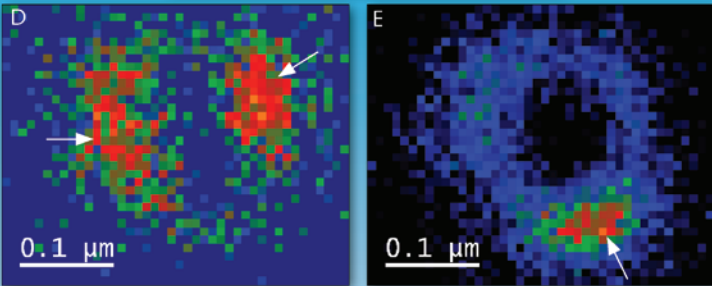
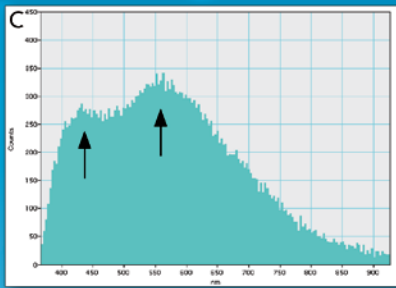
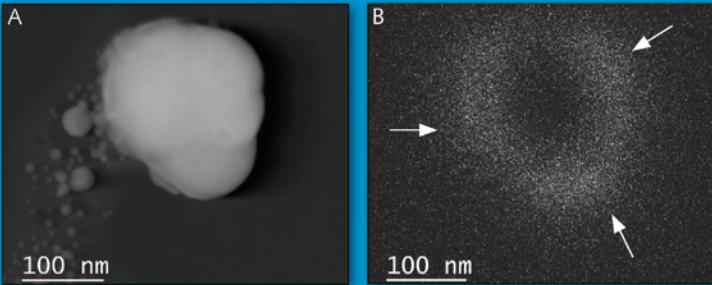
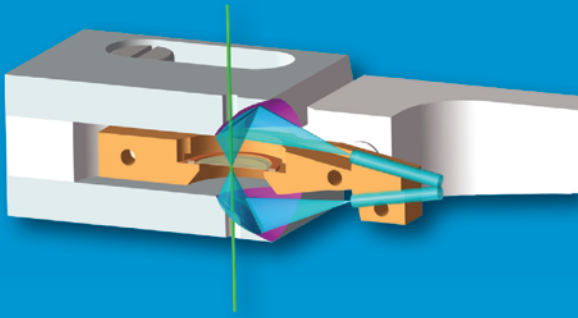

Top Image: Schematic cross section through the Vulcan™ holder showing the specimen region and top and bottom collection mirrors (mirrored surface shown in purple). An electron beam (green) stimulates the specimen to emit photons (blue) which are focused by the collection mirrors into optical fibres situated away from the specimen region. Bottom Images A-E: CL study of colloidal silver nanoparticle; A) HAADF image; B) panchromatic CL image (acquired simultaneously to the HAADF image) displaying three 'bright' resonance nodes (indicated by arrow markers); C) cathodoluminescence spectrum with two peaks corresponding to spectrally discrete resonance modes at 430 and 510 nm; D) and E) cathodoluminescence band pass images at 430 and 550 nm ±40 nm extracted from parent spectrum-image showing resonance modes are separated spatially and spectrally.

Images F-H: F) GaN film in cross section imaged with Gatan MonoCL4™ CL imaging and spectroscopy system. Composite image of stacking fault, threading dislocation, point defect and band gap luminescence. Temperature = 6 K; G) quartz arenite polished section cathodoluminescence image prepared using the Gatan Ikon™ and imaged with Gatan ChromaCL2™ imaging system. Image courtesy of Dr. J. Schieber, Indiana University; H) Cathodoluminescence spectrum from lanthanide doped yttrium aluminium garnet single crystal acquired at room temperature. Multiple spectral features corresponding to various Eu³⁺ d to f orbital electron transitions observed. Bottom image: MonoCL4™ Elite CL imaging and spectroscopy system.

Vulcan
Cathodoluminescence Detection and Analysis for Scanning TEMs

MonoCL4

Cathodoluminescence Imaging and Spectroscopy System for the SEM

ChromaCL2

Live Color Cathodoluminescence Imaging in the SEM

Enhancing Electron Microscopy



www.gatan.com