

the assembly process, SOPV first forms unstructured clusters, which ultimately grow into neatly organized left-handed “spiral staircase”-like helical structures. Detailed time-resolved investigation

of this assembly process importantly showed that at early reaction times, aggregates with the opposite helicity were also present. These right-handed helices are metastable and convert to the ther-

modynamically favored left-handed helices with time.

Aggregation of SOPV therefore involves two competing pathways which lead to assemblies with opposite helicity, one of which is favored kinetically and the other thermodynamically. Based on this understanding, the researchers demonstrated that the assembly process could be controlled to uniquely select the kinetic product. Addition of tartaric acid, a small molecule that attaches itself to the SOPV molecules, forces the assembly process toward the right-handed helices.

“This knowledge has significant impact on an optimal self-assembly process, and we can now use it for more applied supramolecular systems which are much more difficult to study,” said Korevaar.

Nano Focus

Nanoscale transistor measures living cell voltages

Forming an electrical interface with living cells, including muscle cells and neurons, is crucial for studying fundamental electrophysiological processes. These cells use ion-transport channels to create a potential difference across their membrane (action potentials) that can be used to convey a nerve signal or trigger muscle contraction. In order to measure these potentials with high spatial precision and minimal cell disturbance, the research team of C.M. Lieber at Harvard University recently developed a nanowire field-effect transistor (FET) that employs a branched silica nanotube as a nanoscale syringe.

Their article in the December 18 advanced online issue of *Nature Nanotechnology* (DOI: 10.1038/NNANO.2011.223) describes the formation of silica nanotubes using germanium nanowires as a sacrificial template, themselves grown radially out from a silicon nanowire substrate. After depositing metal sources and drain electrodes on the silicon on either side of the germanium nanowires, the whole structure is coated in SiO₂ and the ger-

manium nanowires are removed by chemical etching. This leaves tapering silica nanotubes several micrometers in length and 50–150 nm in diameter that allow imbibed liquid to contact the silicon channel between the electrodes. The conductance in solution of transistors constructed using the nanotubes was much more sensitive to changes in applied voltages than those prepared with solid germanium. This demonstrates that the solution in the hollow tube was responsible for the gate voltage experienced by the nanowire, and that this cavity could therefore serve as an effective cellular probe.

The device was used to study the action potentials in a culture of cardiomyocytes (heart muscle cells), after first modifying the nanotube with phospholipids to improve its interaction with the cell membrane. Upon contact with a cell, the nanotube spontaneously penetrated the membrane and filled with cytosol, and a clear trace of the intracellular action potential typical of beating cardiomyocytes could be recorded by the transistor.

A principal advantage of these devices over existing techniques using

glass micropipettes which form the basis of the “patch clamp” technique is that they appear to interfere minimally with the cell. A biomimetic seal provided by

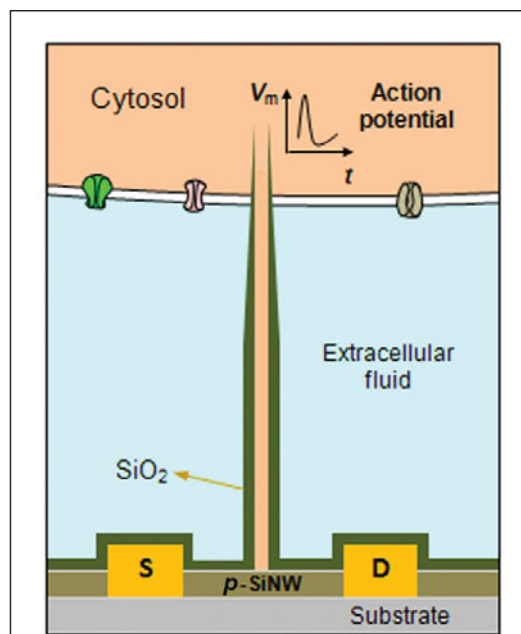

A schematic diagram of a cell coupled to the branched nanotube field-effect transistor during an action potential V_m . S and D indicate source and drain electrodes. Reproduced with permission from *Nature Nanotech.*, DOI: 10.1038/NNANO.2011.223. © 2011 Macmillan Publishers Ltd.



Fuel for Your Research

All Things Vacuum

KJLC® offers the most comprehensive inventory of pure elements, alloys, advanced metal oxides and compounds fabricated to meet the most demanding physical vapor deposition process requirements.

- Largest Target and Evaporation Materials Inventory
- Custom Compositions, Purities and Quantities
- Unmatched Service and Technical Support

 **MATERIALS™**
DIVISION

www.lesker.com



the phospholipid coating prevents leakage and provides both a steady signal over time and cell viability after the measurement. The ease of fabricating several

independent devices also allowed the team to make simultaneous measurements on the same cell or at multiple sites on a cell monolayer. With the poten-

tial for attaining dimensions as small as 5 nm, these devices could become a useful new tool in electrophysiology.

Tobias Lockwood

Inverse spin Hall effect observed in silicon

Designers of next-generation electronics are trying to take advantage of both the electron's charge and spin. The success of spintronic devices therefore hinges on the ability to convert between spin and charge currents. The direct spin Hall effect is typically used to probe spin-orbit coupling in these materials, but the technique cannot be applied to semiconductors with long spin lifetimes, such as indirect bandgap silicon. Researchers Kazuya Ando and Eiji Saitoh at Tohoku University in Sendai, Japan, have turned their attention to the inverse spin Hall effect (ISHE), which makes use of the high resistivity of semiconductors to detect tiny spin currents. Ando and Saitoh show that it is possible to study spin-orbit interactions using ISHE in otherwise unmeasurable systems.

As reported in the January 17 issue of the online journal *Nature Communications* (DOI: 10.1038/ncomms1640), the researchers first deposited a thin-film heterostructure of $\text{Ni}_{81}\text{Fe}_{19}/\text{B-doped Si}$ onto a silicon-on-insulator substrate and laid down ohmic AuPd contacts to detect the in-plane Hall voltage. They then measured the voltage across

the AuPd contacts with a magnetic field applied at 0° and 180° normal to the plane of the sample. They found that the Hall voltage depends on the direction of the magnetic field around the ferromagnetic resonance edge, which is indicative of the ISHE effect.

The researchers next measured the voltage dependence on the angle of the out-of-plane magnetic field. This revealed that a spin current is injected into the Si layer and that it precesses around an axis parallel to the applied magnetic field (see figure). Using the Landau-Lifshitz-Gilbert equation, Ando and Saitoh were able to demonstrate dynamical spin injection in *p*-type silicon at room temperature and unambiguously extract the ISHE contribution from the silicon layer. This technique can be used to explore the spin Hall effect in silicon with different dopants and doping levels, according to the researchers.

Moreover, the researchers said that their technique can be applied to understand other materials with weak spin-orbit interactions. This makes it particularly useful for spin-current

detection in semiconducting systems and opens many new areas for spintronics research.

Steven Spurgeon

Particle-free silver ink prints small, high-performance electronics

University of Illinois at Urbana-Champaign (UIUC) materials scientists have developed a reactive silver ink for printing high-performance electronics on ubiquitous, low-cost materials such as flexible plastic, paper, or

fabric substrates. Jennifer Lewis, the Hans Thurnauer Professor of Materials Science and Engineering and director of the Frederick Seitz Materials Research Laboratory, and graduate student S. Brett Walker described the new ink in the January 25 issue of the *Journal of the American Chemical Society* (DOI: 10.1021/ja209267c; p. 1419).

Most conductive inks rely on tiny metal particles suspended in a solvent.

The new ink is formed from a transparent solution of silver acetate and ammonia through a modified Tollens' process. The silver remains dissolved in the solution until it is printed, and the liquid evaporates, yielding conductive features. The ink is composed of 22 wt% silver, comparable to other silver-precursor-based inks.

"It dries and reacts quickly, which allows us to immediately deposit silver as

