

## FORMATION OF SMECTITE CRYSTALS AT HIGH PRESSURES AND TEMPERATURES

HIROHISA YAMADA, HIROMOTO NAKAZAWA, AND HIDEO HASHIZUME

National Institute for Research in Inorganic Materials  
Namiki 1, Tsukuba, Ibaraki 305, Japan

**Abstract**—Smectite single crystals of superior quality were synthesized at high pressures and temperatures using a modified belt type high pressure apparatus. Pressure–temperature conditions were established for smectite formation by quenching experiments in the pressure range from 2–5.5 GPa and temperatures of 700°–1000°C. Smectite crystals with extraordinary quality were formed beyond 3 GPa and 1000°C with coexisting phases of coesite, kyanite, jadeite, and in some cases with mica and glass. Smectite was confirmed from the XRD taken after intercalation of ethylene glycol. The smectite crystals were considered to be quenched crystals metastably from the hydrous silicate melts formed at high pressures and temperatures.

**Key Words**—High pressure, High temperature, Smectite, Synthesis.

### INTRODUCTION

Smectite naturally occurring due to weathering, diagenesis and hydrothermal alteration, is considered to be formed at low pressure and temperatures less than about 200°C (Pytte and Reynolds 1989; Tucker 1991). Syntheses of smectite were performed at low pressure and low temperature (Güven 1988). All such smectites were an aggregate of fine and poorly ordered particles of smectite. No single crystal of smectite has been either synthesized in laboratory or found in nature.

Recently smectite crystals with high structural ordering and large dimensions were synthesized at an extraordinary high-pressure and high-temperature condition (e.g., 5.5 GPa at 1500°C) (Nakazawa *et al* 1992). The magnitude of this pressure and temperature are comparable to those of the earth's mantle and to those of the syntheses of artificial diamond. The smectite crystals were formed with coexisting high-pressure minerals (coesite, kyanite and jadeite). The 001 diffraction peaks of the smectite crystals, 12.3 Å, were very sharp and expanded to 16.7 Å after ethylene glycolation. The full width at half maximum intensity of the 001 reflection was about 0.35° and was less than 1/3 of those of common smectites. A transmission electron micrograph showed the size of the smectite crystal to be more than a few 10 μm. The selected electron diffraction patterns indicated that the large smectite crystals were single crystals.

In the present paper, the formation conditions of the smectite crystals are investigated at very high-pressures and high-temperatures by using a modified belt type high-pressure and high-temperature apparatus. The pressure and temperature ranges of smectite formation were also determined.

### EXPERIMENTAL

Two different starting materials were used for the high-pressure and high-temperature experiments. One of them was the same as the glass used in the previous study (Nakazawa *et al* 1992). A mixture of Na<sub>2</sub>CO<sub>3</sub>, MgO, Al<sub>2</sub>O<sub>3</sub> and SiO<sub>2</sub> in the stoichiometric composition of a dehydrated Na-montmorillonite was fused using an infrared focusing-image furnace and quenched into water. The chemical composition of the quenched glass was determined to be Na<sub>0.87</sub>Mg<sub>0.67</sub>Al<sub>3.21</sub>Si<sub>8.08</sub>O<sub>22</sub> by an electron microprobe analyzer (SHIMADZU, EPMA SM-7). The composition was slightly richer in Na<sub>2</sub>O and SiO<sub>2</sub> compared with the ideal Na-montmorillonite. The glass was pulverized in an alumina mortar with water and was fractionated to be <20 μm by hydraulic elutriation. The other one was a synthetic Na-montmorillonite prepared by hydrothermal treatment (Yamada *et al* 1991). A mixture of glass of the same composition as above and distilled water in the ratio of 1:1 by weight was sealed in a Au-tube, and then treated at 100 MPa, 325°C for 10 days in a rapid quench type hydrothermal apparatus (Yamada *et al* 1988).

High-pressure and high-temperature experiments were carried out with a modified belt type high-pressure apparatus with a bore diameter of 32 mm (Yamaoka *et al* 1992). The generated pressure was calibrated at room temperature against the known pressure-induced phase transition of Bi, Tl and Ba. Sample temperature was monitored by the relation between the input electric power and the temperature, which had been calibrated in advance by using Pt6%Rh–Pt30%Rh thermocouple. It took about 10 minutes for the sample to reach a desired temperature after input power reached the desired value be-

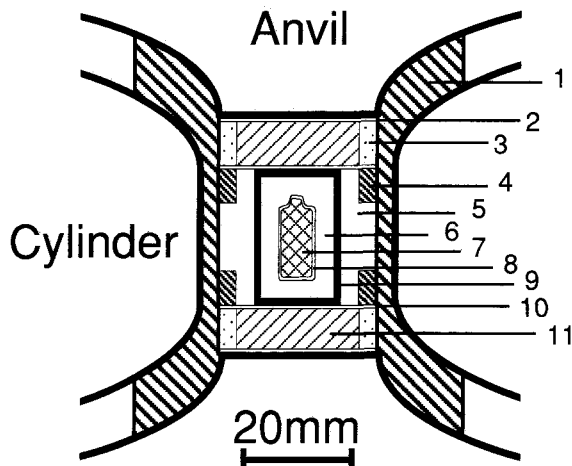

Figure 1. Sample assembly for high-pressure and high-temperature experiment. 1: pyrophyllite gasket, 2: stainless steel plate, 3: current ring, 4: steel ring, 5, 6: pressure medium, NaCl-ZrO<sub>2</sub> (10 wt%), 7: sample, 8: platinum capsule, 9: graphite heater, 10: Mo plate, 11: ZrO<sub>2</sub> disk.

cause the sample was surrounded by a large volume of pressure generating media.

The sample assembly is schematically shown in Figure 1. The starting material was sealed in platinum capsule (6.0 mm in outer diameter, 0.25 in thickness and about 10 mm in length) with distilled water, where the water/solid ratio was 1/3 by weight. After keeping the sample at desired pressure and temperature for a certain duration, the sample was quenched by shutting off the electric power supply. The pressure was then released slowly and the product was recovered at ambient conditions.

The run products were examined by an X-ray powder diffraction (XRD) method. A portion of run product was crushed and then mounted on a zero background quartz plate without compression to avoid the influence of preferred orientation. The XRD patterns were used for the identification of mineral products. Although smectite was found in the preliminary XRD patterns, it was confirmed by XRD patterns of ethylene glycolated samples which were prepared by orienting the run products of glass slides with water placing them in a container with ethylene glycol, and heating overnight in an oven at 60°C.

## RESULTS

### *Phases identified in the samples treated at very high-pressure and high-temperature*

Phases identified in the samples of the present experiments are summarized in Table 1 and shown in a P-T diagram (Figure 2). Above 3 GPa and 1000°C, smectite was formed with coexisting high-pressure minerals: coesite, kyanite, jadeite, and rarely mica. The

Table 1. Phases identified in high-pressure and high-temperature experiments.

P (GPa)	Temp (°C)	Time (min)	Starting materials <sup>1</sup>	Run product <sup>2</sup>
2	700	150	G	M, V, Qz, K, W(nd)
2	800	90	G	M, Qz, K, W(12)
2	900	45	G	low-S, M, Qz, K, W(8)
2	1000	30	G	low-S, Cor, Qz, K, G, W(8)
2	1100	1	G	low-S, Cor, G, W(8)
3	700	90	G	C, K, J, M, U1, W(14)
3	800	60	G	C, K, J, M, low-S, W(14)
3	900	45	G	C, K, M, low-S, W(12)
3	1000	30	G	Sm, C, K, G, W(8)
3	1100	30	G	Sm, C, K, G, W(9)
3	1200	20	G	Sm, C, K, G, W(nd)
4	800	120	G	C, K, J, U2, U3, W(14)
4	900	60	G	C, K, J, U2, U3, W(14)
4	1000	60	G	Sm, C, K, J, W(nd)
4	1200	30	G	Sm, C, K, G, W(nd)
4	1300	5	S	Sm, C, K, G, W(nd)
4	1400	1	S	Sm, C, K, M, G, W(nd)
5.5	800	120	S	C, K, J, CEn, Ch, U1, W(14)
5.5	900	60	S	C, K, J, CEn, Ch, U1, W(14)
5.5	1000	60	S	Sm, C, K, J, U1, W(14)
5.5	1200	30	S	Sm, C, K, J, W(14)
5.5	1400	30	S	Sm, C, K, J, W(14)
5.5	1500	50	G	Sm, C, K, J, M, W(nd)
5.5	1600	10	S	Sm, C, K, J, W(14)
5.5	1700	5	S	Sm, C, K, J, W(12)
5.5	1800	1	G	Sm, C, K, J, U1, W(nd)

<sup>1</sup> G: quenched glass, S: synthetic smectite at hydrothermal conditions.

<sup>2</sup> Sm: smectite crystal with high crystallinity, C: coesite, K: Kyanite, J: jadeite, CEn: clinoenstatite, Ch: chlorite, M: Mica (or illite), Qz: quartz, Low-S: low-temperature smectite with low crystallinity which is as same as that of natural smectite, V: vermiculite, Cor: corundum, G: quenched glass, U1: unidentified phase with a weak reflection at 4.0 Å, U2: unidentified phase with a very weak reflection at 3.6 Å, U3: unidentified phase with a very weak reflection at 4.6 Å, W: free water, the number in the parentheses indicates the value in pH. nd: not determined.

basal spacing of the smectite expanded from 12.3 Å to 16.7 Å after ethylene glycol treatment. The 001 reflection was very sharp, less than 1/3 of those of natural smectite (Brindley 1984), and was comparable to those of coexisting high-pressure minerals (Figures 3 and 4). The X-ray profile indicates that the formed smectite has dimensions comparable to typical three-dimensional crystals.

At 5.5 GPa and above 1000°C, the proportion of the smectite crystals in a run product increased with the increase in temperature. Above 1400°C, smectite crystals and coesite were dominant phases, and kyanite and jadeite were minor phases (Figure 3). They coexisted with free water (pH ~ 14). At 1000°C, the smectite was a minor phase and coexisted with a large amount of coesite and a small amount of kyanite and jadeite. Below 1000°C, no smectite crystal was formed. Mineral phases appeared were coesite, kyanite, jadeite, clino-

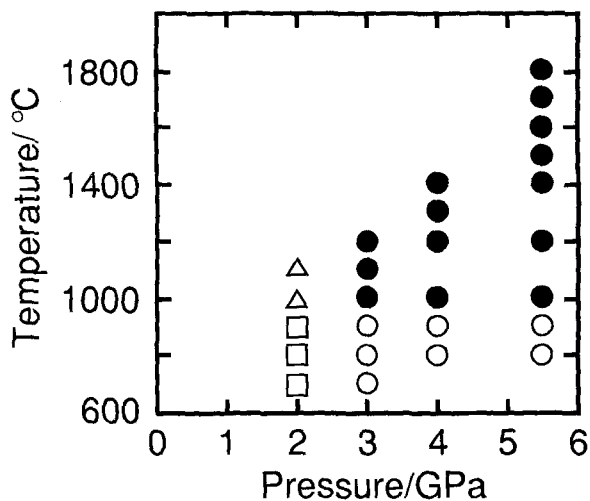

Figure 2. Assemblages observed in the high-pressure and high-temperature experiments. Solid circle: smectite + coesite + kyanite + jadeite + glass + mica + unidentified phase. Open circle: coesite + kyanite + jadeite + mica + clinopyroxene + chlorite + unidentified phases. Open triangle: low-temperature smectite + glass + corundum. Open square: Low-temperature smectite + quartz + mica + kyanite.

pyroxene, chlorite, an unknown phase having a diffraction peak at 3.66 Å and free water (pH ~ 14).

At 4 GPa and above 1000°C, the amount of smectite increased with the increase in temperature and coexisted with glass. Above 1200°C, the smectite crystals appeared dominant, coexisting with kyanite, coesite, glass, and free water (the pH was not measured because of small amount). At 1000°C, coesite was dominant and smectite, kyanite, jadeite, and free water were observed in small amounts. Below 1000°C, no smectite was formed and coesite was the main phase coexisting with kyanite, jadeite, an unknown phase having a diffraction peak at 3.66 Å, and free water (pH ~ 14).

At 3 GPa and above 1000°C, the same results as for 4 GPa and above 1000°C were observed for the amount of the smectite crystals and glass, but the pH of the coexisting water decreased to 8 ~ 9 (Figure 4).

At 2 GPa, the smectite was not formed in the entire range of temperature examined. Above 1000°C, the common smectite coexisted with corundum, glass and/or kyanite. Mineral phases observed at 700°C, 800°C and 900°C are listed in Table 1.

#### *Isothermal experiments at 5.5 GPa*

The phases obtained in the isostatic experiments at the pressure of 5.5 GPa are listed in Table 2 corresponding to every selected temperature and run duration. No systematic variations were observed in the phases appeared and in the contents of the smectite crystal, which was estimated semiquantitatively from the integrated intensity of 001 reflection. Because the thermal equilibrium of the sample space in the high-

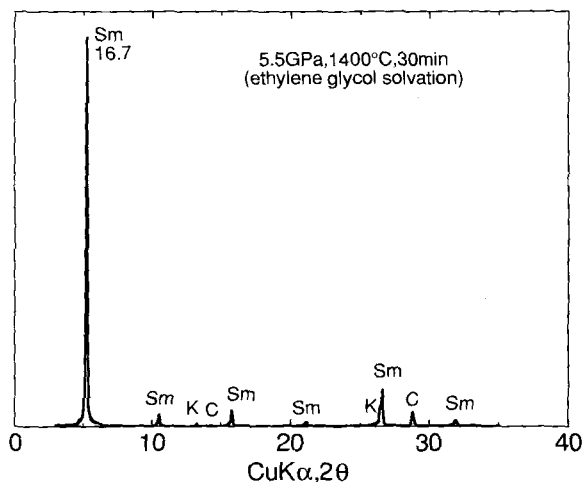
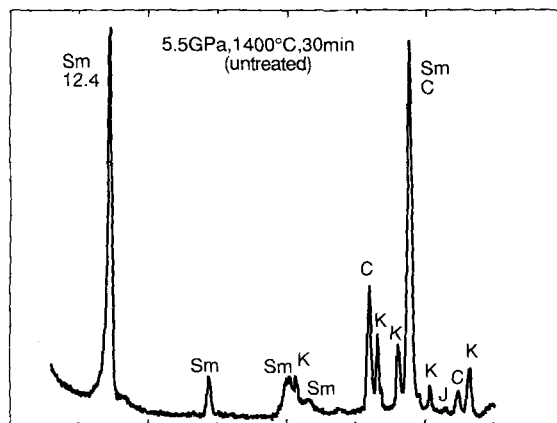

Figure 3. X-ray powder diffraction patterns of the high-pressure and high-temperature product at 5.5 GPa and 1400°C for 30 min (top) before and (bottom) after ethylene glycol treatment. Sm: smectite crystal. C: coesite. K: kyanite. J: jadeite. The number indicates the d-spacing of peak in Å.

pressure experiments, to Dr. S. Varanasi, N.I.R.I.M., for his correction of the manuscript, and Dr. Y. Tsumi, Kyoto University, Drs. T. Fujita and S. Shimomura, N.I.R.I.M. for their useful discussion.

#### DISCUSSION

Some melting experiments have been conducted with silicates of similar composition to the present material at high-pressure and high-temperature under water-saturated condition (Robertson and Wyllie 1971; Kushiro 1972; Green 1973; Wyllie 1979). Those studies focused on magma genesis. They indicated that the melting temperature of such silicates was almost 1000°C in the pressure range presently applied. Although the determination of liquidus temperature was not the purpose of the present study, the presence of glass in the run products at 2 to 4 GPa and above 1000°C suggested that the liquidus temperature of the present material

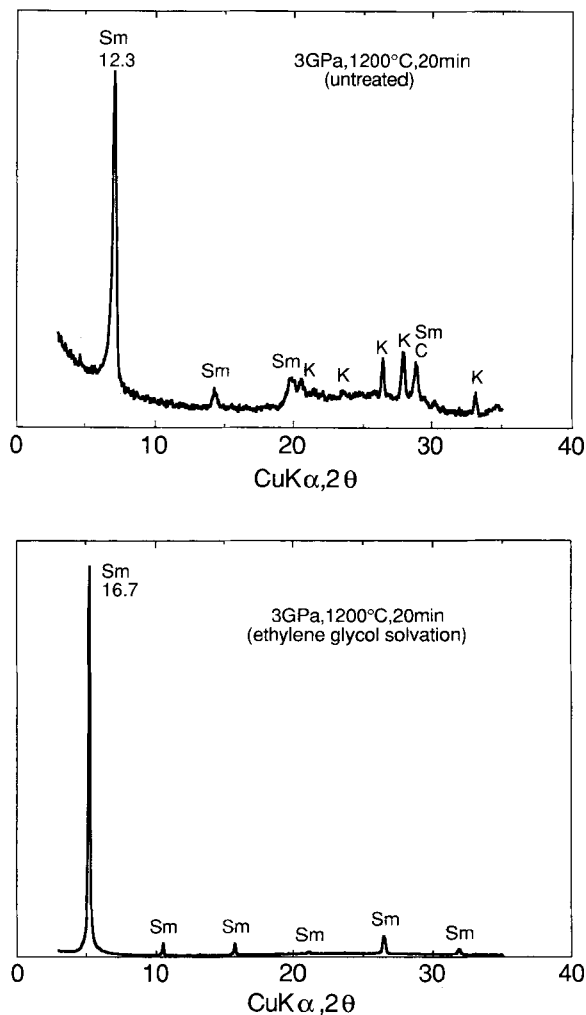

Figure 4. X-ray powder diffraction patterns of the high-pressure and high-temperature product at 3 GPa and 1200°C for 20 min (top) before and (bottom) after ethylene glycol treatment. Sm: smectite crystal. C: coesite. K: kyanite. J: jadeite. The number indicates the d-spacing of peak in Å. Broad peak from quenched glass was observed at around 20–30 degree in  $2\theta$  before ethylene glycol treatment.

is also about 1000°C and is comparable to that of the previous studies.

As described above, the samples were treated at high-pressures and temperatures for the desired durations, and were quenched by shutting off electric power supply. Because the smectite crystals were found only in those experiments treated above 1000°C (Figure 2), they are probably not formed in an equilibrium state but during the quenching process from the hydrous melt (Burnham 1974, 1975). This interpretation is consistent with the observations that the formation of the smectite crystals at the lower limits of pressure and temperature and the yield was dependent only on the temperature from which the sample was quenched, and

Table 2. Phases identified in the isothermal experiments.

P (GPa)	Temp (°C)	Time (min)	Starting materials <sup>1</sup>	Run product <sup>2</sup>
5.5	1250	1	G	Sm, C, K, J, W(nd)
5.5	1250	10	G	Sm, C, K, J, W(14)
5.5	1250	20	G	Sm, C, K, J, W(nd)
5.5	1250	30	G	Sm, C, K, J, W(nd)
5.5	1250	100	G	Sm, C, K, J, W(nd)
5.5	1500	1	G	Sm, C, K, J, W(nd)
5.5	1500	10	G	Sm, C, K, J, W(nd)
5.5	1500	20	G	Sm, C, K, J, W(nd)
5.5	1500	30	G	Sm, C, K, J, W(nd)
5.5	1500	100	G	Sm, C, K, J, W(14)

<sup>1</sup> G: quenched glass.

<sup>2</sup> Sm: smectite crystal with high crystallinity, C: coesite, K: Kyanite, J: jadeite, W: free water, the number in the parentheses indicates the value in pH, nd: not determined.

independent of the run duration at that particular temperature.

In previous melting experiments, some phyllosilicates, mica and chlorite, were also formed as quenched crystals, but not smectite (Kushiro 1972; Green 1973). This is probably due to the difference in the chemical compositions of the starting materials and thus the hydrous melts. The present one is richer in silica compared with those previously examined. Furthermore any slight difference in quenching process, which is affected largely by the design of the high pressure apparatus used, is another reason for smectite formation, because the kinetics of the smectite formation are dependent considerably on the quenching process.

As is shown in Figure 2, there is a lower pressure limit for the formation of smectite crystals. The reason why more than 3 GPa is necessary cannot be easily explained. But some previous reports on the viscosities of melts of silicates and natural igneous rocks at high pressures and high temperatures suggest the possible reason. A remarkable decrease in the viscosity of the melt was observed around 1 GPa (Kushiro 1976; Kushiro *et al* 1976) and the presence of water in the melt enhanced the viscosity drop (Kushiro *et al* 1976). This phenomenon was first speculated as due to a structure change of the melt: the coordination polyhedra of Al in the melt changes partially from tetrahedral to octahedral at that pressure. But recent studies found in the quenched glass of  $K_2Si_4O_9$ , the existence of five-fold coordination of silicon ( $Si^V$ ) (Stebbins and McMillan 1989; Stebbins 1991) and an increase of  $Si^V$  with pressure (Xue *et al* 1991). The decrease of viscosity of silicate melts with pressure is explained by the increase of  $Si^V$  (Kanzaki 1992). Although the chemical composition of the melt presently examined is not same as those described above, there are no large differences in the melt structure of similar silicates, and thus pressure dependence of viscosity can be considered. The lower limit of pressure for the formation of the smectite crystals corresponds probably to the dras-

tic changes of viscosity and structure of silicate melt at around 2 GPa. If this interpretation is completely true, it is reasonable that the formation of the smectite crystals as metastably quenched crystals may be affected strongly by the different melt structures above and below 3 GPa.

#### ACKNOWLEDGMENTS

The authors are indebted to Drs. S. Yamaoka and M. Akaishi, N.I.R.I.M., for their cooperation in high-pressure experiments, to Dr. S. Varanasi, N.I.R.I.M., for his correction of the manuscript, and Dr. Y. Tatsu-mi, Kyoto University, Drs. T. Fujita and S. Shimomura, N.I.R.I.M. for their useful discussion.

#### REFERENCES

- Brindley, G. W. 1984. Order-disorder in clay mineral structure. In *Crystal Structures of Clay Minerals and their X-ray Identification*. G. W. Brindley and G. Brown, eds. London: Mineralogical Society, 125–195.
- Burhnam, C. W. 1974.  $\text{NaAlSi}_3\text{O}_8\text{-H}_2\text{O}$  solutions; a thermodynamic model for hydrous magmas. *Bull. Mineral. Crystallogr.* **97**: 223–230.
- Burhnam, C. W. 1975. Water and magmas; a mixing model. *Geochim. Cosmochim. Acta* **39**: 1077–1084.
- Green, D. H. 1973. Experimental melting studies on a model upper mantle composition at high pressure under water-saturated and water-undersaturated conditions. *Earth Planet. Sci. Letters* **19**: 37–53.
- Güven, N. 1988. Smectite. In *Hydrous Phyllosilicate (Exclusive of Micas)*. Reviews in Mineralogy 19. S. W. Bailey ed. Washington, D.C.: Mineralogical Society of America, 497–559.
- Kanzaki, M. 1992. Pressure-induced structural changes in silicate glass (melt). *J. Mineral. Soc. Japan*. **21**: 149–160. (in Japanese with English abstract).
- Kushiro, I. 1972. Effect of water on the composition of magmas formed at high pressures. *J. Petrol.* **13**: 311–334.
- Kushiro, I. 1976. Changes in viscosity and structure of melt of  $\text{NaAlSi}_3\text{O}_8$  composition at high pressures. *J. Geophys. Res.* **81**: 6347–6350.
- Kushiro, I., H. S. Yoder, and B. O. Mysen. 1976. Viscosities of basalt and andesite melts at high pressures. *J. Geophys. Res.* **81**: 6351–6356.
- Nakazawa, H., H. Yamada, and T. Fujita. 1992. Crystal synthesis of smectite applying very high pressure and temperature. *Applied Clay Science* **6**: 395–401.
- Pytte, A. M., and R. C. Reynolds. 1989. The thermal transformation of smectite to illite. In *Thermal History of Sedimentary Basins*. N. D. Naeser and T. H. McCulloh, eds. New York: Springer-Verlag.
- Robertson, J. R., and P. J. Wyllie. 1971. Rock-water systems, with special reference to the water-deficient region. *Amer. J. Sci.* **271**: 252–277.
- Stebbins, J. F. 1991. NMR evidence for five-coordinated silicon in a silicate glass at atmospheric pressure. *Nature* **351**: 638–639.
- Stebbins, J. F., and P. F. McMillan. 1989. Five- and six-coordinated Si in  $\text{K}_2\text{Si}_4\text{O}_9$  at 1.9GPa and 1200°C. *Am. Mineral.* **74**: 965–968.
- Tucker, M. E. 1991. *Sedimentary Petrology, 2nd Edition*. London: Blackwell Scientific Publications.
- Wyllie, P. 1979. Magmas and volatile components. *Am. Mineral.* **64**: 469–500.
- Xue, X., J. F. Stebbins, M. Kanzaki, P. F. McMillan, and B. Poe. 1991. Pressure-induced silicon coordination and tetrahedral structural changes in alkali oxides-silica melts up to 12GPa: NMR, Raman, and Infrared spectroscopy. *Am. Mineral.* **76**: 8–26.
- Yamada, H., T. Fujita, and H. Nakazawa. 1988. Design and calibration of a rapid quench hydrothermal apparatus. *J. Ceramic Soc. Japan* **96**: 1041–1044.
- Yamada, H., H. Nakazawa, K. Yoshioka, and T. Fujita. 1991. Smectites in the montmorillonite-beidellite series. *Clay Miner.* **26**: 359–369.
- Yamaoka, S., M. Akaishi, H. Kanda, T. Osawa, T. Taniguchi, H. Sei, and O. Fukunaga. 1992. Development of belt type high pressure apparatus for material synthesis at 8GPa. *J. High Pressure Inst. Japan* **30**: 249–258 (in Japanese with English abstract).

(Received 26 January 1994; accepted 4 June 1994; Ms. 2459)