

THE AËRONAUTICAL JOURNAL.

The
Organ of the
Royal Aëronautical Society

—
Entered at
Stationers'
Hall.



Edited for
the Council of the
Royal Aëronautical Society
by
W. Barnard Faraday,
LL.B., F.S.S.

Price to Non-Members and Non-Subscribers, 2s. 9d. post free.

No. 91.

JULY, 1918.

Vol. XXII.

VICKERS LIMITED.

Contractors to H.M. GOVERNMENT.

Aviation Department,
Imperial Court, Basil Street,
KNIGHTSBRIDGE, S.W.3.

Telephone
KENSINGTON 6520 (2 lines).



Telegraphic Address:
"VICKERFYTA-KNIGHTS, LONDON."



"THE NAVY THAT FLIES."
"NIGHT-FLYING SCOUTS LEAVING THE MOTHER SHIP."

WAKEFIELD



Castrol
'R' MOTOR OIL.
 (Racing)
The One Oil for all Aero Engines.
Immediate Delivery to Rails Guaranteed.

C. C. WAKEFIELD & CO., LTD.
 (Sir Charles Wakefield, Bt., Governing Director)
 Wakefield House, Cheapside, London, E.C.2.

C.D.C.

MANUFACTURERS OF LUBRICANTS FOR ALL CLASSES OF POWER PLANT AND MACHINERY.

CRADOCK'S STEEL WIRE STRANDS & CABLES FOR RIGGING AIRCRAFT.

(AS THE QUESTION OF SOUND RIGGING IS ONE OF SUCH VITAL IMPORTANCE, THE BEST ONLY SHOULD BE USED.)

Since the Advent of Flying, this Company—

WHO HAVE MANUFACTURED STEEL WIRE ROPES FOR OVER 60 YEARS,
 have made a special study of this class of work, and have for some years now supplied

SPECIAL FLEXIBLE STRANDS AND CABLES FOR AVIATION

constructed of 7, 19, 37, 49, 133, and 259 Galvanized or Plated Steel Wires of the greatest tensile strain possible compatible with the requisite ductility and toughness, and ranging from

BREAKING STRAINS of from 375 to 18230 Lbs

THERE IS NOTHING BETTER OBTAINABLE.

GEO. CRADOCK & Co. Ltd., WAKEFIELD,

**CONTRACTORS TO THE
ADMIRALTY
AND THE WAR OFFICE.**

CABLES SUPPLIED TO R.A.F. SPECIFICATION.

DESCRIPTIVE BOOKLET WITH FULL DETAILS ON APPLICATION.

SUNBEAM-COATALEN AIRCRAFT MOTORS



The **SUNBEAM MOTOR
CAR CO., LTD.,
WOLVERHAMPTON.**

CONTRACTORS
TO H.M.
GOVERNMENT.



**AEROPLANES
AND
PARTS.**

A. V. ROE & Co., LTD.,

**NEWTON HEATH,
MANCHESTER.**

Telephones: City 8530 & 8531.
Telegrams: Triplane.

SOUTHAMPTON.

Telephone: Hamble 18.
Telegrams: Roe, Hamble.

Code: A.B.C., 5th Edition.

**166, PICCADILLY,
LONDON, W.1.**

Telephone: Gerrard 3186.
Telegrams: Senalpirt, Phone.



FOR four full years the entire Siddeley-Deasy organisation and resources have been devoted to the service of the nation. In that period—and in that service—a position of absolute supremacy has been achieved.

The SIDDELEY-DEASY MOTOR-CAR Co., Ltd., COVENTRY.

Contractors to H.M. Air Ministry; Designers and Constructors of Aero Engines, Aeroplanes and Luxurious Motor Carriages.

ESTABLISHED 1912.

Contractors to H.M. Air Ministry.

THE

SUPERMARINE

AVIATION WORKS, Ltd.

Designers and
Constructors of

FLYING BOATS

Telephone :
WOOLSTON 37.

Telegrams :
"SUPERMARIN."



Offices, Works,
Flying Waters,

SOUTHAMPTON, ENG.

H. SCOTT-PAINE, Director and General Manager.

TOLEDO



BRAND

AIRCRAFT STEELS.

All Grades : by Electric, Siemens, and Crucible Processes
Heat-treated, Forged or Rolled,
to Airboard & Engineering Standard Specifications.

J. NO. HY. ANDREW & Co., Ltd.,

Toledo Steel Works,

SHEFFIELD,

ENGLAND.

London Offices -

City : 118, Cannon St., E.C.4.

Westminster : 17, Victoria St., S.W.1.

Telegraphic & Cable Address : "ANDREW, SHEFFIELD."

The Pioneers

Of the Plywood industry were Venesta Ltd.; they held the premier position then because there were no competitors. Now, in the face of increasing competition from almost every country in the world, they hold it still—indisputably.

VENESTA PLYWOOD

It is in constant demand by the British and Allied Governments, the largest Shipbuilding and Railway Companies, Aeroplane & Motor Car Builders, etc. It is waterproof, unshrinkable, and practically indestructible, and these qualities, together with its smooth, clean surface, make it the finest material in the world for panelling of every description.

Write for Booklet and Samples.

Venesta Ltd.
LONDON

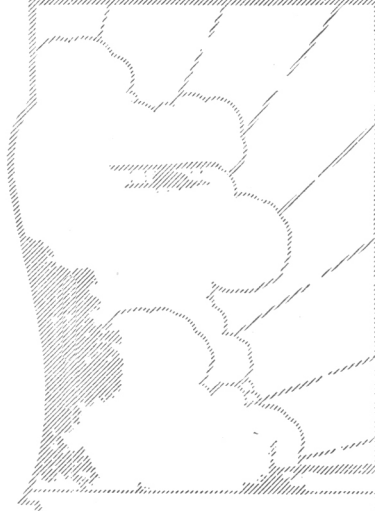

CELLON

LIMITED.

CONTRACTORS TO THE ADMIRALTY, WAR OFFICE,
AUSTRALIAN GOVERNMENT, UNION OF S. AFRICA.

AEROPLANE DOPE
and **VARNISH**
MANUFACTURERS.

HEAD OFFICE: BROAD STREET HOUSE, NEW BROAD STREET,
TELEGRAMS: LONDON, E.C. TELEPHONE: LONDON WALL: 5359.
AJAWB. AVE. LONDON. WORKS: STIRLING CHEMICAL WORKS, STRATFORD, LONDON, E.

G.H.W. 6

E. BENNETT & SON, L^{TD.}

EVERY APPLIANCE FOR

HEATING

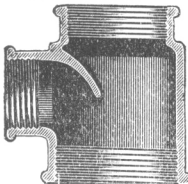
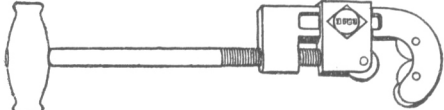
AEROPLANE HANGARS.
AIRCRAFT FACTORIES, ETC.

'PHONE OR WRITE FOR CATALOGUES.

PHONE: 8062-4 AVENUE. 45/51, LEMAN STREET, E.1.
GRAMS: SPRUCENESS.
ALD. LONDON.

NAPIER

The proved Best Car.

British Built

AERO ENGINES

The Chief requirement in the air is

RELIABILITY

Napier Aero Engines, like the famous Napier 6-Cylinder Car (the original and proved best), are manufactured by a firm with

**Over a Century's
Engineering Experience
Behind It.**

D. NAPIER & SON, LTD.,

WORKS: ACTON, LONDON, W.

14, NEW BURLINGTON STREET, LONDON, W.

AERO ENGINES



**Aerodrome and Auxiliary Works:
BROOKLANDS.**

MARTINSYDE LTD.

**Head Office and Works
WOKING
Surrey**

THE BRITISH AND COLONIAL AEROPLANE Co., Ltd.,

FILTON, BRISTOL.

CONSTRUCTORS OF —

The "Bristol" Aeroplanes

CONTRACTORS TO THE
ROYAL AIR FORCE.

TELEGRAMS:
"AVIATION, FILTON."



TELEPHONES:
3906 BRISTOL.

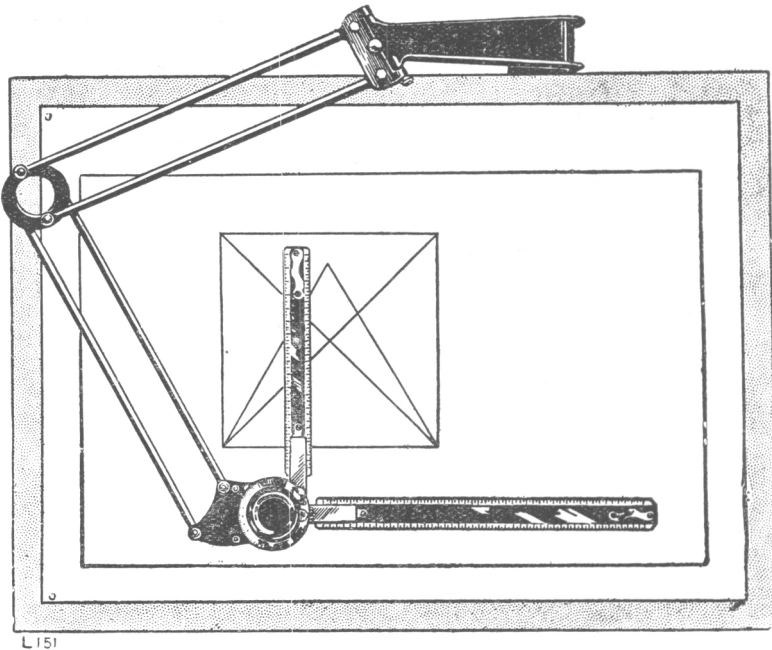

UNIVERSAL DRAFTING MACHINES.

When time presses, the Universal Drafting Machine proves its greatest worth. It is a remarkable aid to clearness of thought, accuracy and rapidity of expression. It considerably increases the efficiency of a draftsman owing to its accuracy and easy sensitive motion.

All our draftsmen use them; we could not afford to have our drawings made by the old method.

May we send YOU particulars?

ALFRED HERBERT LTD. COVENTRY.

TELEPHONE:—
OFFICE ... 912 REGENT.
WORKS ... 4762 KENSINGTON.
... 281-2-3 WEMBLEY.

TELEGRAMS:—
"SOCIABLE, PHONE, LONDON."

HOOPER & CO. LTD.

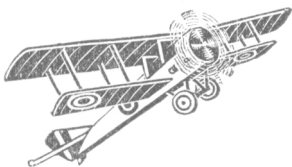

AEROPLANE BUILDERS
TO H.M. AIR COUNCIL.



BY ROYAL WARRANT.



BY ROYAL WARRANT.



BY ROYAL WARRANT.

**MOTOR BODY-BUILDERS
AND COACHBUILDERS**

BY APPOINTMENT TO

**H.M. THE KING H.M. THE QUEEN
H.M. QUEEN ALEXANDRA**

**54, St. James's Street,
PICCADILLY, LONDON, S.W.1**

JAMES W. SOUTHERN & SON L^{TD}, MANCHESTER



If you want the best

ASH

please let us know.
We have got it.



Telegrams:
LIGNUM
Manchester

Telephones:
253 } Central
4600 }
3740 City
68 Trafford Pk.

TRADE **J. RICHARDS. P.M.** MARK.
REGISTERED.

J. H. RICHARDS & CO. LTD.

CATO STREET NORTH
BIRMINGHAM

Telegrams "WESTMINSTER BIRMINGHAM."
Phone EAST 800

J. H. RICHARDS & CO. LIMITED. J. RICHARDS. P.M. BIRMINGHAM.



— AERO. ENGINE CRANK-SHAFT AND BEARINGS. —

J. H. RICHARDS & CO. LIMITED. J. RICHARDS. P.M. BIRMINGHAM.

ENGINEERS & MANUFACTURERS OF
AERO & MECHANICAL TRANSPORT
ENGINE PARTS

CONN RODS · CRANK SHAFTS · ETC

Conn Rod and Main Chair Bearings,
with Steel, Phosphor-Bronze, or
Gun Metal Shells, White-Metal lined.

also
Solid White Metal Die cast
under Pressure at low temperatures.
ACCURACY GUARANTEED.

SOLE MAKERS OF J. RICHARDS' "PLASTIC METAL"
FOR LINING ALL KINDS OF BEARINGS.

**Woodside Engineering Company, Limited,
Possilpark, Glasgow.**

AEROPLANE TIERODS

. IN .

STREAMLINE & ROUND SECTIONS

COMPLETE WITH

:: UNIVERSAL OR FORK JOINTS ::

LARGE STOCKS.

PROMPT DELIVERY.

WORKS 1495 DOUGLAS (2 Lines).

OFFICE: 3456 CENTRAL (3 Lines).

(Private Branch Exchange).

TELEGRAMS: "FUSELAGE," GLASGOW.

Registered Office:

50, WELLINGTON STREET

GLASGOW.

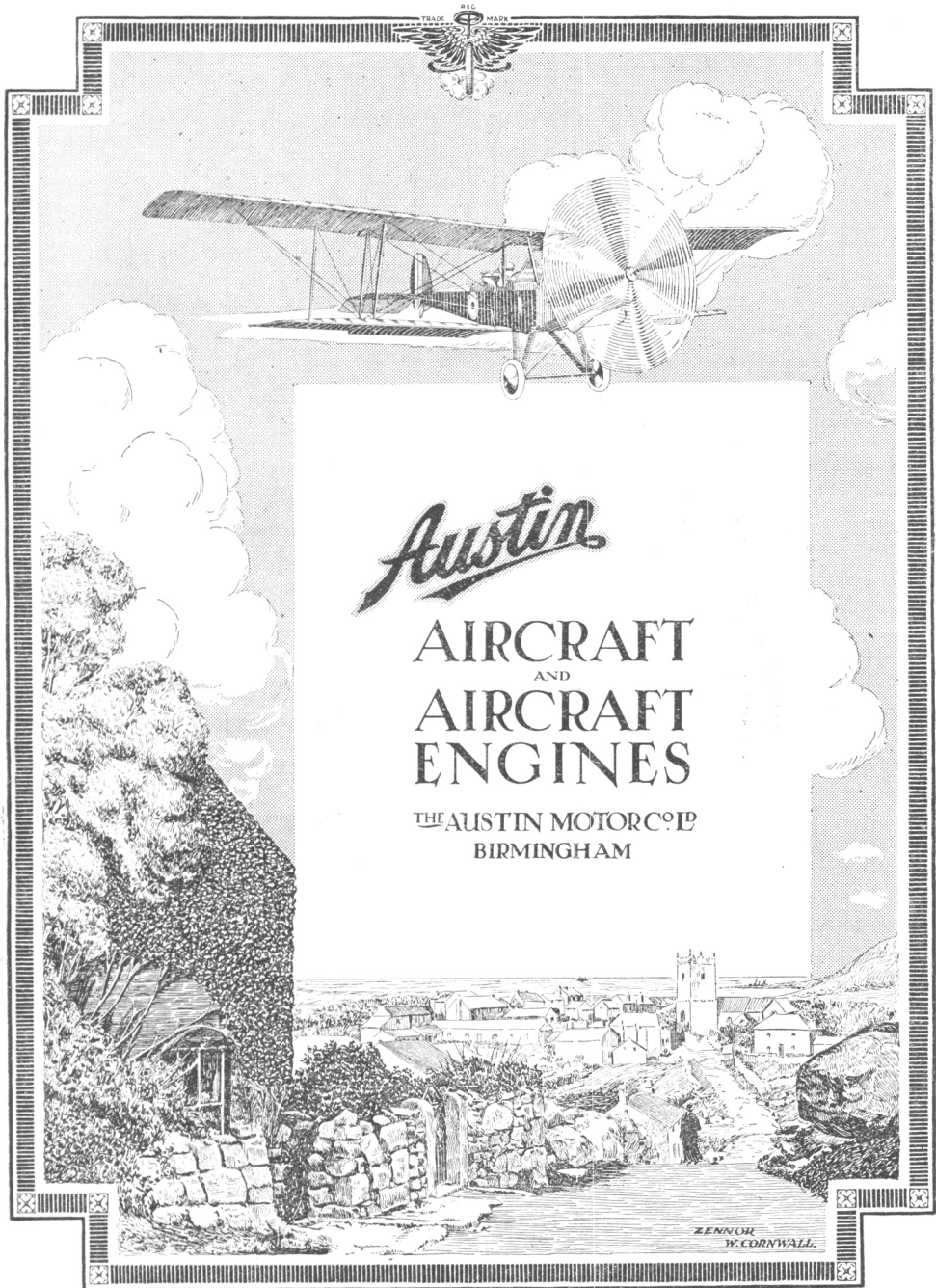

The illustration is framed by a decorative border with a repeating pattern. At the top center, a winged figure with a caduceus-like staff is labeled 'TRADE MARK'. Below this, a biplane is shown in flight, emitting a large, stylized cloud of smoke or exhaust. The central text is set within a white rectangular area. The word 'Austin' is written in a large, flowing script. Below it, 'AIRCRAFT AND AIRCRAFT ENGINES' is printed in a bold, serif font. Underneath, 'THE AUSTIN MOTOR CO. LTD.' and 'BIRMINGHAM' are printed in a smaller, all-caps serif font. The bottom portion of the illustration depicts a stone-walled village with a church spire, a stone bridge over a stream, and a road leading into the distance. The artist's signature 'ZENNOR W. CORNWALL' is located in the bottom right corner of the illustration.

TRADE MARK

Austin

AIRCRAFT
AND
AIRCRAFT
ENGINES

THE AUSTIN MOTOR CO. LTD.
BIRMINGHAM

ZENNOR
W. CORNWALL

AERATORS, Limited.

PRANA WORKS, EDMONTON, LONDON, N.18.

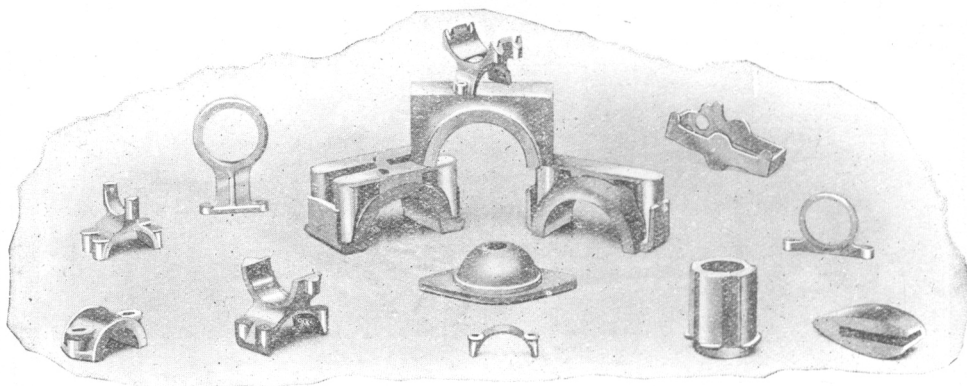

ALUMINIUM DIE CASTINGS for ALL PURPOSES.

Speciality—

ALUMINIUM CASTINGS for AERO ENGINES,
FIELD TELEPHONES, Etc., Etc.

WE MAKE TO ORDER—

ALLOYS

Involving the use of the following:

ALUMINIUM
ANTIMONY
BISMUTH
BORON
BERYLLIUM
CHROMIUM

COBALT
CADMIUM
COPPER
IRON
LEAD
MAGNESIUM

MANGANESE
MOLYBDENUM
NICKEL
SILICON
TIN
TITANIUM

TUNGSTEN
TANTALUM
URANIUM
VANADIUM
ZINC
ZIRCONIUM

METALS.

MINERALS.

THERMIT.

THE BRITISH THERMIT COMPANY, Limited,
49 TO 55, THE ALBANY,
LIVERPOOL.

Telegrams : "Thermetal, Liverpool."

Works : GARSTON.

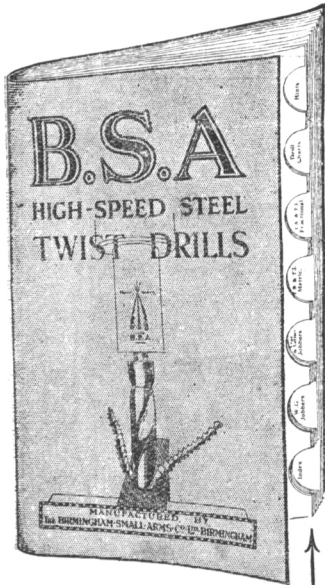

NOTE THE CUT-OUT INDEX FOR EASY REFERENCE.

Selling Agents for England—

BURTON, GRIFFITHS & Co., Ltd., 1, Ludgate Square London, Ludgate Hill, E.C.4.
Also at Birmingham, Manchester, and Glasgow.

Now Ready! Latest List of B.S.A. Twist Drills.

THE latest catalogue of B.S.A. High-Speed Twist Drills is a book of reference which should be found in every machine shop. It illustrates and describes a complete range of drills of every type and size to meet all requirements, and also contains some valuable information and hints on the use and care of twist drills. The cut-out index enables any part of the list to be easily and quickly found. Everyone interested in twist drills should send at once for a copy.

B.S.A. High-Speed Twist Drills are made with the well-known B.S.A. material, workmanship and finish. Thousands of them are daily employed in the manufacture of B.S.A. Productions, and every drill bearing the B.S.A. name is guaranteed to be of identically the same high quality as those used in the B.S.A. Works.

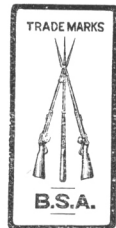

PURE METALS AND ALLOYS
FOR USE IN
AIRCRAFT CONSTRUCTION.



EXPERT IN WELDING
REPAIRS
OF ALL KINDS.

THERMIT, LTD.

(Proprietors: NOBEL'S EXPLOSIVES CO., LTD., GLASGOW.)

OWNERS OF THE ALUMINO-THERMIC PROCESS PATENTS.

(ESTABLISHED 1904).

ALLOYS MADE TO ANY SPECIFICATION.

675, COMMERCIAL ROAD, LONDON, E.14.



We are the original firm, and have no connection with any other concern which has seen fit to adopt a title somewhat similar to our own.

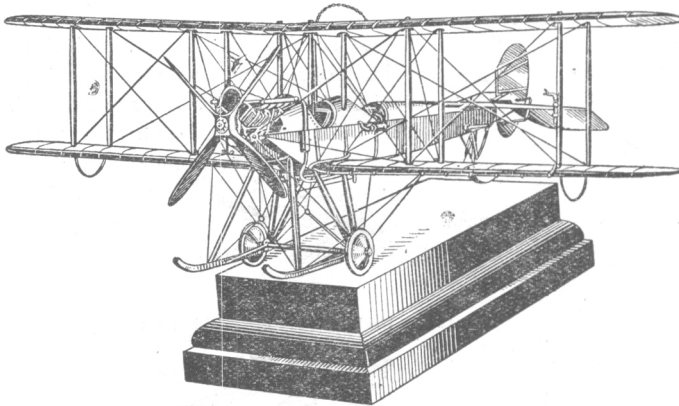

Aeroplane Models

THE Silver Model of an Aeroplane illustrated shows how technical knowledge and skilled workmanship are allied in the models produced by the Goldsmiths and Silversmiths Company.

Infinite care is taken to ensure every detail being accurate and of proper proportions, and to reproduce an exact replica of the original.

Models can be prepared from the original or from a photograph. Estimates and designs will be submitted free upon application.

The Goldsmiths and Silversmiths Company have no other establishments in Regent Street, Oxford Street, or anywhere else in London, and no branches in the Provinces or Abroad.

THE
GOLDSMITHS & SILVERSMITHS
COMPANY LTD. with which is incorporated The Goldsmiths' Alliance Ltd. Established 1751

112, Regent Street, London, W. I.



PALMER

Landing Wheels and Tyres.

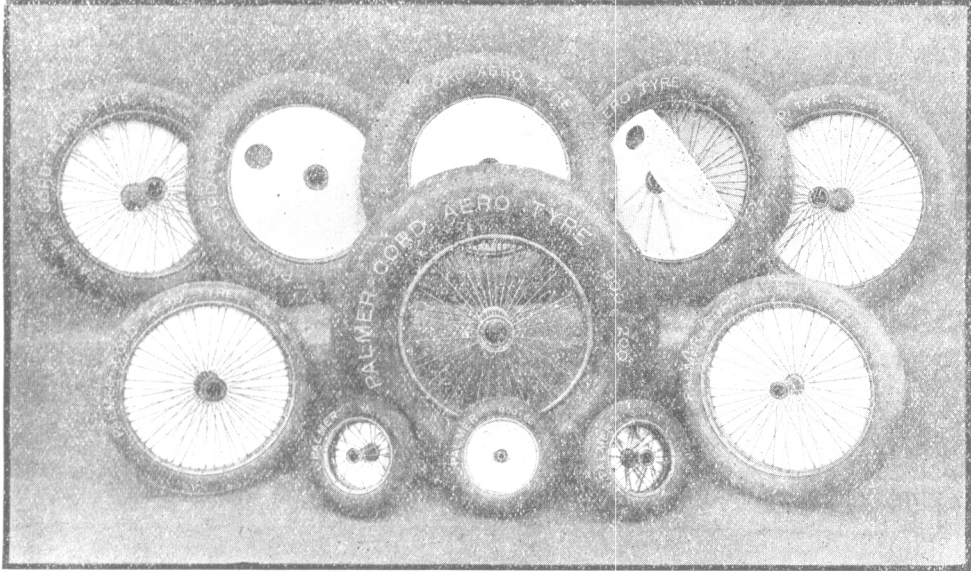

STANDARD SIZES:

Tyre Sizes.	Wheel No.	Hub.		Track Line.	Tyre Sizes.	Wheel No.	Hub.		Track Line.
		Length	Bore.				Length.	Bore.	
300 x 60	16	111.12	25.4	Central	750 x 125	33	150.	38.09	Central
	17	72.39	12.7	Central		77	178.	44.45	132/46
	21	89.	31.75	Central		92	185.	55.	135/50
450 x 60	30	160.	25.	Central	95	185.	55.	Central	
	34	150.	31.75	104/46	96	178.	38.89	132/46	
	111	150.	38.09	104/46	99	178.	38.89	132/46	
575 x 60	78	178.	44.45	132/46	112	150.	40.	Central	
	79	178.	44.45	Central	36†	185.	55.	135/50	
	100	178.	38.09	132/46	40†	185.	60.32	135/50	
650 x 65	101	178.	31.75	132/46	41†	185.	55.	Central	
	21	160.	28.	Central	82	185.	55.	135/50	
	34	150.	31.75	104/46	85	185.	55.	Central	
600 x 75	111	150.	38.09	104/46	106	185.	47.62	135/50	
	78	178.	44.45	132/46	108	185.	60.32	Central	
	79	178.	44.45	Central	205†	185.	65.4	Central	
700 x 75	100	178.	38.09	132/46	102	185.	55.	125/60	
	191	178.	31.75	132/46	201	185.	60.32	125/60	
	33	150.	38.09	Central	202	185.	60.32	Central	
700 x 100	77	178.	44.45	132/46	107	185.	55.	Central	
	92	185.	55.	135/50	108	185.	55.	125/60	
	95	185.	55.	Central	120	185.	66.67	125/60	
700 x 100	96	178.	55.	132/46	202	185.	60.32	Central	
	99	178.	38.89	132/46	208	185.	60.32	125/60	
	112	150.	40.	Central	52	185.	55.	116/69	
650 x 125	119	178.	55.	132/46	57	185.	55.	Centra	
					203	185.	60.32	116/69	
					204	185.	60.32	Central	

† Wheels Nos. 36, 40, 41 and 205 are of stronger type than the other wheels for 800 x 150 tyres.

THE PALMER TYRE LIMITED,

Contractors to the Admiralty, the War Office, and the Ministry of Munitions.
119, 121, 123, SHAFTESBURY AVENUE, LONDON, W.C.2.

Telegrams: "TYRICORD, WESTCENT, LONDON."

Telephone: GERRARD 1214 (Five Lines).

PARIS: 24, Boulevard de Villiers, Levallois-Perret.

HIDE GLUES

FOR
AIRSCREWS
AND
AIRCRAFT CONSTRUCTION.

APPROVED GLUES.

Manufacturers—
WM. OLDROYD & SONS, Ltd.,
9, MINCING LANE,
LONDON,

TELEPHONE
4978 Avenue.

E.C. 3.

WYCOMBE AIRCRAFT CONSTRUCTORS, Ltd.

Contractors to H.M. Government.

Telegrams :—Aircraft, High Wycombe.

Telephones :—High Wycombe 84.

(Stores—High Wycombe 120.)

HIGH WYCOMBE.

ORIGINAL
MANUFACTURERS OF
STREAMLINE

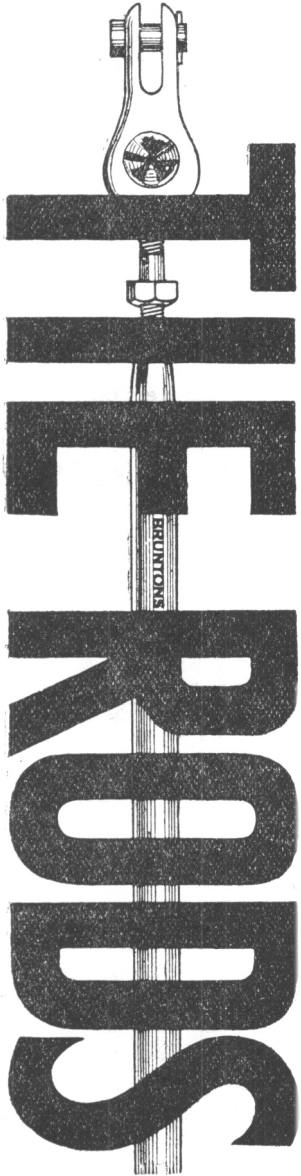

BRUNTONS
MUSSELBURGH
SCOTLAND. ———

ALUMINIUM CYLINDERS.

WATER AND AIR COOLED.

ALUMINIUM CASTINGS

Of every description for

AEROPLANE AND MOTOR ENGINES

IN SPECIAL STRONG LIGHT ALLOYS.

CAST IRON CYLINDERS

WATER AND AIR COOLED

FOR

AEROPLANE & MOTOR ENGINES.

WILLIAM MILLS, Ltd.,

Contractors to H.M. Government,

Grove Street,

Telegrams—"WILMIL, BIRMINGHAM."

Telephone—SMETHWICK 9.

BIRMINGHAM.

“Always at the Front”

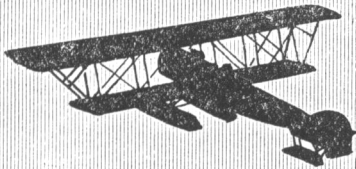

Contractors
to
H.M
GOVERNMENT

From the
earliest days
of Aviation, the
Blackburn firm
have been

PIONEERS

in design and construction.

To-day Blackburn
machines are

“Always at the
Front.”

Blackburn AIRCRAFT

Steele's Ad. Serv.

The **BLACKBURN AEROPLANE AND MOTOR Co., Ltd.**,
Olympia, **LEEDS**, and at Hull.

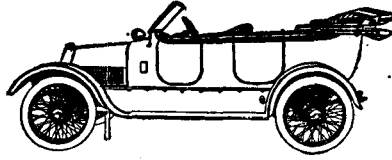

WHEN our energies are no longer concentrated on the manufacture of aeroplanes and aircraft engines our output will be resumed to the great advantage of the many motorists who are content to wait for post war HUMBER models.

HUMBER LIMITED, COVENTRY,
LONDON:—32, HOLBORN VIADUCT, E.C. 60-64, BROMPTON ROAD, S.W.

AGENTS EVERYWHERE

Humber

Speciality—HIGH GRADE
ALUMINIUM ALLOYS

HIGH TENSILE, FOR AERO WORK & OTHER SPECIAL REQUIREMENTS.

T. J. PRIESTMAN

✦ Metal Manufacturer ✦
and General Caster in all Metals

**OFFICIAL REFINER of ALUMINIUM
to H.M. MINISTRY OF MUNITIONS**



Cupro Foundry - Leopold Street - Birmingham

Established 1872. Telephones: Works, Midland 281; Offices, Midland 282

Buyer of Every Description of Aluminium Scrap and Swarf.

MANN ECERTON & Co.Ltd.

CONTRACTORS TO H.M. ADMIRALTY, WAR OFFICE,
AND AIR MINISTRY.

Designers and
Manufacturers of Proved
Efficiency of all Types of
AIRCRAFT

HEAD OFFICE AND WORKS

AIRCRAFT WORKS, NORWICH

SPECIAL DEPARTMENT
for the manufacture of
AIRCRAFT ACCESSORIES
(Strainers, Bolts and Nuts, etc., etc.)
177, CLEVELAND ST., LONDON, W.1.

MANN ECERTON & Co.Ltd.

LONDON NORWICH IPSWICH BURY ST. EDMUNDS.

G. D. PETERS & Co., LIMITED.

**WINDSOR WORKS,
SLOUGH,
BUCKS.**

**Contractors to
H.M. WAR OFFICE AND AIR MINISTRY.**

Telephones :
SLOUGH 201, 202, 203.
Victoria 2900, 2901.

London Office :
15, Dean's Yard, Westminster,
S.W.1.

Telegrams :
PETERS, SLOUGH.
Peters, London.

DUGARD BROTHERS, LTD.

ROLLED METALS. Brass, Copper, Bronze,
Gun Metal, etc., in Sheets,
Rolls, Strips, Foil and Circles.

TUBES. Solid drawn Brass and Copper Tubes, for Oil
Pipes, Petrol Pipes, Radiators and all Aircraft
requirements. Also Mandril drawn Tube for
Scientific and Optical Instruments.

RODS. Brass, Gun Metal and Bronze. Round, Hexagon
and Square.

**VULCAN MILLS, BRIDGE STREET WEST,
BIRMINGHAM.**

Telegrams : "VULCAN," BIRMINGHAM.

Telephone : CENTRAL 98.

We Specialise in the Manufacture

OF

DROP FORGINGS

FOR ALL TRADES.

SEND YOUR ENQUIRIES

TO

**JOHN GARRINGTON & SONS, LTD.,
ALBERT WORKS,
DARLSTON, STAFFS.**

Telegrams : "Garringtons, Darlaston."

Telephone : 53 Darlaston.

THE

**GNÔME AND LE RHONE ENGINE
COMPANY.**

CONTRACTORS TO THE
WAR OFFICE AND ADMIRALTY.

LONDON OFFICES :

47, VICTORIA STREET, S.W.1, AND THE HYDE, HENDON, N.W.

WORKS :

BLACKHORSE LANE, WALTHAMSTOW, E.17.

“SCEPTRE” supersedes “SUPER”

ANNOUNCEMENT



The SCEPTRE AVIATION Co., Ltd.

CONTRACTORS TO THE AIR MINISTRY.

Dudden Hill Lane, Willesden, N.W. 10

MANAGING DIRECTOR - N. LEWIN.

Telephone:—WILLESDEN 642 & 643 (2 lines)

Telegrams:—“SUPAVICOL, CRICK, LONDON.”

When we adopted the name of the Super Aviation Co., Ltd., we had no idea it was likely to clash with another Company's name, but it having been suggested some confusion has arisen by reason of the adoption of the word “Super,” and having no desire that this should be the result, we immediately offered to change our name on the matter being brought to our notice.

We therefore publish this announcement to acquaint our many customers that in future this business will be known as THE SCEPTRE AVIATION CO., LTD., and feel sure you will realise that though changed in name—the nature of the organisation remains the same—The Sceptre Aviation Co., Ltd., is as keenly anxious as ever to give you satisfactory service and to preserve your valued good-will.

SHORT & MASON, LTD.

Scientific Instrument Manufacturers,

ANEROID WORKS, MACDONALD ROAD, WALTHAMSTOW,



LONDON, E.17.

ESTABLISHED 1864.

Manufacturers of Aneroid Barometers and Barographs for Aeronautical Purposes.

Contractors to War Office, Admiralty, India Board, Meteorological Office,
Canadian and S. African Governments, Australian Commonwealth, &c.

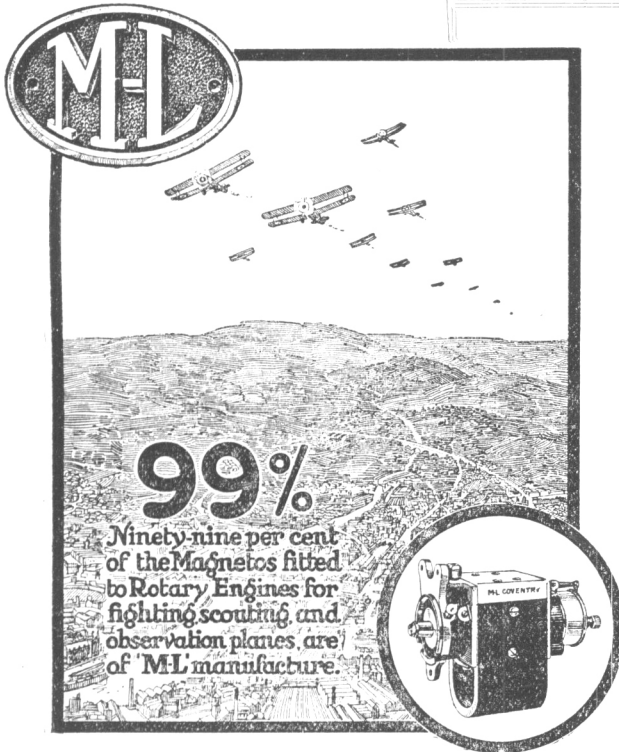

99%
Ninety-nine per cent of the Magnetos fitted to Rotary Engines for fighting, scouting, and observation planes, are of 'M-L' manufacture.

M-L Magnetos are lighter and smaller (yet stronger) than any pre-war magnetos of same electrical capacity. They are of British design and built by British labour in a British-owned factory. They have been supplied in large numbers for work of national importance.

The M-L Magneto, Type A.D.S., is designed for use on rotary or other engines in which the distributor is carried on the engine itself and does not form a part of the magneto. It is fitted with an "H" armature and gives two sparks per revolution.

THE
M-L MAGNETO SYND. LTD.,
VICTORIA WORKS
COVENTRY.

SANKEY

Pressings & Stampings.

WE have special facilities for turning out combinations of stamped or hydraulically pressed, rivetted and welded work of all descriptions, with or without machining, of any thickness from 20 gauge sheets to $\frac{1}{2}$ in. plates, in steel or other material.

Let us know your requirements and we will quote you.

JOSEPH SANKEY & SONS
LTD.
WELLINGTON, SHROPSHIRE.

W. G. TARRANT,

Contractor to Air Board.

Aircraft Head Offices :

BYFLEET, SURREY.

TELEPHONE: BYFLEET 1.

„ 2.

„ 3.

London Offices :

CLOCKHOUSE,

ARUNDEL STREET,

STRAND, W.C.

TELEPHONE: GERRARD 8362.

F. W. BERWICK

∴ & Co., Ltd. ∴

**AEROPLANE & AERO
Engine Manufacturers
TO THE AIR BOARD**



PARK ROYAL, LONDON, N.W.10.

Telephone: 2490 Willesden (5 lines).

Telegrams: "Berwicks, Harles, London."

BOULTON & PAUL, LTD
MAKERS OF AIRCRAFT **NORWICH**

IN the production of Aircraft in the Boulton & Paul Works we have two ideals—to furnish our customers with goods of the finest class, and our workers with the healthiest and happiest way of making their livelihood.

At present we are not in a position to consider any offer of further contracts. After the war our resources will be at the disposal of Great Britain and her Allies.



Telegrams: AVIATION. NORWICH
 Telephone: 851 NORWICH (5 lines)

FOUNDED 1797

BURTON, DELINGPOLE & CO



MANUFACTURERS OF

**CAPSTAN &
AUTOMATIC WORK**

IN BRASS, STEEL, GUNMETAL, ETC.,

FOR ALL BRANCHES OF THE
MOTOR & AEROPLANE INDUSTRIES.

DROPFORGINGS

STAMPINGS ONLY OR FINISHED—
MACHINED TO CUSTOMERS' REQUIREMENTS.

HEAD OFFICES: MOSELEY ST., BIRMINGHAM.

WORKS: BIRMINGHAM & OLD HILL (STAFFS).

GROVE GLUES

FOR AIRCRAFT

and all other purposes.

THE GROVE CHEMICAL Co., Ltd.,
APPLEY BRIDGE, near WIGAN.

Telegrams—"CROWN, APPLEY BRIDGE."

Telephone—12 PABOLD.

**THE
TALBOT-STEAD
TUBE CO., LTD.,
WALSALL.**

**Solid Drawn Steel Tubes.
Bright Drawn Steel Bars.
Bright Steel Nuts & Bolts.**

*11 Years' Experience in Drawing
Bright Bars.
Prompt Delivery for
Urgent War
Work.*

Tele-
phone :
276
277.

Tele-
grams :
Talbot,
Walsall

THE NAME —
“BEARDMORE”
 ON AERO ENGINES
 DENOTES EFFICIENCY.

THE BEARDMORE AERO ENGINE Ltd.
 London Showrooms & Depot: 112 Great Portland Street, London, W. 1.
 Telephone: 238 Gerrard.

C.D.C

The Alliance Aeroplane Company Ltd.

CONTRACTORS
 TO
 Ministry of Munitions of War
 Air Board.



Registered Offices :
 45, CASTLE ST. EAST
 LONDON
 W. 1.

CAMBRIDGE ROAD
 HAMMERSMITH.

NOEL ROAD,
 ACTON.

Telephone:
Central 1449.

Cable & Telegraphic Address:
"Canton," Sheffield.

THE

CANTON STEEL & TOOL CO.,

CANTON STEEL WORKS,
CORNISH STREET, SHEFFIELD.

Manufacturers of . . .

"Canton" High Speed Steel.

CAST & TOOL STEELS for EVERY DESCRIPTION of TOOLS.

AIRCRAFT STEELS to A.I.D. Inspection and Tests.

Contractors to H.M. Government.

On "Lloyd's Register."

Hors Concours Membre du Jury: Brussels International Exhibition, 1910.
Grand Prix London, 1908, and Buenos Aires, 1910.



Telegrams:
JONAS,
SHEFFIELD.



Telephone:
No. 4660.
PRIVATE BRANCH
EXCHANGE.



SIR JOSEPH JONAS, COLVER & Co., LTD.,

Manufacturers of Steel of every description, including
HIGH GRADE NICKEL STEEL and FORGINGS
for Naval and General Marine Purposes.

Special Heat Treated Alloy and other Steels for Aircraft and Automobile Purposes.

IMPORTANT SPECIALITIES:

S. S. G.

A SPECIAL NICKEL CHROME GEAR STEEL.

FOR AIR OR OIL HARDENING. When treated this steel has exceedingly tough properties and is specially suitable for Gear Wheels, Connecting Rods, etc.

S. G. W.

A NICKEL CHROME STEEL in 4 GRADES.

Eminently suitable and strongly recommended for Gears, Crankshafts, and other highly stressed parts, and having exceptional machining qualities. Combines unusually heavy shock-resisting and wearing properties with silent running.

G. P. S.

A HIGH GRADE ALLOY CASE HARDENING STEEL
for severely strained parts, such as Gear Wheels, Gudgeon Pins, etc.

Continental Steel Works and Novo Steel Works, Sheffield.

SANDERSON BROTHERS
& NEWBOULD, LTD.,

**ATTERCLIFFE FORGE and ROLLING MILLS,
SHEFFIELD.**

Makers of High-Class

**AIRCRAFT
STEELS**

**Either Rolled or Heat Treated
to**

AIR-BOARD SPECIFICATIONS.

Ask for our Special Book on

HIGH TENSILE STEELS.

BRITISH MADE CHUCKS.

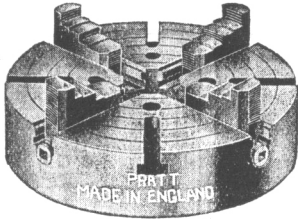

Independent 4-Jaw Chucks.

Reversible Jaws and Heavy Bodies.

Screws have Double-thrust Bearings (10in. size and upwards).
STANDARD SIZES:—4½, 6, 8, 9, 10, 12, 14, 15, 16, 18, 20,
22 and 24in. diam.

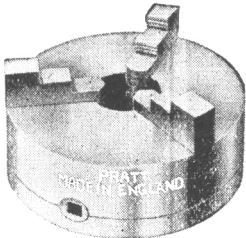

3-Jaw Geared Scroll Chucks.

Self-Centring.

SIZES IN PROGRESS : 6in., 7½in. and 9in. diam.

With One or Two Sets of Jaws as required.

Price Lists on Application.

Can be had from all Merchants and Dealers.

Manufactured by—

F. PRATT & CO., LTD., HALIFAX, ENG.

Telegrams : "Pratt, Halifax."

Telephone : No. 161.

W. CANNING & Co.,

MANUFACTURERS-OF

PLANT AND MATERIALS

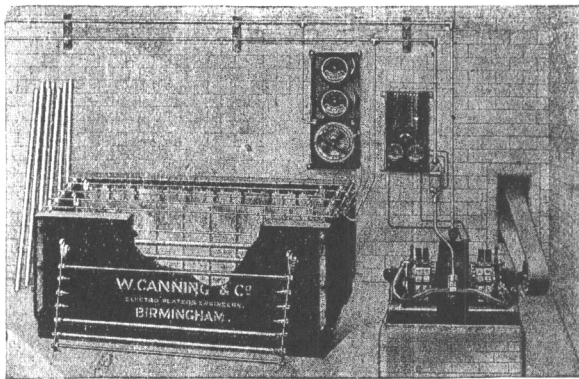

FOR

**ELECTRO-ZINCING,
NICKEL PLATING,
TIN PLATING,
LEAD PLATING,
COPPER PLATING,
BRASS PLATING,
SILVER PLATING,**

etc., etc.

**POLISHING MACHINERY AND MATERIALS.
ENAMELLING AND DRYING STOVES.
LACQUERING AND DRYING TABLES.**

Great Hampton St., BIRMINGHAM.

18-20, St. John's Square, Clerkenwell, LONDON.

GRAHAME-WHITE AVIATION CO., Ltd.

**AERONAUTICAL
DESIGNERS &
CONSTRUCTORS**

**CONTRACTORS TO
THE ADMIRALTY
AND WAR OFFICE.**

**PROPRIETORS OF THE
LONDON AERODROME
and the
GRAHAME-WHITE SCHOOL
OF AVIATION.**

HENDON.

— HEAD OFFICE AND WORKS: —
LONDON AERODROME, HENDON, N.W. 9.

TELEGRAMS: "VOLPLANE, HYDE, LONDON."

TELEPHONE: KINGSBURY 120 (Five Lines)



W. H. ALLEN SON & CO. L^{TD.}

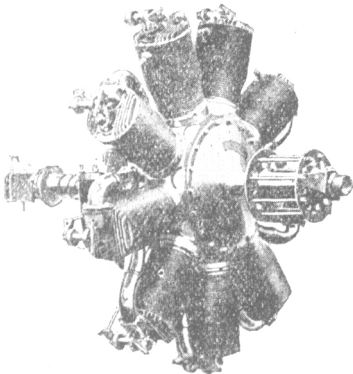

AIRCRAFT ENGINES

QUEEN'S ENGINEERING WORKS, BEDFORD.

“ NIEUPOORT ”

— AND —

General Aircraft Company, Ltd.

Contractors to H.M. Government.

REGISTERED OFFICE AND WORKS:

**LANGTON ROAD, CRICKLEWOOD,
LONDON, N.W.2.**

Telephone (3 lines):
WILLESDEN 2455.

Telegrams:
NIEUSCOUT, CRICKLE, LONDON

A FEW LABOUR SAVING DEVICES

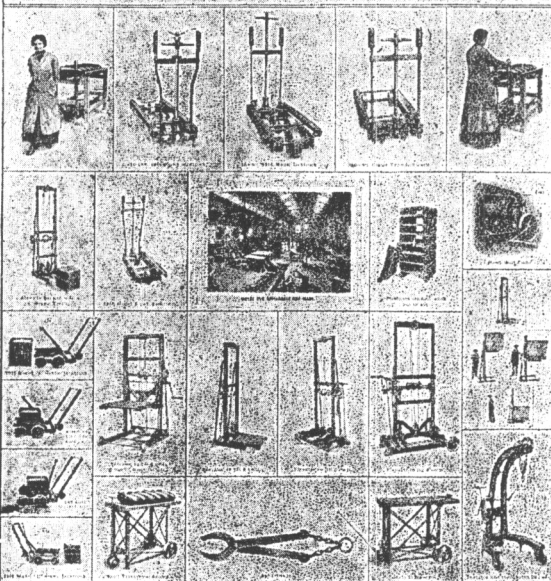

SOLE PATENTEE: JOHN T. HARDAKER, LTD., BOWLING IRONWORKS, BRADFORD, YORKS.
 BRANCHES: LONDON, BELFRAVE, GLASGOW, BIRMINGHAM, MANCHESTER, SHEFFIELD, LEEDS, NEWCASTLE, ABERDEEN, GLASGOW, BIRMINGHAM, MANCHESTER, SHEFFIELD, LEEDS, NEWCASTLE, ABERDEEN.

HARDAKER'S Patent JACKTRUCKS.

Specially designed for transporting
Aeroplane Engines on working
benches.

Used by all the leading Aero
Engine makers and Aircraft
Stores, etc.

Write for full Illustrated
Catalogue to

(Sole Makers and Patentees):

**JOHN T. HARDAKER,
LTD.,**

(AERO TRUCK DEPT.),

**Bowling Ironworks,
BRADFORD, YORKS.**

Telegrams: "GIMP, BRADFORD."
Telephone: 120 DUDLEY HILL.



BEING wholly engaged upon production for the British and Allied Governments, we regret that we are unable for the present to execute any orders for private purposes.

*Established
 1897.*

Victoria Road, Willesden Junction, N.W. 10.

Godbolds.

Thomas Andrews & Co. Ltd.

— ROYDS WORKS AND — **SHEFFIELD.**
 HARDENITE STEEL WORKS

High Class **ALLOY STEELS**

MADE TO AIR BOARD AND E.S.C. SPECIFICATIONS

FOR AIRCRAFT AND
AUTOMOBILE CONSTRUCTION

Telegrams—Bits, B'ham.

ESTABLISHED 1800.

Telephone—355 Northern.

R. COOPER & SONS LTD.

10 YEARS' EXPERIENCE IN

THE MANUFACTURE OF

AIRCRAFT

METAL

DETAIL FITTINGS, COMPONENTS,

TANKS,

EXHAUST PIPES, COWLINGS, ETC.

40, High Street, Aston New Town, BIRMINGHAM.

Contractors to the Admiralty and Air Board.



THE CENTRAL AIRCRAFT COMPANY,

**DESIGNERS AND CONSTRUCTORS
OF AIRCRAFT.**

Office and Works:

KILBURN, N.W.6.

Telegrams: AVIDUCTION, PHONE, LONDON.

Telephone: HAMPSTEAD 4403, 4404.

THE ALUMINIUM CASTINGS CO. LD

ESTABLISHED 1901.

SOUND CASTINGS.

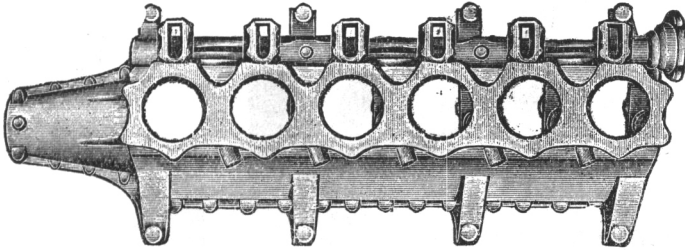

PROMPT DELIVERIES.

**Ingleston Foundry, GREENOCK,
SCOTLAND.**

TERRY

**Quality means Service,
Accuracy and Precision.**

MICROMETRIC accuracy—precisional action—and a quality of production, seasoned by more than 60 years' manufacturing experience.

That is TERRY Service!

For WARWORK we invite your inquiries for prices and delivery dates for Springs—Hose-clips — Presswork — Cable-work — Flexible Shafts, &c.

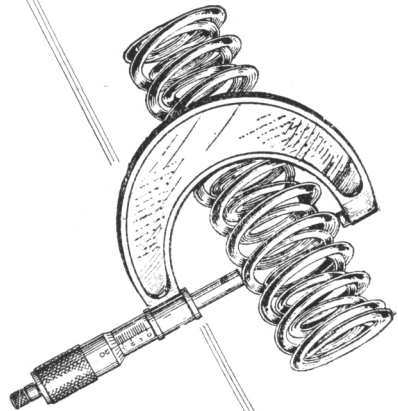

HERBERT TERRY & SONS LTD.,
The Spring & Presswork Specialists—
Redditch, England.
Telephone 61 (4 Lines).

P **FOR**
AERO ENGINES.

U

**OIL,
AIR,
WATER,
PETROL.**

MANUFACTURED BY

M

THE

SELSDON

P

AERO & ENGINEERING CO., L^D.

**1, ALBEMARLE STREET,
PICCADILLY, W.1.**

S.

Anti-Friction BEARINGS

FOR ALL PURPOSES.

TO ENSURE

ACCURACY, EFFICIENCY, AND ECONOMY,

instal **ANTI-FRICTION BEARINGS** made and lined under

THE WALKER-HANNA PATENTS

FOR

**MOTOR CARS, ELECTRIC MOTORS, TRAMWAYS,
AND ALL OTHER PURPOSES.**

**NO MACHINING REQUIRED, absolute INTERCHANGEABILITY with
those you are at present using.**

Write us on any question concerning Bearings.

WALKER-HANNA BEARINGS, Ltd.,

IMPERIAL WORKS, GREAT JACKSON STREET,

WEST GORTON, MANCHESTER.

'Phone: 85 OPENSHAW.

AGENTS—

E. T. WHITE & CO., Albemarle Mansions, 1 Albemarle Street, Piccadilly, London, W.1.

'TRIPLEX'
GIVES
PERFECT
VISION
AND
ABSOLUTE
SAFETY.

IT
CANNOT
BE
SPLINTERED.



'TRIPLEX'
IS THE
ONLY
SAFETY

GLASS FOR
WINDSCREENS,
OBSERVATION
PANELS,
GOGGLES, Etc

GOGGLES FROM
7/6 PER PAIR.

'TRIPLEX' SAFETY GLASS

Manufactured Solely by

The 'Triplex' Safety Glass Co., Ltd., (Reginald Delpech, Managing Director).
1, Albemarle Street, Piccadilly, London, W.1.

W. GILBERTSON & CO.,

LIMITED,

PONTARDAWE, GLAMORGAN.

Contractors to Admiralty, War Office, India Office, etc.

Manufacturers of Special Steels of all kinds.

STEEL BARS.
STEEL BILLETS.
SPECIAL STEEL.
HIGH CARBON STEEL.
ALLOY STEEL.
GALVANISED SHEETS.

CAPACITY OF OUTPUT

**3,000 tons
per week.**

CORRUGATED SHEETS.
BLACK SHEETS.
ARMATURE SHEETS.
TINPLATES.
TERNE PLATES.
ALUMINIUM Coated Plates

SUTCLIFFE.

WARMING
AND VENTILATING
PLANTS

FOR DOPE ROOMS.

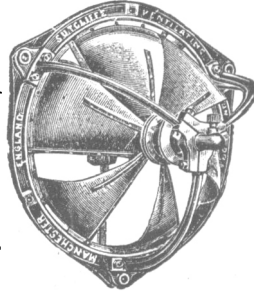

DUST COLLECTING
PLANTS

FOR GRINDING and
POLISHING SHOPS.

CONTRACTORS TO THE WAR OFFICE AND ADMIRALTY.

Ask for copy of New Booklet, just issued, "The Warming and Ventilating of Dope Rooms and Aeroplane Factories to satisfy Home Office requirements." Sent post free on request.

SUTCLIFFE VENTILATING & DRYING Co., Ltd.,

**Cathedral Gates,
MANCHESTER.**

T.N.—3920 City Manchester.

T.A.—Ventilabro, Manchester.

MARTINO'S TREATING AND TESTING WORKS LTD.

HEAT TREATMENT OF STEEL TO AIR BOARD SPECIFICATIONS.

Telephone:
No. 845
COVENTRY.

**NORMALISING.
ANNEALING.
HARDENING.
OIL QUENCHING
and TEMPERING.
CASE HARDENING.**

Telegrams:
"QUENCHING,"
COVENTRY.

MECHANICAL TESTING. ⚙️ CHEMICAL ANALYSIS.

SANDY LANE, COVENTRY.

HOYT BEARING METALS,

IN LARGEST USE FOR AERO ENGINES.

300-H.P.
"GREEN"
AERO
ENGINE.

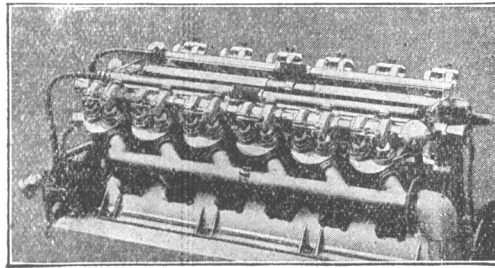

BEARINGS :
HOYT
METAL
LINED.

NUMBER ELEVEN—THE WORLD'S BEST.

OUTLASTS ALL OTHERS.

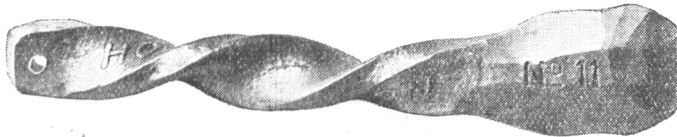

ABSOLUTELY THE HIGHEST QUALITY WHITE METAL MADE.
SPECIMEN TWISTED AND HAMMERED COLD, SHOWING TOUGHNESS.
COMPRESSION REQUIRED TO CRACK TEST SAMPLES: 20'55 TONS SQ. IN.

THE HOYT METAL CO., LTD.,

(WORKS : MILLWALL, E.) 189, HAMMERSMITH ROAD, LONDON, W.6.

PETTERS LIMITED.

**AIRCRAFT CONSTRUCTORS
TO THE ADMIRALTY.**

Orders can be accepted for
**Complete Machines
Propellers
Parts.**

WESTLAND AIRCRAFT WORKS

(Branch of Petters Limited),

YEovil, ENGLAND.

Telegrams : "Aircraft-Yeovil."

Telephone : Yeovil 129.

THE SOPWITH

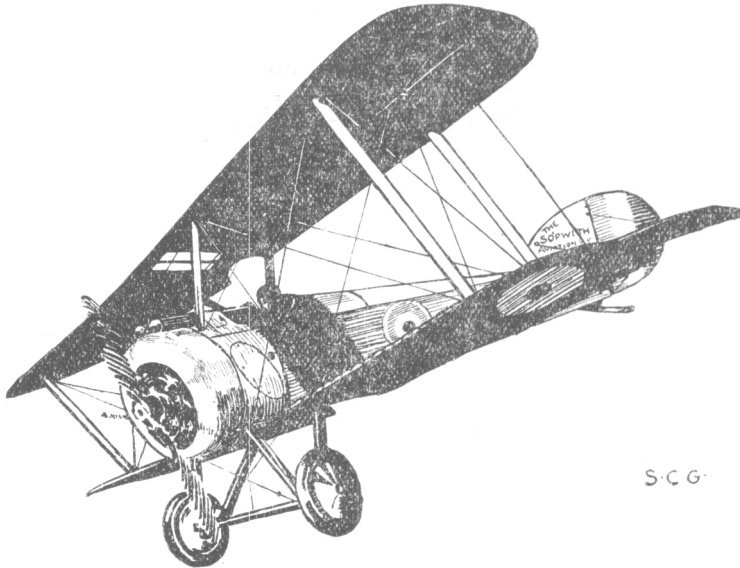

S.C.G.

AVIATION COMPANY, LIMITED
KINGSTON-ON-THAMES, ENGLAND.

CONTRACTORS TO H.M. GOVERNMENT.

Telephone: KINGSTON 1988 (8 lines).
Telegrams: SOPWITH, KINGSTON.



Paris Office:
21, RUE DU MONT THABOR.

The Aëronautical Journal.

THE ORGAN OF THE ROYAL AËRONAUTICAL SOCIETY.

CONTENTS, JULY, 1918.

For the opinions expressed in papers that are signed or initialled the authors alone are responsible. None of the papers or paragraphs must be taken as expressing the opinion of the Council of the Royal Aëronautical Society, unless such is definitely stated to be the case.

	PAGE
I. NOTICES	209
II. THE WIND CHANNEL: ITS DESIGN AND USE, BY J. R. PANNELL, A.M.I.M.E.	211
III. PROCEEDINGS OF SECOND MEETING, 53RD SESSION	241
IV. ABSTRACTS	249
V. BIBLIOGRAPHY	251
VI. RECENT ADDITIONS TO THE LIBRARY	251
VI. ABRIDGMENTS OF RECENT PATENT SPECIFICATIONS (AERONAUTICS)	252

All communications respecting Editorial Matters should be addressed to—

THE EDITOR, 7, Albemarle Street, W.1.

Telegrams: "DIDASKALOS, PICCY, LONDON."

TELEPHONE: 7373 GERRARD.

All communications respecting Advertisement Matters should be addressed to—

The Advertisement Manager, 63, Ludgate Hill, London, E.C. 4.

AEROPLANE and AIRSHIP COMPONENTS.

TRADE MARK.



MEANS LONG LIFE.

WE ARE MAKERS of tubular and press-work parts, steel tubing in all qualities, sections and gauges, plain and manipulated, including welding, tapering, flanging, brazing, necking, expanding, clipping, slotting, etc.

We are also makers of aircraft ferrules in all sizes and patterns, "Apollo" tubular box spanners, and "Apollo" Mykarms—a tool for temporarily turning any micrometer into a high or low limit gauge.

SEND FOR OUR LISTS

The firm with the widest aircraft experience.



OLDBURY, BIRMINGHAM.

Telegrams: "Accles, Oldbury."

Telephone: Oldbury III (4 lines).

Code: A.B.C. 5th Edition.

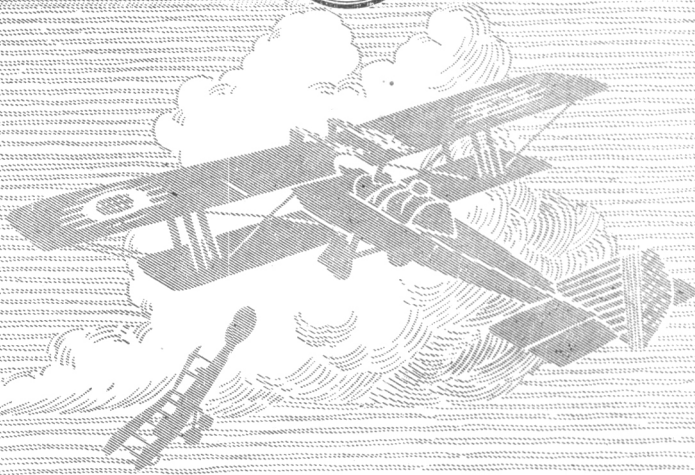

B.L.I.C.

THE BRITISH LIGHTING & IGNITION CO. LTD.

MODERN WARFARE is the supreme test of all mechanism—whatever the circumstances, it must not fail. And under these strenuous conditions the "B.L.I.C." Magneto has fully demonstrated its unrivalled superiority. Built in a British factory by British workmen, it is the most reliable Magneto yet constructed—British or foreign.

THE BRITISH
LIGHTING AND
IGNITION
CO., LTD.

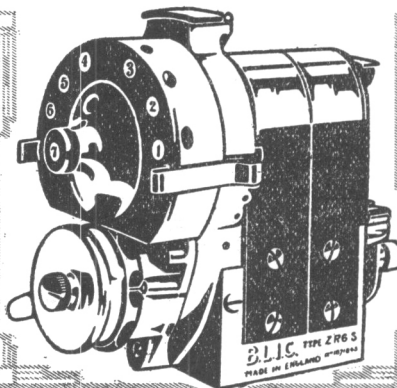

204, TOTTENHAM
COURT ROAD,
LONDON, W.
Proprietors: VICKERS, LTD.