

Additive manufacturing in fluid power with novel application to hydraulic pump design

Anton Wiberg , Liselott Ericson, Johan A. Persson and Johan Ölvander

Linköping University, Sweden

 anton.wiberg@liu.se

Abstract

Additive Manufacturing (AM) enhances component functionality in engineering. This study explores AM benefits for hydraulic pumps, by reviewing literature on fluid power and existing AM successes in pumps, pipes, and manifolds. While hydraulic pump research is scarce, the study redesigns a pump, mirroring successes in other hydraulic areas. Predicted outcomes include a 45-85% pressure drop reduction, 35% weight reduction, and fewer parts compared to traditional pumps, achieved with minor design changes. Larger-scale redesigns promise even greater improvements.

Keywords: additive manufacturing, fluid power, case study

1. Introduction

Additive Manufacturing (AM) is a group of manufacturing technologies which builds three dimensional objects by successively adding layers of material upon each other. The process allows creation of complex geometries at the same cost as simpler ones. An application which takes advantage of the possibilities of AM is the creation of internal channels, the manufacturing of which would not be possible, or at least not economically feasible, with other techniques such as drilling or casting. These possibilities have been used to create better products in various industries such as aeronautics (Blakey-Milner et al., 2021), gas turbines (Gebisa and Lemu, 2018), and automotive (Vasco, 2021). In these cases, improved flow characteristics in heat exchangers (Robinson et al., 2018), cooling within tools, and different kinds of manifolds (Semini et al., 2015) have shown potential to improve the products. Overall earlier studies have shown that pressures losses and flow characteristics in these types of components can be improved from 25 (Alshare et al., 2019) up to 250% (Cooper et al., 2012).

While application of AM in other industries have been thoroughly investigated the context of hydraulic power and more specifically high-pressure hydraulic pumps is not as well investigated. This work contributes to the field by exploration of the feasibility of utilizing AM in fluid power applications, with a specific focus on hydraulic pumps. The objectives of this paper are to (1) review the current state-of-the-art applications of AM in hydraulic power, (2) assess the design and manufacturing challenges and opportunities associated with the use of AM in hydraulic pumps, and (3) identify the potential product advantages that can be achieved through the application of AM in the manufacture of hydraulic pumps. Compared to existing applications, a hydraulic pump adds complexity with moving parts such as pistons and check valves. The components in a pump are traditionally manufactured by a combination of casting and subtractive manufacturing techniques. These manufacturing processes place constraints on the possibility of fully optimizing the components.

This work presents a review of previous research that has been performed in the field of AM for the manufacturing of pumps (section 2). From this a hydraulic axial piston pump of the check valve pump

([Ivantysyn and Ivantysynova, 2003](#)) is analysed, redesigned for AM, and evaluated to see which advantages AM can provide (section 3). A discussion regarding the pump redesign and future directions (section 4) and conclusions of the work (section 5) finalises the paper.

2. Related work

Additive Manufacturing is a standard term coined by ISO and ASTM (“[SS-EN ISO/ASTM 52900:2017](#),” [2017](#)) for a manufacturing process which successively adds material where it is wanted. AM is not one process or material – instead it can be divided into seven categories: Vat Photopolymerization, Material Extrusion, Material Jetting, Binder Jetting, Powder Bed Fusion (PBF), Direct Energy Deposition, and Sheet Lamination ([Gao et al., 2015](#)). Most of the identified research in AM of hydraulic components uses Powder Bed Fusion (PBF) AM techniques to manufacture final metal parts. Other alternatives do exist, such as polymer AM methods ([Roper et al., 2015](#)), AM manufacturing of cast forms ([Lei et al., 2018](#)), and the use of novel AM techniques to create composite materials ([Arie et al., 2020](#)). In PBF metals including aluminium alloys, different kinds of steel, titanium alloys, and nickel alloys ([Gao et al., 2015](#)) can be manufactured ending up in components with relative density of around 97-99% ([Yakout et al., 2019](#)) and material properties comparable to wrought material ([Frazier, 2014](#)).

Redesigning hydraulic manifolds to take advantage of the possibilities offered by AM is a subject which has drawn attention from the industry over the last few years ([Smelov et al., 2020](#)). AM applied to manifold designs offers possibilities which include reduction of component mass, part consolidation, and reduction in pressure losses. Studies show that mass can be reduced by 30-80% compared to designs with the same functionality manufactured using traditional manufacturing methods ([Alshare et al., 2019](#); [Pavel et al., 2018](#); [Semini et al., 2015](#); [Smelov et al., 2020](#)). The gain in weight reduction can be explained by the over-dimensioned design involved in subtractive manufacturing methods, which start with a block of material and where each additional manufacturing operation adds cost to the final product.

The cost for AM is not easy to directly compare against other manufacturing methods – instead it is often necessary to analyse the cost from a product lifecycle perspective ([Lindermann et al., 2012](#)). Machine and material costs for advanced AM are high, and the manufacturing process is also relatively slow. On the other hand, the process is automated and there is no need for fixtures, molds, or other equipment. This results in a cost curve where the price for manufacturing of one piece is not that much more expensive (per unit) than the manufacturing of thousands. Another advantage from a cost perspective is the potential for part consolidation, where several parts are combined into one ([Yang and Zhao, 2015](#)). By decreasing the number of parts in a component, the number of assembly operations and the scrap rate due to errors in assembly are reduced ([Yang et al., 2015](#)). In hydraulic applications, part consolidation can also reduce the risk of leakage in the system. Overall, the manufacturing cost of AM components is often higher than conventional manufactured parts, so to gain value from using AM, either the part’s functionality or the delivery chain needs to be improved.

Compared to a design manufactured by a laminate strategy of cross sections brazed together, AM has been shown to reduce pressure loss in the system by 44% ([Chekurov and Lantela, 2017](#)). Another manifold example has shown a reduction in pressure loss of 25% ([Alshare et al., 2019](#)), and improved flow characteristics of 250% ([Cooper et al., 2012](#)). [Liu et al. \(2019\)](#) show that the pressure losses of 90 degree pipe bends can be reduced by up to 50% if the bend is AM manufactured with a controlled radius in comparison to drilled bends.

Several studies have confirmed that AM can be used in pressures above 20 MPa without any leakage ([Alshare et al., 2019](#); [Chekurov and Lantela, 2017](#); [Cooper et al., 2012](#); [Matthiesen et al., 2020](#); [Semini et al., 2015](#)). Systems with pressures of 20-25 MPa have been showcased in e.g. ([Chekurov and Lantela, 2017](#); [Semini et al., 2015](#)), and [Cooper et al. \(2012\)](#) showcase a system which handles a pressure of 25 MPa with a wall thickness as small as 0.5 mm manufactured in Ti-6Al-4V. [Semini et al. \(2015\)](#) show similar practical verifications but of 1 mm thick AlSiMg channels. In addition to titanium and aluminium alloys, maraging steel shows potential for use in high pressure hydraulic systems, see ([Chekurov and Lantela, 2017](#)).

Alongside a redesign of manifolds, [Matthiesen et al. \(2020\)](#) showcase how an internal gear pump can be redesigned for AM. Check valves and other movable features cannot be manufactured in one piece since they generally require a higher tolerance than what can be achieved with AM. The results show

promising results with a lighter, more space-effective, and higher-performance product. Both Matthiesen, and Neubauer and Durfee (2016) state that functional surfaces which require a narrow tolerance, such as movable parts and interfaces to other components, require machining.

To include more functionality in the design Wits et al. (2013) discuss how no moving check valves can be built directly by AM and therefore be built into a larger structure. The results show that it works in micro contexts, but no larger scale hydraulic flows are investigated.

Overall, earlier studies show that utilising AM and DfAM methods for fluid applications make it possible to create designs with significantly better flow and heat exchange properties compared to traditionally designed and manufactured parts. Earlier studies also show that parts manufactured by PBF AM can withstand high pressure applications necessary to be able to manufacture pumps. To reduce pressure loss the design should focus on removing sharp bends (which often happens when e.g. flow channels are drilled) but also avoid manufacturing overhangs to reduce surface roughness. Another AM feature which has potential to improve designs is part consolidation, where several parts are included into one, which have the potential to remove unnecessary parts intersection causing worse flow characteristics and risk of leaks.

3. Novel hydraulic pump redesign

This section introduces a case study where the lessons learnt from related work are implemented into the re-design process of a hydraulic pump. The overall goal with this study is to validate that the advantages identified for other similar products is transferable to the design of a high-pressure hydraulic pump, a topic which is not well covered in earlier studies. The design should be able to withstand the same pressures and requirements as today's pump but with better performance. To be able to easily compare the outcome with the existing solution it was decided to keep the main interfaces and design the same even though a larger redesign probably have the possibility to add even more value to the design.

The redesign is split into three phases, an analyse of the current pump including limitations of the design and potential re-design opportunities, the redesign phase, and finally an evaluation phase where the new and old designs are compared. The redesign followed the overall design methodology presented by Wiberg et al. (2019) where focus was on the system and part design steps. During the system design step, concept generation and ideation methods were used to identify the boundaries between the individual components and different potential overall designs was identified. During the part design step a design automation framework presented in (Wiberg et al., 2023) was utilised. This framework allows easy creation of parametric flow and structural features which can be adopted to specific needs and allows automatic creation of simulation models. In this case an analytic flow model is created which analyses the individual features of the model and based on this calculates the overall pressure loss (presented in section 3.3).

3.1. Hydraulic pump of wobble plate pump

The power supply in a hydraulic system is a positive-displacement pump of swash-plate pump type which consists of a barrel where the pistons are located and a swashplate with a defined angle. For the pump considered in this research, the barrel stands still, and the swashplate rotates with the drive shaft, see (Murrenhoff, 2014). This creates a wobbling movement of the swashplate and hence the name wobble plate pump. The pump works by the rotating wobble plate moving the pistons in a linear motion in the cylinders. The piston moves with a velocity v_{piston} which depends on the rotational speed of the input axis and the angle of the swashplate. The commutation, i.e. the switching between high and low pressure for individual cylinders, is an important aspect of a pump design and can be realized in different ways for the above two designs. The most common approach is to use a valve plate with rotational dependent commutation. A wobble plate pump can use check valves which open and close depending on the pressure difference at the outlet/inlet port ($p_{out/in}$) and cylinder volume (p_{piston}), i.e. pressure dependent commutation. The pump has a very low noise level and high volumetric efficiency. The drawback is the limited rotational speed due to pressure drops in the pipe system and the check valve and the unbalanced mass of the wobble plate.

The considered pump contains one inlet, and ten cylinders where five (each second) lead to outlet 1 and the other five lead to outlet 2. Check valves which make sure that the flow is in the correct direction are placed between the inlet and cylinder and between the cylinder and the outlet. An overview of the pump is presented in Figure 1a. Since the function of the pump is to create high pressure in the outlets, an important factor for the performance is the system pressure loss. In this study it is defined as the difference between the pressure within the piston and the outlet as defined in equation 1 and 2.

$$\text{Pressure loss Outlet 1} = p_{\text{Piston}} - p_{\text{Out1}} \quad (1)$$

$$\text{Pressure loss Outlet 2} = p_{\text{Piston}} - p_{\text{Out2}} \quad (2)$$

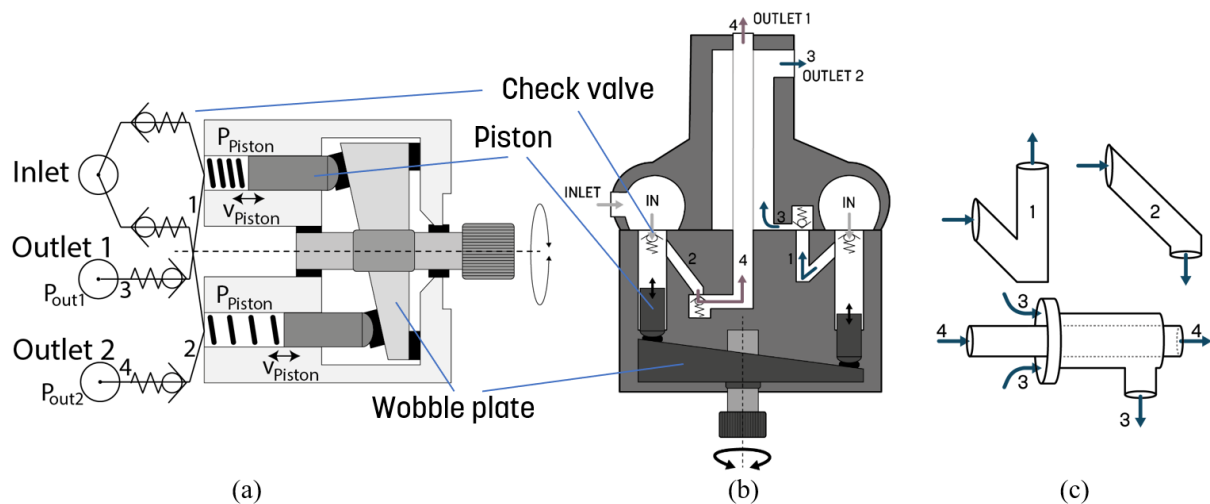

Figure 1. Overview of the current pump design

Today's pump is manufactured by a combination of casting, milling and drilling, which limits the geometry possible. From a pressure loss perspective, the manufacturing method constrains the design alternatives for the hydraulic channels between the cylinders and the two outlets. In Figure 1a, channels 1 and 3 are placed between the cylinders and outlet 2, while channels 2 and 4 lead the flow to outlet 1. Figure 1b shows a cross-section of the pump and an illustration of the channel's geometries.

The two outlets are designed as two pipes, one with a small diameter and the other with a larger one. The flow in outlet 1 comes from the small pipe (channel 4), while the flow from outlet 2 streams within the larger pipe but on the outside of the small one it also ends in a sharp 90 degrees bend at the outlet (channel 3), see Figure 1c. Channels 1 and 2, which lead the flow between the cylinders and the outlet check valves, are drilled in the piston block. Therefore, these are straight with sharp bends. While the bend in channel 2 is 45 degrees, the bend in channel 1 is 135 degrees, as shown in Figure 1c. A quantitative analysis of the mass, flow characteristics and number of parts of the old design, is presented together with the analysis of the new design in section 3.3.

3.2. Component redesign

The redesign process started with an analysis of the current pump system (presented above). From the literature analysis (presented in section 2) together with discussion with component experts, two ways to improve the pump with AM were identified, the first is optimization of internal channels to reduce pressure loss between the cylinders and the outlet. Second is reduction of the number of components within the pump, which can save time and cost in assembly, reduce the risk of manufacturing errors, and reduce the potential risk of leakage. Based on the system analysis, the system design focused on investigation into whether components could be integrated into one. Based on concept ideas from the system design, the individual parts were designed, and during this process the focus was on creating channels that were as straight as possible while respecting the structural integrity.

To be able to compare the redesign with the current one, only the geometry between the pistons and the outlets was changed, while other parts of the pump were kept constant. Therefore, no changes to the inlet, piston size or positions, or the check valves were made. The largest change compared to the

original design is that the new design adopted for manufacturing by AM has two parallel outlets. Channels 1 and 2 (in Figure 1 b-c) are also redesigned with the aim of reducing pressure loss by avoiding sharp bend angles and maximizing the bend radiuses (see Figure 2 and 3). The cross-sections of the channels are changed from circular to a drop shape (as shown in Figure 2) where the top radius, drop angle and direction are chosen to avoid support material during manufacturing by AM. The large radius (R) is chosen so the channels receive the same cross-section area as the old channels. Two parallel outlets are achieved by creating half circles which transform to full circles at the end (compulsory for standard connection). As in the original design, outlet 1 connects to the flow from the convergence flow in the piston block. As the outlets are parallel, portions of the flow to outlet 2 need to circuit outlet 1. This is achieved by channels which bend around the outlet and intersect the flow in outlet 2, see Figure 3a-b.

No detailed structural analysis has been performed of the redesigned pump system – instead the structural integrity was ensured with the selection of a minimal wall thickness verified for the system pressure in studies found during the literature review. This was also compared to a simple finite element analysis of the channel pressure. The final selection of AM process, machine, and material has not been made but the proposal is to manufacture it by laser PBF AM in maraging-, tool- or stainless steel. During the structural verification and weight analysis, the material was assumed to be maraging steel, with material properties from conventional manufactured alloys.

The system was designed with a minimum wall thickness of 3 mm, which is three times higher than what is verified by [Chekurov and Lantela \(2017\)](#) for a system with 25 MPa hydraulic pressure. An FE model was used to verify the static strength, based on a pressure of 50 MPa everywhere in the system. The stress was shown to be well within the yield strength of the material.

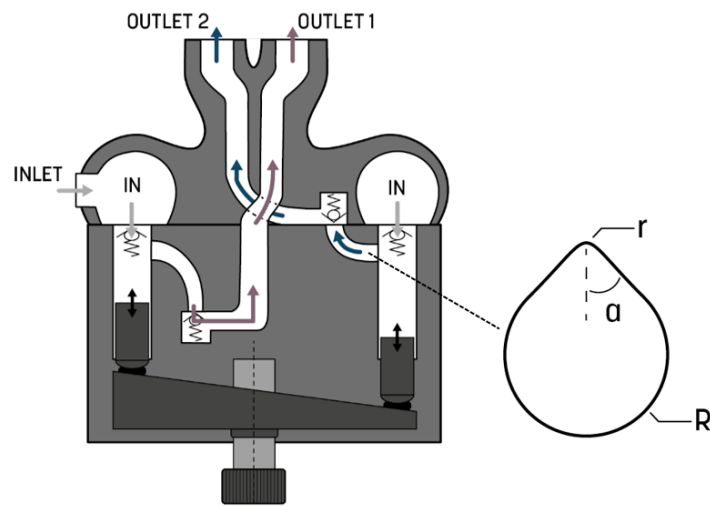

Figure 2. Overview of new design

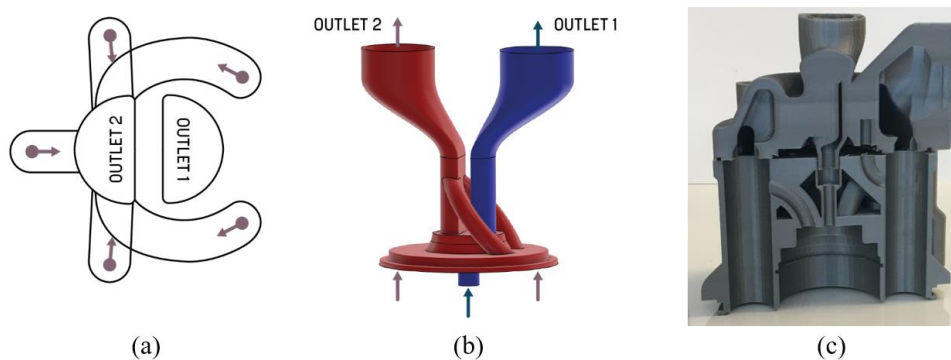

Figure 3. Details of new design

A plastic model of the pump was test-printed (see Figure 3c) to be able to analyse the geometry on a physical model. Meisel et al. (2017) state the importance of using simpler plastic methods to validate fit and form in a cost-effective way. In this case, the model was used to obtain a first verification of the manufacturability and to review potential critical areas, both from a manufacturing and a fluid perspective.

3.3. Component evaluation

3.3.1. Flow

To compare the performance of the new pump design and the original design, the pressure loss of the different pumps was compared. As a first approximation, the pressure losses in the system were evaluated with a flow model based on simple hydraulic channel flow equations derived from Bernoulli's extended equation for stationary incompressible flow (Çengel et al., 2017). Pressure, flow velocity, and height factors were neglected, and hence only geometrical flow losses were included. The pressure loss is divided into friction and single losses. The friction losses are influenced by the friction factor (λ), channel length (l), hydraulic diameter (d), pressure (p), and flow velocity (v) and calculated according to equation 3. While the pressure and flow velocity are given for the case, the friction factor is calculated based on the Reynolds number, which is influenced by the hydraulic diameter. Both the length and hydraulic diameter are based on the geometry model.

The single losses included are created by some kind of disturbance source, in this model, the losses due to bends in the flow system are included. The loss of a bend is calculated according to equation 4, where the single loss factor (ζ) is calculated based on the bend radius, angle, and channel diameter, all extracted from the CAD model. In addition to bends, the check valves in the system are treated as single losses calculated as shown in equation 5. The loss at a check valve is dependent on the spring constant (k), spring deformation (δ), and diameter of the check valve (d_c).

$$\Delta p_f = \begin{cases} \lambda \frac{l}{d} \frac{pv^2}{2} & \text{at a straight distance} & (3) \\ \zeta \frac{pv^2}{2} & \text{at a bend} & (4) \\ 4 \frac{k\delta}{d_c^2 \pi} & \text{at a check valve} & (5) \end{cases}$$

The same model was used both on the original pump design and the redesigned pump. The pressure loss of the system is defined as the pressure difference between the piston and the outlet, as presented in Figure 1, equations 1 and 2. Flow velocity in the simulation is calculated based on the piston's movement, where a faster revolutionary speed results in a higher piston velocity and thereby a higher flow velocity. Three alternative rotations per minute of the pump (500, 750, and 1000) were compared. In an earlier study (Kärnell et al., 2018), the pressure loss for outlet 1 was both calculated (with a more advanced model than the one applied in this paper) and measured, but no measurements or calculations were performed on outlet 2. The measured and calculated pressure, together with the calculated pressure loss for the original and redesigned pump in this study is presented in Table 2. Rows 1 and 2 in the table show that the simulation model in (Kärnell et al., 2018) is good. Rows 1 and 3 show that the model in this study is acceptable, with an average deviation of 9.8% compared to measurements. Row 4 complements the old study by calculating the pressure drop at outlet 2. The increased losses for outlet 2 compared with outlet 1 can be explained by the sharp channel bend, the double walled outlet (which leads to friction losses), and the sharp bend just before the outlet, all presented in Figure 3. Finally rows 5 and 6 in Table 2 show that the pressure losses for the redesigned pump are on average half that of the losses for outlet 1 in the original design, and even lower for outlet 2. It can also be stated that the pressure losses for the two outlets in the redesign are much more uniform.

Table 1. Comparison between simulation models and measurements

Study	Outlet	Pressure loss (MPa)			
		500 rpm	750 rpm	1000 rpm	
1	Original design calculated in (Kärnell et al., 2018)	1	0.59	0.65	0.72
2	Original design measured in (Kärnell et al., 2018)	1	0.59	0.66	0.74
3	Original design calculated based on equations (1)-(5)	1	0.55	0.68	0.85
4	Original design calculated based on equations (1)-(5)	2	0.91	1.72	2.60
5	Redesign calculated based on equations (1)-(5)	1	0.30	0.34	0.40
6	Redesign calculated based on equations (1)-(5)	2	0.29	0.33	0.37

3.3.2. Structure

During the redesign, the part count in the assembly was reduced by integrating three parts into one. This also results in the removal of two sealings. The part integration together with the creation of two parallel outlets creates a more compact design where the height is reduced. The manufacturing technique also allows a more complex design where material can be reduced. A weight reduction of around 3 kg (equal to 35% of the original weight) was achieved by creating a slimmer overall design and a hollow part within the piston block. The hollow part is designed with small channels to be able to remove the powder which is used during manufacturing. It was considered to add lattice structures as infill but powder removal issues together with the fact that a solution with lattice inside walls have not been proved to be pressure safe in earlier studies restricted this solution. The created design could not be manufactured with any manufacturing technique other than AM. A comparison between the old and redesigned component is shown in Figure 4.

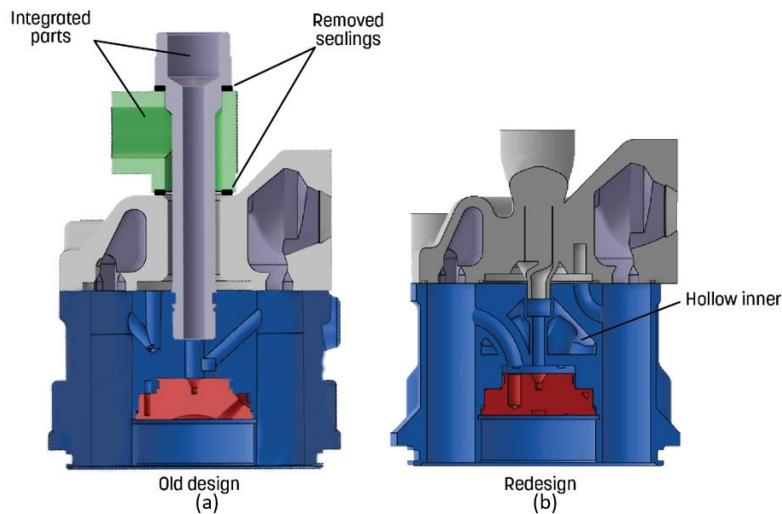

Figure 4. Comparison of old and new design

4. Discussion

The literature review presented in section 3 shows that AM is applied in various fluid applications and has the potential to improve functionality in terms pressure loss, heat exchange, leakage, and mass reduction. General advantages of AM also state that AM can open up the possibility of creating customer-specific solutions on a small scale without an increase in manufacturing cost. As presented in section 3.2, for mass-produced components AM is still an expensive method and a reduction in assembly cost (due to part reduction) and improved functionality must compensate for the high manufacturing cost. The application of AM to hydraulic pumps is still relatively scarce but with major potential, as will be discussed below.

4.1. Hydraulic pump redesign

The redesign process in this work focused on relatively small changes to the pump, such that flow inlet, pistons, and check valves were not modified, resulting in a small design space that makes it difficult to perform any large innovations regarding the pump design. However, the freeform possibilities of AM and the drop-shaped cross-section of the channels between the pistons and the outlet pressure valves make it possible to create channels with much lower pressure loss compared to the original design. In the original design, channel 1 in particular (see Figure 2) has a sharp corner of 135 degrees, which resulted in a large pressure drop.

The flow model used in this study is very simple and is not intended to give an exact answer for the pressure loss in the system, but rather be good enough to compare alternative designs. Compared to the pressure drop measured and calculated by [Kärnell et al. \(2018\)](#), the model in this study is judged to perform well enough to be used to compare different designs, as the obtained pressure losses with the proposed model are approximately 10% from the validated measured values.

The results in this study show a reduction in pressure loss of 45% up to 85%, which is similar to other cases found in the literature for hydraulic manifolds which are redesigned to be manufactured by AM, see ([Alshare et al., 2019](#); [Chekurov and Lantela, 2017](#); [Cooper et al., 2012](#)). The weight reduction of 35% is also in line with other studies such as ([Alshare et al., 2019](#); [Pavel et al., 2018](#); [Semini et al., 2015](#); [Smelov et al., 2020](#)). Furthermore, the reduction in part and sealing count has the potential to lower the cost and reduce leakage in the system.

To create even larger improvements in pump performance, the overall design could be reconsidered, and larger changes implemented. If the inlet and outlet are redesigned simultaneously, a larger design space can be achieved, and more innovative solutions can most likely be identified. An idea in this study was to place all the outside check valves in the same place (like the position of the ones for outlet 2 in Figure 1), which would make it possible to optimize the outlet distance and curvature possible for reduced pressure loss. This solution would potentially also reduce the mass and part count even more than the current new solution. The inlet constrains the amount of space available and makes it impossible to fit this kind of solution (and keep a thick enough wall). This could possibly be solved by a small redesign of the inlet or by changing the material to one with better material properties (e.g., Ti64, or some other super-alloy).

Another possibility is to create static integrated check valves. [Wits et al. \(2013\)](#) show that this works in a micro context, but the question of whether it works for larger applications remains unclear. This kind of solution would make it possible to manufacture the pump as one large unit with the potential to optimize the internal channels, but also to create a more compact pump.

Overall, some limitations of the study need to be addressed. The largest limitation, the pressure drop model, is already discussed above. The pressure drop in AM manufactured channels is difficult to count since the surface roughness of the channels is dependent on geometry, manufacturing setup, material, and postprocessing. The surface roughness also influences the fatigue life of the components, which is not verified in the present study. Moreover, roughness or small defects in the material surface can endanger the structural life of the component. Since the design contains internal channels, it is also difficult to inspect whether any errors have occurred during manufacturing. This specific problem can be solved with the use of an in-situ monitoring system that inspects each layer during manufacturing ([Chua et al., 2017](#)).

4.2. Future directions

While the literature study shows that AM can improve the performance of various fluid applications, the redesign work in this paper shows that similar improvements can be achieved with relatively small changes in hydraulic pumps as well. The recommendations for future directions can be split into academic potential and industrial application. Academic potential includes making the manufacturing cost-efficient, including the full process from design to postprocessing. A huge factor in this is the material, with the material selection, development, and verification process in need of improvement. Another factor which has a major impact on the cost is the design. During this process, optimization of multiple disciplines needs to be included to not only optimize the functionality of the pump, but the

manufacturing and postprocessing cost as well. An academic challenge is the development of advanced computational simulation models which can properly predict losses in AM manufactured channels. The main industrial take-away from this work is that it shows that AM has been investigated enough for it to be implemented in industry. However, the full economic aspect of hydraulic manufactured pumps needs to be further investigated based on specific application cases. Reduction in assembly costs and the number of parts can sometime compensate, by reducing assembly operations. Otherwise, further value can be added to the component if mass customization is applied to specially adapt the pump for specific cases. Mass customization is maybe not a traditional approach in hydraulic pumps, but this option would make it possible to create pumps which are better adapted to the use-case. Together with smart control, a user-adapted pump could be designed to be optimal for the specific use-case. For some applications, the improved functionality in terms of pump efficiency, mass reduction, and total component volume can add considerable value assuring that AM is a competitive manufacturing method.

5. Conclusions

This paper presents a review of existing applications of AM manufacturing in fluid power applications (study goal 1). Many applications of AM have been examined, e.g. for heat exchangers and hydraulic manifolds, but it is concluded that AM manufactured hydraulic pumps are not an extensively investigated area of research. However, various applications of hydraulic pipes, manifolds, engines, and others show that AM can improve functionality in terms of efficiency, pressure loss, and mass reduction. By offering a novel redesign of a hydraulic pump, this work contributes the insight that high pressure hydraulic pumps are feasible to manufacture with AM and similar advantages as in other applications can be found (study goal 2). The functional advantages gained in this work are a 45-80% reduction in pressure loss and a weight reduction of 35%. In addition, the part and sealing count is reduced by two, which reduces assembly costs and the risk of system leakage. These advantages were achieved with relatively small changes in the design showing the potential of application of AM on hydraulic pumps (study goal 3).

As a future project considering the studied pump, a more extensive redesign process could enable an even more innovative design with greater functional improvements. On a general scale, AM manufactured pumps can innovate pump design, not just through improved efficiency but also creating lighter, more compact, and integrated pumps. Manufacturing and testing the redesigned pump are a natural next step to validate its performance in realistic user settings.

References

- Alshare, A.A., Calzone, F., Muzzupappa, M., 2019. Hydraulic manifold design via additive manufacturing optimized with CFD and fluid-structure interaction simulations. *Rapid Prototyp. J.* <https://doi.org/10/gsndfw>
- Arie, M., Hymas, D., Singer, F., Shooshtari, A., Ohadi, M., 2020. An additively manufactured novel polymer composite heat exchanger for dry cooling applications. *Int. J. Heat Mass Transf.* 147. <https://doi.org/10/gs4tqn>
- Blakey-Milner, B., Gradl, P., Snedden, G., Brooks, M., Pitot, J., Lopez, E., et al., 2021. Metal additive manufacturing in aerospace: A review. *Mater. Des.* <https://doi.org/10/gmb3nb>
- Çengel, Y.A., Kanoglu, Mehmet., Cimbala, J.M., Turner, R.H., 2017. *Fundamentals of thermal-fluid sciences*, Fifth edition in SI units. ed. McGraw-Hill Education, Singapore.
- Chekurov, S., Lantela, T., 2017. Selective laser melted digital hydraulic valve system. *3D Print. Addit. Manuf.* <https://doi.org/10/gcr274>
- Chua, Z.Y., Ahn, I.H., Moon, S.K., 2017. Process monitoring and inspection systems in metal additive manufacturing: Status and applications. *Int. J. Precis. Eng. Manuf.-Green Technol.* <https://doi.org/10/gf839d>
- Cooper, D.E., Stanford, M., Kibble, K.A., Gibbons, G.J., 2012. Additive manufacturing for product improvement at Red Bull Technology. *Mater. Des.* <https://doi.org/10/gs4tqj>
- Frazier, W.E., 2014. Metal additive manufacturing: a review. *J. Mater. Eng. Perform.* 23, 1917–1928. <https://doi.org/10/gctr3s>
- Gao, W., Zhang, Y., Ramanujan, D., Ramani, K., Chen, Y., Williams, C.B., Wang, C.C., Shin, Y.C., Zhang, S., Zavattieri, P.D., 2015. The status, challenges, and future of additive manufacturing in engineering. *Comput.-Aided Des.* <https://doi.org/10/gctpcv>

- Gebisa, A.W., Lemu, H.G., 2018. Additive Manufacturing for the Manufacture of Gas Turbine Engine Components, in: Proceedings of ASME Turbo Expo 2018. <https://doi.org/10/gs4tqf>
- Ivantsyn, J., Ivantsynova, M., 2003. Hydrostatic pumps and motors: principles, design, performance, modelling, analysis, control and testing.
- Kärnell, S., Dellramico, A., Ericson, L., 2018. Simulation and validation of a wobble plate pump with a focus on check valve dynamics. 2018 Glob. Fluid Power Soc. PhD Symp. <https://doi.org/10.1109/GFPS.2018.8472400>
- Lei, T., Alexandersen, J., Lazarov, B.S., Wang, F., Haertel, J.H., De Angelis, et al., 2018. Investment casting and experimental testing of heat sinks designed by topology optimization. *Int. J. Heat Mass Transf.* <https://doi.org/10/gfq4sw>
- Lindermann, C., Jahnke, U., Moi, M., Koch, R., 2012. Analyzing product lifecycle costs for a better understanding of cost drivers in additive manufacturing, in: 2012 International Solid Freeform Fabrication Symposium. University of Texas at Austin.
- Liu, G., Zhang, J., Xu, B., 2019. Structure optimization for passages in hydraulic manifolds using metal additive manufacturing technology, in: 2019 IEEE 8th International Conference on Fluid Power and Mechatronics (FPM). <https://doi.org/10/gs4tqg>
- Matthiesen, G., Merget, D., Pietrzyk, T., Ziegler, S., Schleifenbaum, J.H., Schmitz, K., 2020. Design and experimental investigation of an additive manufactured compact drive. <https://doi.org/10/gs4tqs>
- Meisel, N.A., Woods, M.R., Simpson, T.W., Dickman, C.J., 2017. Redesigning a reaction control thruster for metal-based additive manufacturing. *J. Mech. Des.* <https://doi.org/10/gcqc8>
- Murrenhoff, H., 2014. Fundamentals of Fluid Power: Hydraulics, Volume 7, Fundamentals of fluid power. Shaker.
- Neubauer, B.C., Durfee, W.K., 2016. Simulation Based Design of a Pediatric-Sized Hydraulic Ankle-Foot Orthosis, in: Dynamic Systems and Control Conference. American Society of Mechanical Engineers. <https://doi.org/10/gs4tq5>
- Pavel, R., Leonid, R., Ivan, S., 2018. Analysis of hydraulic units manufactured by powder bed fusion, in: 2018 Global Fluid Power Society PhD Symposium (GFPS). <https://doi.org/10/gs4tqp>
- Robinson, A., Kempers, R., Colenbrander, J., Bushnell, N., Chen, R., 2018. A single phase hybrid micro heat sink using impinging micro-jet arrays and microchannels. *Appl. Therm. Eng.* <https://doi.org/10/gs4tqh>
- Roper, C.S., Schubert, R.C., Maloney, K.J., Page, D., Ro, C.J., Yang, S.S., Jacobsen, A.J., 2015. Scalable 3D bicontinuous fluid networks: polymer heat exchangers toward artificial organs. *Adv. Mater.* <https://doi.org/10/f26dm5>
- Semini, C., Goldsmith, J., Manfredi, D., Calignano, F., Ambrosio, E.P., Pakkanen, J., Caldwell, D.G., 2015. Additive manufacturing for agile legged robots with hydraulic actuation, in: 2015 International Conference on Advanced Robotics (ICAR). <https://doi.org/10/gs4tqm>
- Smelov, V.G., Kokareva, V.V., Agapovichev, A.V., 2020. A Review of Hydraulic and Pneumatic Aggregates Manufacturing By Additive Technologies, in: 2020 International Conference on Dynamics and Vibroacoustics of Machines (DVM). <https://doi.org/10/gs4tqd>
- SS-EN ISO/ASTM 52900:2017, 2017.
- Vasco, J.C., 2021. Additive manufacturing for the automotive industry, in: Additive Manufacturing. Elsevier, pp. 505–530. <https://doi.org/10.1016/B978-0-12-818411-0.00010-0>
- Wiberg, A., Persson, J., Ölvander, J., 2019. Design for additive manufacturing—a review of available design methods and software. *Rapid Prototyp. J.* 25, 1080–1094. <https://doi.org/10/gjbhrp>
- Wiberg, A., Persson, J.A., Ölvander, J., 2023. A Design Automation Framework Supporting Design for Additive Manufacturing, in: IDETC and CIE Conference. ASME, <https://doi.org/10/gthsxz>
- Wits, W.W., Weitkamp, S.J., van Es, J., 2013. Metal additive manufacturing of a high-pressure micro-pump. *Procedia Cirp* 7. <https://doi.org/10/gs4tq3>
- Yakout, M., Elbestawi, M., Veldhuis, S.C., 2019. Density and mechanical properties in selective laser melting of Invar 36 and stainless steel 316L. *J. Mater. Process. Technol.* 266, 397–420. <https://doi.org/10/ggmjw5>
- Yang, S., Tang, Y., Zhao, Y.F., 2015. A new part consolidation method to embrace the design freedom of additive manufacturing. *J. Manuf. Process.* <https://doi.org/10/f76dp2>
- Yang, S., Zhao, Y.F., 2015. Additive manufacturing-enabled design theory and methodology: a critical review. *Int. J. Adv. Manuf. Technol.* <https://doi.org/10/gjkm6x>