

# Functional Collaborative Remote Microscopy: Inter-Continental Atomic Resolution Imaging

J. M. Perkins,\* D. A. Blom,\*\* D. W. McComb,\* and L. F. Allard\*\*

\*Department of Materials, Imperial College London, UK

\*\* Materials Science and Technology Division, Oak Ridge National Laboratory, Oak Ridge, TN

\*\*\*University of South Carolina, Columbia, SC  
j.m.perkins@imperial.ac.uk

In recent years the development of remote microscopy, specifically in electron microscopes, has begun to emerge as a useful research tool rather than simply an educational or teaching aid. Scientists have long been able to work collaboratively at a distance; however, it is often in terms of receiving data or sending some instructions where there may be a delay in receipt of the information. When defining remote control it is important to note that electron microscopy requires instantaneous control and receipt of the feedback (in most cases via images on a screen). Without real-time control it is impossible to conduct high resolution imaging and analysis work. In terms of electron microscopy, there are several reasons for conducting experiments remotely: With sub-Ångström aberration-corrected scanning transmission electron microscopes, the environment within which the microscope itself sits is of utmost importance. By removing the user, the room will be free from 'human' sources of vibration and temperature variation. Secondly, instruments operating in a clean room environment may be controlled without the user needing to be in the same area. Finally, the microscope may be used more efficiently if access were available at all times and from multiple locations. True remote operation would allow a user to 'log-in' from a completely separate workstation, which enables collaborative work without the need to travel.<sup>[1]</sup>



1: a) ORNL JEOL 2200FS at the HTML, b) the 'local' remote control of the instrument.

Modern transmission and scanning electron microscopes are almost fully computer controlled and it is this that allows the most basic of 'remote' experiences whereby the user is simply controlling a PC next to the instrument itself with all the data transmission occurring over either a network or directly from a control board in the PC. Removing the user from the room in which the microscope sits is therefore relatively straightforward, assuming an appropriate network and the ability to view the correct controls (and image!) is available. When it comes to any sort of long distance remote

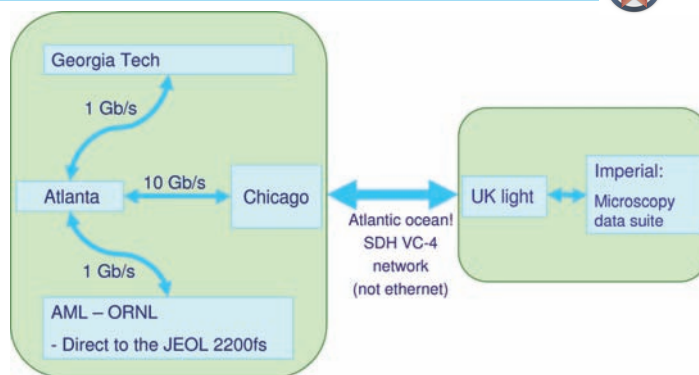

2: Schematic of the AtlanTICC alliance Lambda rail network

microscopy, the network and speed of connection becomes the limiting factor<sup>[2]</sup>. Previous remote microscopy collaborations have been limited by the speed of connection and therefore both the image refresh rate and/or the number of available functions that may be controlled has been limited.<sup>[3]</sup>

Imperial College London, Oak Ridge National Laboratory, and the Georgia Institute of Technology have implemented the first phase of a 'Global lab' under the umbrella of the AtlantICC Alliance<sup>[4]</sup>. By using a *dedicated* high bandwidth, low latency network (UKLight/Lambda rail<sup>[4]</sup>) it has been possible to control the JEOL 2200FS aberration-corrected scanning transmission electron microscope (STEM) at ORNL from the electron microscopy lab in the department of materials, Imperial College London<sup>[5]</sup>. Imperial College has the first monochromated FEI Titan 80-300 in the UK with a Gatan Tridiem spectrometer. The Titan is primarily used for high resolution electron energy loss spectroscopy (HREELS). The JEOL instrument is Cs (probe) corrected and therefore perfect for atomic resolution STEM imaging, this means the two microscopes complement each other very well. The 2200FS is housed in ORNL's Advanced Microscopy Laboratory, a facility that provides ultimate environmental control necessary for a number of instruments capable of sub-Ångström resolution to routinely achieve their specification capabilities. The microscope sits in a controlled environment with 'local' remote operation via the direct link to a PC in the operator room. Figure 1 shows the ORNL instrument seen through the window of the control room in the HTML building. The enabling technology is the network, a schematic of which is shown in Fig. 2. The Lambda rail network uses a dedicated band of wavelengths that do not receive any traffic other than that to/from the microscope or controller. The low latency optical fibre network allows incredibly quick data transmission connected by Ethernet switches. This provides a point-to-point connection with network speeds up to 10Gbs. This allows not only real time control of the microscope itself but several streams of high definition audio/visual data. It is the combination of the remote control with the collaborative aspect that has enhanced the remote control experience.

At Imperial College, the computer has a remote version of the JEOL control panel with multi-function knobs and buttons (Sirius). The Sirius control panel fulfils all the functions of the local control panel, this enables the "feel" of the microscope to be transferred to the remote user. Figure 3 is a view of the operation of the 2200FS via the remote panel, from the Imperial laboratory. The JEOL Sirius remote operation software (previously demonstrated on a wireless system within the US<sup>[6][7]</sup>) has been tested over the transatlantic link and works with zero appreciable delay. UltraVNC remote



# Value and Excellence in SEMs

## VEGA Scanning Electron Microscopes

Fully automated PC-controlled SEMs designed for a multi-user environment.

High performance 4-lens optics provides high resolution, high depth of focus, extremely large field of view as well as optimum working conditions for any application.

High working vacuum and variable pressure operation up to 2000 Pa.

Original patented Low Vacuum Secondary Detector for true secondary electron imaging under low vacuum.

Full range of precision-engineered specimen chambers and stages.

Sophisticated yet easy-to-use software for microscope control and image processing & evaluation.

Network operations with built-in remote control and diagnostics.

3D surface reconstruction using 3D beam technology.



Fisheye Mode  
The right tool for low magnification imaging.



**Tescan** USA

tel. 724-772-7433  
[www.tescan-usa.com](http://www.tescan-usa.com)



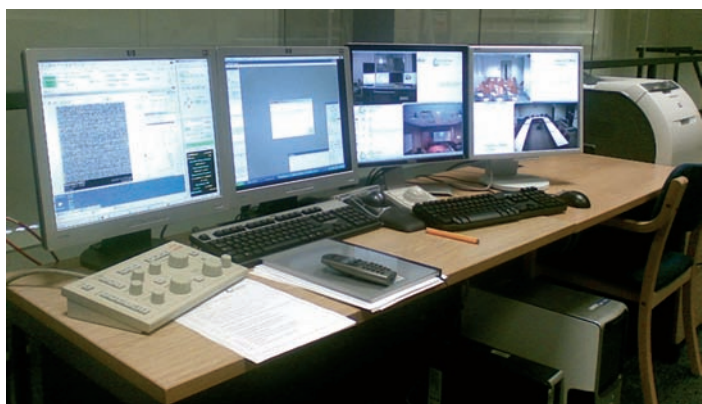

3: UK remote control desk. The JEOL Sirius control panel and remote control PC. Two monitors display the microscope control software and two monitors display the high definition AV streams. (copyright: Materials World magazine of the IOM Communications.)

desktop connection software<sup>[8]</sup> was used to provide multiple views of the two local microscope control PCs on the remote operation PC. These provided not only a real-time view of the screen but full control, without removing control from the local operator. Both the microscope control pc and the support pc (running the aberration corrector and STEM scanning software) can be displayed on the remote pc monitors. All relevant displays are available to the remote operator and therefore all functions/controls available to the 'local' user are present at the remote station. Figure 4 is a screen shot of the remote control PC desktop showing the microscope control software, the Sirius remote control application and Digital Micrograph (Gatan, Inc.). An additional workstation is connected to the Lambda rail in both labs in order to provide the high-definition audio/visual stream.

The initial phase of use has proved that the system is not only capable of full remote control of the microscope (except sample loading and filling of the anti-contamination traps), but also, with the addition of the high-definition audio-visual system, a new capability for collaborative experimentation. The use of the specialist network enables a real-time, zero delay image of what is seen locally

in the microscopy control room, which means that 'non-local' support is required other than for routine tasks. It has been mentioned previously that listening for things like valves opening and closing, pumps running up *etc.* is an important part of the microscopy experience, however, this is not relevant in this case as the 'local' user operates the instrument from outside the microscope room anyway. Furthermore, if more input is required, there is enough bandwidth to add more video or audio streams to add to the experience. Figure 5 is a plot of network traffic over the "lambda rail" to the Imperial lab during a demonstration event. It shows up to 130Mbs of traffic, far beyond the capabilities of any home or business network. The largest usage of bandwidth occurred when four AV streams and the microscope were being used simultaneously. There was zero slowdown and a continuous uninterrupted connection throughout the demonstration event.

The collaborative aspect of the Imperial-ORNL setup surpassed our expectations. When working on a sample with both the 'local' and 'remote' scientists we were able to both control the microscope and easily identify regions of interest, take turns in the acquisition and more efficiently make use of the time. The video stream uses 30Mbs of bandwidth in order to provide a high quality feed. This means that the 'local' cameras can be positioned to show anything from LED displays on the vacuum cabinet to the 'local' control PC screens themselves. The potential for collaborative work is almost limitless because multiple users can log in as long as they have the appropriate Lambda rail connection. Thus, the microscope user can interact with an external site while operating the microscope itself, or indeed demonstrate an experiment to a greater number of people than could otherwise be accommodated in the lab.

The UK-USA connection has the additional advantage of uninterrupted experimentation utilizing the time-zone difference between Tennessee and London. The Lambda rail is not limited to the remote microscopy project and has been used for other areas of research within the framework of the AtlanTICC Alliance project. Examples include video conferencing, sharing of data, access to supercomputer clusters and other instrumentation.

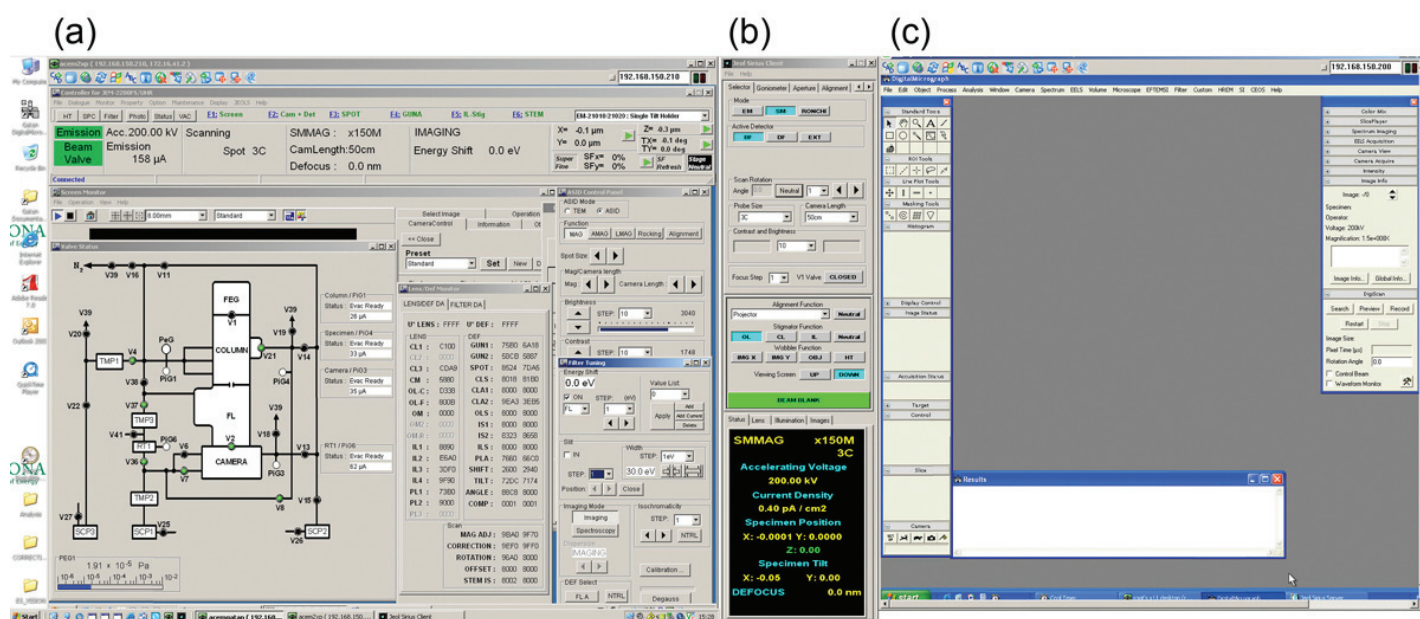

4: Screenshot of remote control PC desktop; a) microscope control software, b) JEOL SIRIUS, the application that runs the trackball and FasTEM control panel, c) Gatan Digital Micrograph for data acquisition.

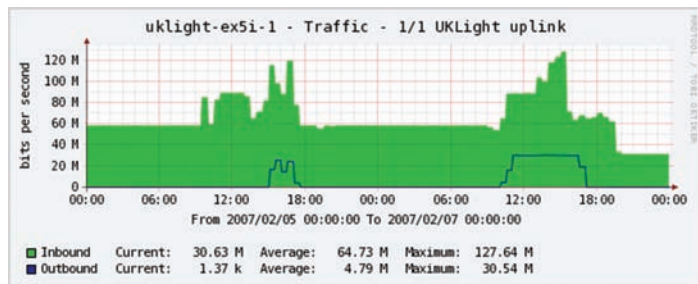

5: Plot of streaming data for both incoming and outgoing connections at the Imperial side of the Lambda rail connection. The solid green represents incoming and the blue line represents outgoing traffic.

The next phase of the project is to add the Imperial College FEI Titan instrument to the network. It is currently operating as a stand-alone instrument with an optional 'local' remote connection. This 'local' remote control allows the user to exit the room after loading the sample and take full control of the microscope (Figure 6). Monochromated HRSTEM-EELS and spectrum imaging require a highly stable environment to minimise sample drift and/or fluctuations in the stability of the electron energy loss spectrum.



6: "Local" remote control of the Imperial College Titan. This workstation is connected to the microscope support PC via an optical fibre connection through to the microscope room.

**Acknowledgements:** This project was funded as part of the AtlanTICC Alliance network collaboration. The teams have been led by Brian Savory (GT), Ian Gould (Imperial) and Bill Wing (ORNL). Thanks also to Mark Forster (Imperial) for additional help with the Imperial Lambda rail setup. ■

### References

- [1] A. van Balen., C. L. Morgan. Details from a distance: Seeing Angstroms at 10,000 Kilometers. Proceedings INet2000, Yokohama, Japan
- [2] K. Yoshida et al. Design of a Remote Operation System for Trans-Pacific Microscopy via International Advance Networks. Journal of Electron Microscopy. 51 (2002) S253-S257.
- [3] O'Keefe. M. A., B. Parvin. Experiences with remote electron microscopy. Proceedings ICEM, Durban, South Africa, 2002.
- [4] <http://www.atlanticcallyiance.org/>
- [5] J. M. Perkins et al. Functional remote microscopy via the AtlanTICC alliance network. to appear in Proceedings Microscopy and Microanalysis 2007 (Microscopy and Microanalysis, volume 13, Cambridge University Press (2007))
- [6] <http://www.nlr.net/benefits/>
- [7] R. Nelson., Jeol untethers TEM, Test and measurement world. 4 (2006)
- [8] <http://ultravnc.sourceforge.net/>



# MRS-5

We are ISO-9000 certified and ISO-17025 accredited  
**Microscopy Calibration Standard**  
 Now you can calibrate from 1,000X to 1,000,000X!

This is our fourth generation, traceable, magnification reference standard for all types (SEM, FESEM, Optical, STM, AFM, etc.) of microscopy. The MRS-5 has multiple X and Y pitch patterns ranging from 80nm ( $\pm 1$ nm) to 2 $\mu$ m and 3 bar targets from 80nm to 3 $\mu$ m. There is also a STM test pattern.

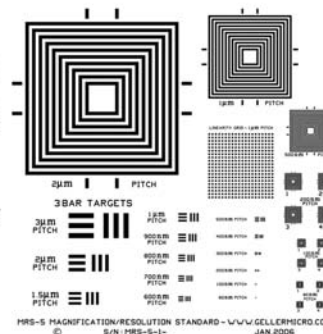

Free web resource guide!



**GELLER  
 MICROANALYTICAL  
 LABORATORY, Inc.**

426e Boston St., Topsfield, Ma 01983  
[www.gellermicro.com](http://www.gellermicro.com)

## Custom Microscopy Supplies From M. E. Taylor Engineering, Inc.

- ◆ **SEM Light Pipe Scintillators**, styles for Leo & Cambridge SEMS and custom products
- ◆ **Scintillators:** ITO Gold, Phosphor, YAG and YAP from \$89
- ◆ **Recoating of Light Pipes** from \$150
- ◆ **Conductive Adhesive Products**  
 Silver paint, pens and epoxy  
 Carbon paint, tape and tabs
- ◆ **ProScope and Dino Microscopes** and accessories

**Phone (301) 774-6246**

See our products on the Web @  
[www.semsupplies.com](http://www.semsupplies.com)