

ORBITAL SELECTION EFFECTS IN THE PALOMAR-LEIDEN ASTEROID SURVEY

L. KRESÁK

*Astronomical Institute of the Slovak Academy of Sciences
Bratislava, Czechoslovakia*

The selection effects appearing in the list of minor planet orbits based on the Palomar-Leiden survey are discussed. In addition to purely geometrical effects produced by the limitation of the survey in time and position, the arrangement of orbits by perturbations plays an important role. Some apparent differences from the orbits of brighter asteroids can be easily explained. As an example of the operation of the selection effects, it is shown that the asteroidal jetstream believed to exist within the Nysa family is spurious.

The results of the Palomar-Leiden survey (PLS) (van Houten et al., 1970) will undoubtedly be, for years to come, the basic reference on the orbits of the faintest asteroids detectable by the present techniques. The PLS results provide an excellent counterpart to the list of numbered minor planets in the *Ephemeris* nearly as extensive and extended in the mass scale about three orders of magnitude lower. Although the accuracy of the orbits is insufficient for a recovery, it is quite satisfactory for statistical purposes. The only drawback is the inevitable limitation of the survey in time and position, which introduces selection effects rather different from those applying to the catalog of numbered asteroids. A correct appraisal of these effects is a prerequisite of any comparison of the two samples.

The important selection effect coming from the relation between absolute magnitude, mean distance, and mean opposition magnitude is common to both samples and will not be considered here. Selection effects special for PLS can be divided into two groups: those produced by the limitation of the survey in longitude (or time) and those produced by the limitation in latitude (or declination). Each of these consists of two components: one independent of the particular longitude interval covered by the survey and the other dependent on it.

In general, the former component produces primary effects, some of which have already been cited by the authors of the survey. Nevertheless, in some respects the latter component is also very significant, especially in the particular position of the survey areas chosen for PLS. The plates were taken, as in the previous McDonald survey, near the vernal equinox where a small

number of background stars makes the searches more efficient than in opposition areas of lower galactic latitude. By coincidence, this is at the same time the region of maximum clustering of asteroid perihelia due to the perturbational alinement of their lines of apsides to that of Jupiter. Moreover, the survey area is situated about midway between Jupiter's nodes on the ecliptic, approximately in the same longitude as the poles of the precessional motion of the orbital planes produced by secular perturbations. Plates centered on the ecliptic deviate here about 1° north from the great circle of the central plane of the asteroid belt. This deviation is not negligible compared with the 6° half-width of the strip covered by the survey.

In the following analysis of osculating elements, only first- and second-class orbits (1119 in number, $Q = 1$ and $Q = 2$ in table 7 of PLS) will be used. Where proper elements are introduced, the data are restricted to the first-class orbits only (967 asteroids of table 9 in PLS).

THE EFFECTS OF LIMITATION IN LONGITUDE

Because the detectability of an asteroid depends on its apparent brightness at the time of exposure, an immediate consequence of a time-limited survey is a preference for those asteroids that happen to be near their perihelia. This preference for mean anomalies near $M \cong 0^\circ$, clearly borne out by the PLS catalog, should be reflected in the orbital elements as a maximum occurrence of the perihelion longitude $\pi \cong \lambda$, or about 0° to 30° , and a minimum at $\pi \cong \lambda + 180^\circ$, or about 180° to 210° . The strength of this effect obviously depends on eccentricity e ; it vanishes as e approaches zero.

The observed distribution of the perihelion longitudes of the PLS asteroids ($Q = 1$ and $Q = 2$) is shown in figure 1. The asymmetry is pronounced indeed, with about four times as many asteroids recorded near their perihelia as near their aphelia. As expected, the asymmetry decreases with decreasing eccentricity to a rather uniform distribution at $e < 0.10$. The only unexpected feature is the double maximum, with two lobes displaced about 30° to 40° on either side of the expected position. The reason for this duplicity is not quite clear. It may be noted that the errors in ω and π due to measuring errors would also tend to disperse π to both sides of $\pi = \lambda$ and $\pi = \lambda + 180^\circ$. The importance of this effect should increase with decreasing e , in accordance with the edged outline of the distribution at $e < 0.15$. However, the angle of displacement appears too large for this interpretation as far as first- and second-class orbits are concerned.

The selection effect of a time-limited survey on perihelion longitudes can be eliminated if the actual plate limit (in apparent magnitude) is replaced by an artificial limit of mean opposition magnitude, up to which the search is essentially complete. Unfortunately, this considerably reduces the number of orbits available.

From figure 1(b) we see that asteroids with $m_0 > 19.0$ are those that contribute substantially to the asymmetry. Some traces of the effect remain

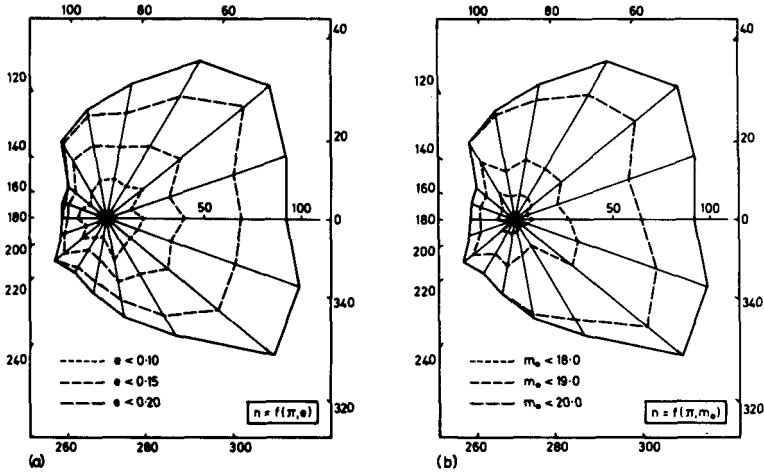

Figure 1.—Distribution of PLS asteroids in perihelion longitude π . (a) For different upper limits of eccentricity e . (b) For mean opposition magnitude m_0 .

even at $m_0 < 19.0$. At $m_0 < 18.0$ some prevalence of $\pi \cong 90^\circ$ over $\pi \cong 270^\circ$ is indicated; however, the number of asteroids as bright as this is too small to justify any statistical conclusions.

One of the direct consequences of this selection effect is an apparent correlation between π and e , to be distinguished from the virtual correlation produced by the alinement of the lines of apsides by planetary perturbations. Orientation $\pi \cong \lambda$ prefers the detection of high-eccentricity orbits; orientation $\pi \cong \lambda + 180^\circ$ prefers that of low-eccentricity ones. This effect is shown in figure 2, with characteristic values of eccentricities plotted in a polar diagram of perihelion longitudes.

The situation is complicated by the fact that the distribution in eccentricity is at the same time affected by the limitation of the survey in latitude. As already pointed out by van Houten et al. (1970), this limitation tends to eliminate the orbits of high inclinations, which are mostly associated with high eccentricities. On the other hand, the orbits closely alined to Jupiter's line of apsides, which are preferred in PLS by $\pi \cong \lambda$, are also generally above average in eccentricity. Thus the observed distribution of eccentricities in PLS is determined by the interplay of three fundamentally different effects; and without separating them one cannot compare the data with those on the numbered, brighter asteroids. One can only conclude that there is no evidence of any significant difference. At the level of median values, where the selection effects are not extraordinarily prominent, the resemblance of the two samples is very close: $e_{0.50} = 0.144$ for the numbered asteroids and $e_{0.50} = 0.147$ for the PLS. As we proceed to the high-eccentricity tail of the distribution, the elimination of the asteroids with high-eccentricity, high-inclination orbits by

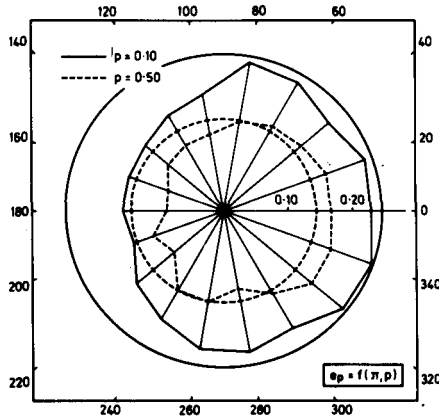

Figure 2.—Medians ($p = 0.50$) and limiting values of 10 percent occurrence ($p = 0.10$) of eccentricities of PLS asteroids plotted as a function of perihelion longitude π . The circles indicate comparative values obtained irrespectively of π from 1745 numbered asteroids.

the latitude effect becomes decisive and the proportion drops more rapidly in PLS than among the numbered asteroids. At the beginning of the 10 percent distribution tail, for which the values of $e_{0.10}$ are plotted in figure 2, the PLS data do not surpass the eccentricity $e_{0.10} = 0.247$ of the numbered asteroids even at $\pi = \lambda$.

The selection effects on the osculating perihelion longitude π obviously are reflected also in the corresponding proper element β , the difference between β and π being normally about 10° , and only rarely exceeding 30° . Thus the longitude limitation affects also the observed structure of the asteroid families in the β/γ plane.

As a result of the relationship between the proper elements and the osculating elements, a random distribution in β implies a prevalence of certain values of π . The resulting direction of maximum concentration of the osculating perihelia depends on the semimajor axis a . In the outer part of the asteroid belt a close alinement to Jupiter's line of apsides takes place. In the inner part, below $a = 2.64$, the deviation amounts to a few tens of degrees in the retrograde direction, but the maximum concentration is still not far from the PLS area. The elements π_0 , e_0 corresponding to an orbit of zero proper eccentricity are given in table I for several values of a , which are medians from different asteroid samples. The sets of elements denoted "PLS" and "numbered asteroids" are composed of the median elements of each of these catalogs; the "center of the belt" is an ellipse passing through the median heliocentric distances of the 333 largest asteroids ($g < 10.0$) in different longitudes (Kresák, 1967). All asteroid families for which more than 20 members have been identified in PLS are included. The values of induced

TABLE I.—Orbital Elements

Asteroid samples	Elements							
	a	e	i	π_0	e_0	Ω_0	i_0	
PLS	2.591	0.147	4° 15	350° ±	0.031±	92°	1° 03	
Numbered asteroids	2.756	.144	8.40	6	.038	95	1.11	
Center of the belt	2.850	.040	1.60	6	.037	96	1.15	
Asteroid families (PLS):								
1 Themis	3.146	.163	1.87	9	.038	98	1.22	
2 Eos	3.018	.073	9.50	8	.037	97	1.19	
3 Coronis	2.885	.056	2.52	6	.037	96	1.16	
6 Flora	2.231	.158	4.05	338	.048	57	.64	
30 Vesta	2.311	.113	6.57	344	.042	75	.76	
31 Michela	2.389	.187	1.42	349	.038	83	.86	
32 Nysa	2.391	.187	2.41	349	.038	83	.86	
33 Io	2.641	.182	12.76	0±	.035±	93	1.06	
34 Medea	3.163	.135	4.62	9	.038	98	1.22	

oscillations were interpolated from the table of Brouwer and Clemence (1961). The weighted means for the PLS asteroids are $\pi_0 = 354^\circ$ and $e_0 = 0.038$.

It is evident that the degree of alinement to Jupiter's line of apsides is a function of the distribution in semimajor axes. The appreciable differences Δa and $\Delta\pi_0$ between PLS and the numbered asteroids may be due to a relative lack of faint asteroids at $a = 3.10$ to 3.20 , as suggested by van Houten et al. (1970). However, the actual difference is likely to be smaller because the selection of faint asteroids near their perihelia is more efficient for smaller semimajor axes. On the other hand, the ecliptical longitude of the survey plates slightly favors asteroids of greater semimajor axes. Also the elimination of high-inclination objects by the limitation of PLS in latitude (to be discussed in the next section) may affect this difference, especially because of the tendency of asteroids to group into families with discrete values of proper inclination.

An important consequence of the radial asymmetry of the asteroid belt is that the distribution in geocentric distance of the asteroids located, and hence also the gain of the survey, varies with the ecliptical longitude covered. In the case of PLS, including Jupiter's perihelion, the conditions are optimum. The differences between the perihelion opposition magnitude m_p , the aphelion opposition magnitude m_A , and the mean opposition magnitude m_0 are expressed by

$$m_p - m_0 = 5 \log(1 - e) - 5 \log(a - 1) + 2.5 \log[1 + a^2(1 - e)^2 - 2a(1 - e)(1 - \sin^2 i \sin^2 \omega)^{1/2}] \quad (1)$$

$$m_A - m_0 = 5 \log(1 + e) - 5 \log(a + 1) + 2.5 \log[1 + a^2(1 + e)^2 - 2a(1 + e)(1 - \sin^2 i \sin^2 \omega)^{1/2}] \quad (2)$$

for statistical purposes we can insert $\sin^2 \omega = 0.5$.

Assuming the magnitude distribution found by van Houten et al. (1970),

$$\log N(m_0) = 0.39m_0 + \text{const} \quad (3)$$

we can write the ratio ρ_1 of the number of asteroids observable at a perihelion opposition to that observable at an aphelion opposition as

$$\log \rho_1 = 0.39(m_A - m_p) \quad (4)$$

The actual relative numbers of asteroids detected in a survey will differ from this, both because of the Law of Areas maintaining the asteroids for a longer time in the remote part of their orbits and because of the variation of the effective field of view with distance. Neglecting the trailing effect, we have

$$\rho_2 = \frac{a - 1 - ea}{a - 1 + ea} \rho_1 \quad (5)$$

for the relative numbers of asteroids observable in the longitude of perihelion and aphelion, respectively, and

$$\rho_3 = \left(\frac{a - 1 - ea}{a - 1 + ea} \right)^2 \frac{1 + e}{1 - e} \rho_1 \tag{6}$$

for the relative gain in a survey restricted to a narrow strip along the ecliptic.

The values of $m_P - m_0$, $m_A - m_0$, ρ_1 , ρ_2 , and ρ_3 for selected types of orbits are listed in table II. The elements used for the computation are the same as in table I.

It must be emphasized that the validity of equation (4) for asteroid families is rather questionable; it appears probable that this distribution law holds only for the asteroidal "sporadic background." Nevertheless, in relatively narrow intervals of m_0 involved in the selection effects, it can be adopted as a rough approximation to show, at least, what bias in the observed structure of individual families can be expected.

The data of the third line of table II show the effect of opposition longitude on the total number of asteroids detected in PLS. If the alinement of the lines of apsides of faint asteroids is exactly the same as that of the bright ones, a repetition of the survey under equal conditions, but near the autumnal equinox instead of the vernal equinox, should reveal a total number of asteroids reduced by a factor of 1.26 (i.e., to 79 percent). Inversely, this repetition would yield decisive information on the actual degree of alinement, and would make it possible to determine the actual distribution of eccentricities from the differences in the relation between e and π (fig. 2) against that determined from PLS.

THE EFFECTS OF LIMITATION IN LATITUDE

The principal effects of this type, a strong preference for nodal longitudes $\Omega = \lambda \cong 0^\circ$ and $\Omega = \lambda + 180^\circ \cong 180^\circ$ and the elimination of orbits of higher inclination at other nodal longitudes, have already been pointed out by the authors of the PLS. The pronounced selection in Ω , as well as the gradual diminution of the effect with inclination approaching 0° , is clearly shown in figure 3(a). One important consequence that has not been considered is the transformation of this effect into the system of proper elements.

The poles of the precessional motion of most asteroidal orbits are inclined about 1° from the pole of the ecliptic in the direction north pole \rightarrow vernal equinox \rightarrow south pole \rightarrow autumnal equinox. The weighted mean position of the plane perpendicular to this axis is defined by $\Omega = 88^\circ$ and $i_0 = 0.97^\circ$ for the PLS asteroids. The elements Ω_0 , i_0 applying to different orbits, as determined from the median values of a using the table of Brouwer and Clemence (1961), are given in the last two columns of table I. The position of the nodes approximately 90° from the area of the PLS makes the data rather sensitive to this deviation. Although the distribution of osculating nodes Ω is essentially

TABLE II.—*Distribution Characteristics*

Asteroid samples	$m_P - m_0$	$m_A - m_0$	ρ_1	ρ_2	ρ_3
PLS	-0.94	0.77	4.61	2.83	2.34
Numbered asteroids	-.88	.74	4.29	2.71	2.29
Center of the belt	-.23	.22	1.49	1.32	1.26
Asteroid families (PLS):					
1 Themis	-.98	.79	4.92	3.02	2.58
2 Eos	-.40	.39	2.04	1.64	1.52
3 Coronis	-.32	.30	1.74	1.46	1.38
6 Flora	-1.10	.87	5.88	3.26	2.49
30 Vesta	-.73	.64	3.41	2.28	1.91
31 Michela	-1.29	.98	7.71	3.96	2.97
32 Nyssa	-1.29	.98	7.70	3.95	2.96
33 Io	-1.15	.94	6.54	3.58	2.83
34 Medea	-.79	.67	3.72	2.49	2.19

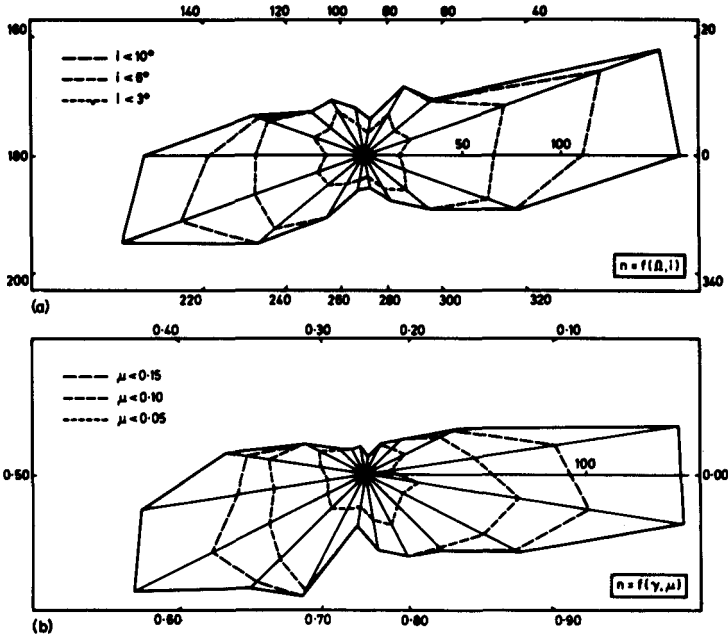

Figure 3.—Distribution of PLS asteroids. (a) In nodal longitude Ω for different upper limits of inclination i . (b) For the proper elements γ, μ .

symmetrical with respect to the ecliptical longitude of the survey area (fig. 3(a)), the distribution of proper nodes γ exhibits a displacement of the two maxima toward $\gamma = 0.75$. The first minimum near $\gamma = 0.25$ is considerably deeper (by a factor of 3) than the second minimum near $\gamma = 0.75$ (fig. 3(b)). In addition to the selection in the longitude of the proper perihelion, this effect can appreciably bias the observed structure of the asteroid families in the β/γ diagram, the occurrence of Brouwer's (1951) groups or Alfvén's (1969) jetstreams.

Although the distribution of the PLS asteroids in inclination is strongly affected by the limitation of the survey in declination, the median value of i being only one-half that found for the numbered asteroids (table I), some dependable information can be obtained even in this respect when selection effects are properly taken into account. It is obvious that the observed characteristic values of i (such as the median $i_{0.50}$ or the limit of the 10 percent occurrence tail $i_{0.10}$) should approach the correct value as Ω approaches, from both sides, $\Omega = \lambda$ and $\Omega = \lambda + 180^\circ$. Because of the duration of the survey, which tended to eliminate objects of higher inclination from the first- and second-class sample (positions from two dark-of-the-Moon periods) even if they were located near their nodes, the correct value should not be reached even at $\Omega = \lambda$ and $\Omega = \lambda + 180^\circ$. This is precisely what is shown in figure 4 where the whole polar diagrams of $i_{0.50}$ and $i_{0.10}$ lie within the

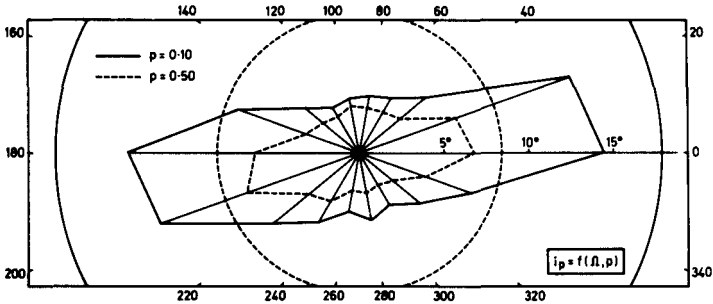

Figure 4.—Medians ($p = 0.50$) and limiting values of 10 percent occurrence ($p = 0.10$) of inclinations of PLS asteroids plotted as a function of nodal longitude Ω . The circles indicate comparative values obtained irrespectively of Ω from 1745 numbered asteroids.

circumference applying to the numbered asteroids, with a pronounced symmetry and extremes of about 80 percent of the latter. It is concluded that, with all probability, the actual distribution of faint asteroids in inclination does not differ at all from that of the bright objects.

The fact that the plane of greatest concentration of the asteroids, indicated by the proper elements, passed about 1° south of the center of the declination strip covered by the survey has some effect on the determination of the density gradient perpendicular to the central plane of the belt. However, because the displacement is only about one-tenth the distance at which the density drops to one-half, and the maximum is not very sharp (van Houten et al., 1970), this effect can be safely neglected in comparison with random sampling errors.

AN APPLICATION TO THE STRUCTURE OF ASTEROID FAMILIES

To illustrate the necessity of taking into account all the selection effects discussed here when the PLS data are used, we shall consider the existence of the asteroid jetstream within the Nysa family suggested by van Houten et al. (1970). This was the only jetstream detected in PLS. Having 77 members with first-class orbits, the Nysa family is the most abundant in the PLS data; it constitutes a twin system with the Michela family (26 members), differing only slightly in proper inclination. Van Houten et al. have found that a rectangle covering 22 percent of the β/γ diagram contains as much as 54 percent of the Nysa asteroids, and attribute this to the presence of a jetstream. In fact, the a priori probability of such a concentration in a random sample is less than one in a million. Nevertheless, it can be shown that the jetstream does not exist.

First, let us eliminate the longitude effect by constructing separate β/γ diagrams for different magnitude intervals. The result is shown in figure 5. We see that the concentration in β appears only with the incompleteness of the data ($m_0 > 19.0$) and becomes particularly prominent at $m_0 > 20.0$. This is

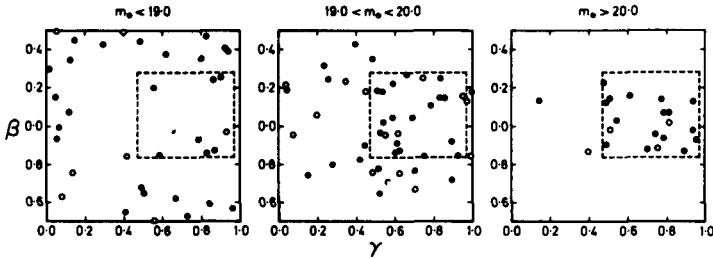

Figure 5.—The β/γ diagrams for the members of the twin asteroid family Nysa (black dots) and Michela (open circles). Dashed rectangles are the limits of the Nysa jetstream according to van Houten et al. (1970).

exactly the same selection effect as shown in figure 1. The excess around $\beta = 0$ is due to very faint asteroids that would be beyond the apparent magnitude threshold if they had not been moving near their perihelia in the area photographed.¹

To explain all the irregularities, it remains to elucidate the relative avoidance of proper nodes at $0.2 < \gamma < 0.4$, appearing already at $m_0 < 19.0$. This effect is essentially identical with that shown in figure 3(b). The outer edges of the survey plates cut off the asteroids moving at a distance of more than $5^\circ.9$ from the ecliptic. The boundary can be represented in a polar diagram with coordinates Ω, i by parallel straight lines passing the pole ($i = 0$) at the distance ϑ in position angles $\Omega = \lambda + 90^\circ$ and $\Omega = \lambda + 270^\circ$. ϑ is given by

$$r \sin (5^\circ.9 - \vartheta) = \sin 5^\circ.9 \tag{7}$$

or, with a satisfactory approximation,

$$\vartheta = 5^\circ.9 \left(1 - \frac{1}{r} \right) \tag{8}$$

Inserting for r , in turn, the minimum perihelion distance $r = a(1 - e) = 1.81$, the median semimajor axis $r = a = 2.39$, and the maximum aphelion distance $r = a(1 + e) = 2.96$ of the Nysa family, we obtain the limits at which the selection effect begins to operate A , eliminates a majority of objects B , and eliminates all objects C . With regard to the selection in longitude (preference for $\pi \cong \lambda$), the effective limit that cuts off one-half of the asteroids passes somewhere between A and B .

¹It has been shown elsewhere (Kresák, 1969) that a similar effect related to the alinement of the lines of apsides may produce spurious evidence of the existence of asteroidal jetstreams even among the numbered asteroids. As a matter of fact, all three jetstreams found by Alfvén (1969) within the Flora family have β near 0.

The Ω/i diagram for the Nysa and Michela families is plotted in figure 6. By the definition $\mu \approx \text{constant}$, the members of each family cluster on the circumference centered at the pole of precessional motion, which for $a = 2.39$ corresponds to $\Omega_0 = 83^\circ$ and $i_0 = 0.86^\circ$ (table I). The plate limits A , B , and C do not intersect the circumference of the Michela family, which is accordingly untouched by this selection effect. They also do not intersect the circumference of the Nysa family at $\Omega = \lambda + 270^\circ \approx 280^\circ$ because of its eccentric position; but they do cut off a considerable part of it around $\Omega = \lambda + 90^\circ \approx 100^\circ$. Transforming back to the proper element γ we find that the selection should have eliminated some members of the Nysa family at $0.15 < \gamma < 0.40$ (dotted part of the circle), with a loss exceeding 50 percent at $0.25 < \gamma < 0.30$. This is in excellent agreement with the position of the vertical gap in figure 5. Thus the observed structure of the Nysa family is fully explained and any indication of a jetstream disappears.

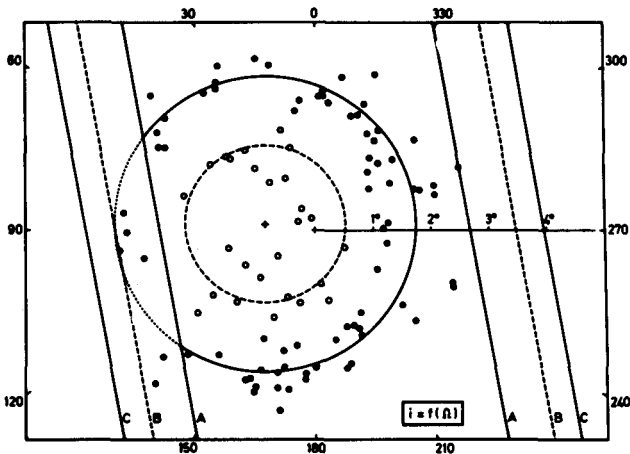

Figure 6.—Distribution of the members of the twin asteroid family Nysa (black dots) and Michela (open circles) in Ω and i . The center cross is the fundamental plane of the precessional motion of the orbits; the large circles are median values of proper inclination μ ; the slanting lines are the mean limits of detection on PLS plates in perihelion A , at the mean heliocentric distance B , and in aphelion C .

Figure 6 also presents an interesting view on the relationships within the twin families Nysa and Michela. The latter is shown to fill rather uniformly, by the poles of the precessional motion, the circumference occupied by the former rather than to form another concentric ring. It is difficult to state whether there is also a similar outer halo composed of asteroids with higher proper inclinations because the selection effects of the PLS would have eliminated a great proportion of objects moving in such orbits.

REFERENCES

Alfvén, H. 1969, Asteroidal Jet Streams. *Astrophys. Space Sci.* **4**, 84-102.
 Brouwer, D. 1951, Secular Variations of the Orbital Elements of Minor Planets. *Astron. J.* **56**, 9-32.
 Brouwer, D., and Clemence, G. M. 1961, *Methods of Celestial Mechanics*, p. 527. Academic Press, Inc. New York.
 Houten, C. J. van, Houten-Groeneveld, I. van, Herget, P., and Gehrels, T. 1970, Palomar-Leiden Survey of the Faint Minor Planets. *Astron. Astrophys. Suppl.* **2**, 339-448.
 Kresák, L. 1967, The Asymmetry of the Asteroid Belt. *Bull. Astron. Inst. Czech.* **18**, 27-36.
 Kresák, L. 1969, The Discrimination Between Cometary and Asteroidal Meteors. II. Orbits and Physical Characteristics. *Bull. Astron. Inst. Czech.* **20**, 231.

DISCUSSION

VAN HOUTEN: Kresák argues that the number of asteroids found in the PLS is larger than the average value for a field of equal size along the ecliptic. This conclusion is based on a combination of the following points:

- (1) There is a preferential orientation of asteroid perihelia in the direction of the perihelion of Jupiter's orbit.
- (2) The PLS was taken in the direction of the perihelion of Jupiter's orbit.
- (3) Asteroids are usually discovered near perihelion.

In his figure 1, Kresák shows that, indeed, there is a pronounced asymmetry in the distribution of perihelia for asteroids found in the PLS. This may give the impression that there is a large excess of PLS objects compared to those of the general field, supporting Kresák's conclusion mentioned above. But before this conclusion can be safely made, the PLS distribution of perihelia should be compared with that of the numbered asteroids. This comparison is shown in table D-I. The PLS material of 980 first-class orbits is compared with the data of Bauschinger (1901), who used the numbered minor planets 1 to 463, and Kiang (1966), who used 791 asteroids with $m_0 < 15$. The material is divided into four intervals; the first interval is centered on Jupiter's perihelion.

The results of Bauschinger and Kiang are practically identical; and they show that in the PLS there is a small excess, about 2 or 3 percent, of orbits oriented in the direction of Jupiter's perihelion. This excess is so small that it hardly influences the number statistics. Accordingly Kresák's result of a ratio of 1.26 of the asteroids near the vernal equinox compared to those near the autumnal equinox is far too large.

KRESÁK: A ratio of 1.26 of the two extremes corresponds to an excess of 12 percent in the direction of the PLS, and 10 to 11 percent in the first interval of table D-I, as

TABLE D-I.—Comparison of the Distribution of Perihelia

Intervals, $\omega + \Omega$	Distributions, percent		
	PLS	Bauschinger	Kiang
330° to 60°	40	38	38
60 to 150	23	24	24
150 to 240	11	14	15
240 to 330	26	24	23

compared with the average abundance along the ecliptic. Table D-I suggests a relative excess of $2/38$ (i.e., 5 to 6 percent) in the first interval, and the differences in the ratios of the first to the third interval (3.6 for the PLS and 2.5 to 2.7 for the samples of numbered asteroids) appear rather significant. Thus the disagreement is not as bad as it appears to be at first glance. Moreover, the predicted ratio is based on the assumption that the actual degree of alinement is the same for bright and faint asteroids, which cannot be verified by a one-directional survey. The correlation between eccentricity and inclination, producing an additional latitudinal dispersion of asteroids in the direction of Jupiter's perihelion, might remove the remaining discrepancy. Anyway, a definitive solution of this complex problem can be obtained only from a comparison sample taken in the opposite direction.

DISCUSSION REFERENCES

- Bauschinger, J. 1901, Tabellen zur Geschichte und Statistik der kleinen Planeten. Veröff. Königl. Astron. Recheninst. Berlin no. 16.
- Kiang, T. 1966, Bias-Free Statistics of Orbital Elements of Asteroids. *Icarus* 5, 437-449.