

PART I

SATELLITES AND PLANETS

HIGH ORDER RESONANCES IN THE EVOLUTION OF THE LUNAR ORBIT

J. KOVALEVSKY
CERGA, Grasse, France

ABSTRACT

This paper deals with the long term evolution of the motion of the Moon or any other natural satellite under the combined influence of gravitational forces (lunar theory) and the tidal effects. We study the equations that are left when all the periodic non-resonant terms are eliminated. They describe the evolution of the mean elements of the Moon. Only the equations involving the variation of the semi-major axis are considered here. Simplified equations, preserving the Hamiltonian form of the lunar theory are first considered and solved. It is shown that librations exist only for those terms which have a coefficient in the lunar theory larger than a quantity A which is function of the magnitude of the tidal effects. The solution of the general case can be derived from a Hamiltonian solution by a method of variation of constants. The crossing of a libration region causes a retardation in the increase of the semi-major axis. These results are confirmed by numerical integration and orders of magnitude of this retardation are given.

I. INTRODUCTION

The secular acceleration of the Moon has been studied for many years. It is well known that the lunar orbit undergoes a secular acceleration due to the Earth's tidal deformation. Presently, this acceleration is estimated to $dn/dt = -25''/\text{century}^2$ (see, for instance, Calame and Mulholland, 1978, Ferrari et al., 1980 or Cazenave and Daillet, 1981). As it is shown by Lambeck (1978), this value seems to have been surprisingly constant throughout the last 500 million years as inferred from the paleontological evidence from fossile corals or bivalves (e.g. Johnson and Nudds, 1974).

In the general theory of tides, it is customary to introduce a lag due to the viscosity of the Earth between the direction of the Moon and the main axis of the tidal bulge (Melchior, 1973). This angle corresponds to a delay Δt of about 10 minutes between the excitation and the deforma-

tion. It is principally a function of the second order Love number k_2 .

Observational evidence quoted above allows us to assume that this time-lag was more or less constant in the past. In this case, it is possible to integrate the equation giving the variations of the semi-major axis of the lunar orbit (MacDonald, 1966). It is found that, when the solution is extended in the past, one has $a = 0$ at about -1.8×10^{-9} year. This number is $2 \frac{1}{2}$ times too small in comparison with the actual age of the Earth-Moon system. In order to interpret this difference, it can be alleged that in the earlier past, Love numbers were different so that the time lag was smaller, allowing a much slower tidal evolution.

The goal of the work which is reported here is to attempt to find other - purely dynamical - effects that might affect the speed of the secular increase of the lunar semi-major axis.

II. EQUATIONS

The equations that describe the evolution of the Earth-Moon system are obtained from the combination of the usual equations of the lunar theory and the equations that describe the tidal evolution of the Moon. In the present work, the latter were taken from a series of papers published by Mignard on the evolution of the Earth-Moon system (Mignard, 1979 and 1980) that seem to be the most complete ever published. We introduce the following parameter :

$$k = - \frac{3Gm^2 k_2 R^5 \Delta t}{\mu} \quad (1)$$

where G is the geocentric constant of gravitation, k_2 is the Love number describing the second order term of the Earth tidal potential, R is the radius of the Earth and m is the mass of the Moon, the Earth's mass M being taken as unity.

$$\mu = mM / (m + M)$$

The numerical value of k is $-2.3 \cdot 10^{-14}$ if the unit of mass is the Earth's mass, the unit of length, the semi-major axis of the lunar orbit and the unit of time, $1/2\pi$ the period of the lunar orbit.

We introduce also σ/n , ratio of the rotational speed of the Earth to the mean motion of the Moon n .

Mignard (1980) gives the general expressions of the components of the tidal acceleration due to a Love number k_2 of any order ℓ in function of the osculating elements of the lunar orbit. Taking $\ell = 2$ and substituting the expressions in the Gaussian equations of motion (see for instance, Kovalevsky, 1967), one gets the basic equations giving the variation of the osculating elements in function of time. Let us reproduce the equations for the metric elements.

$$\frac{da}{dt} = \frac{2k}{a^7} \frac{1}{1-e^2} \left(\frac{a}{r}\right)^8 (1 + 2e^2 + 2e \cos v - e^2 \cos 2v) - \frac{2\sigma}{n} \frac{k}{a^7} \sqrt{1-e^2} \left(\frac{a}{r}\right)^8 (\cos \epsilon \cos i + \sin \epsilon \sin i \cos \Omega) \tag{2}$$

$$\frac{de}{dt} = \frac{k}{a^8} \left(\frac{a}{r}\right)^8 (3e + 2 \cos v - e \cos 2v) - \frac{\sigma}{n} \frac{k}{a^8} \frac{1}{\sqrt{1-e^2}} \left(\frac{a}{r}\right)^6 \left(\frac{3e}{2} + 2\cos v + \frac{e}{2}\cos 2v\right) (\cos \epsilon \cos i + \sin \epsilon \sin i \cos \Omega) \tag{3}$$

$$\frac{di}{dt} = \frac{1}{4} \frac{\sigma}{n} \frac{k}{a^8} \frac{1}{\sqrt{1-e^2}} \left(\frac{a}{r}\right)^6 \begin{cases} 2 \sin i (1 + 2 \cos 2(\omega + v)) \\ + 2 \sin \epsilon \cos i \cos \Omega \\ + \sin \epsilon (1 + \cos i) \cos(2\omega + 2v + \Omega) \\ - \sin \epsilon (1 - \cos i) \cos(2\omega + 2v - \Omega) \end{cases} \tag{4}$$

The classical osculating elements are noted $a, e, i, \Omega, \omega, \ell$. Furthermore, r is the radius vector, v is the true anomaly, ϵ is the obliquity of the ecliptic.

When developed in trigonometric functions of ℓ , the right-hand members will be even series of ℓ, Ω and ω . Similar equations can be derived for the angular elements Ω, ω and ℓ . The right-hand members are odd in v (and, hence, in ℓ) and therefore do not produce secular effects. We do not have to consider them in the present study. Equations with the same properties may be derived if Delaunay variables are chosen instead of the elements.

The terms originated by the solar perturbation derive from a disturbing function of the form :

$$R = n'^2 a^2 \sum_{ijkh} A(e, e', \sin \frac{i}{2}, \frac{a}{a'}, \mu) \cos(i\Omega + j\omega + k\ell + h\ell') \tag{5}$$

where the primed quantities refer to the apparent ellipse described by the Sun around the Earth and are considered as being constant in the problem. The contribution to the right-hand members is a series of odd terms in the case of equations (2) to (4), and even terms in the equations relative to angular elements.

III. Elimination of terms

The complete equations, written in a pseudo-hamiltonian form using conjugate variables ξ_j, η_j ($j = 1$ to 3) have the following form :

$$\begin{cases} \frac{d\xi_j}{dt} = \frac{\partial F}{\partial \eta_j} + X_j \\ \frac{d\eta_j}{dt} = \frac{\partial F}{\partial \xi_j} + Y_j \end{cases} \quad (6)$$

where F is the Hamiltonian of the main lunar problem and X_j, Y_j are the tidal terms. Periodic terms may be eliminated by Delaunay method or any of the derived methods (von Zeipel, Lee series, etc...). As shown by Brouwer and Horı (1961), the elimination can also be applied to the terms that have not the hamiltonian form. Following their theory, after the elimination of all the periodic terms of the lunar theory, equations (6) become :

$$\begin{aligned} \frac{d\xi'_j}{dt} &= X_j(\xi', \eta') + \sum_i \left(\frac{\partial X_j}{\partial \xi'_i} \delta \xi_i + \frac{\partial X_j}{\partial \eta'_i} \delta \eta_i \right) \\ \frac{d\eta'_j}{dt} &= - \frac{\partial F'(\xi')}{\partial \xi'_j} + Y_j(\xi', \eta') + \sum_i \left(\frac{\partial Y_j}{\partial \xi'_i} \delta \xi_i + \frac{\partial Y_j}{\partial \eta'_i} \delta \eta_i \right) \end{aligned}$$

where the primed quantities indicate the new Hamiltonian or variables after the elimination has been performed. The periodic terms of X_j and Y_j can be similarly eliminated. Because of the smallness of k , a first order solution is sufficient, so that it may just be added to the solution. After this, taking into account the fact that Y_j are odd functions of the arguments, the equations become :

$$\begin{cases} \frac{d\xi'_j}{dt} = X_j(\xi') \\ \frac{d\eta'_j}{dt} = \frac{\partial F'(\xi')}{\partial \xi'_j} \end{cases} \quad (7)$$

Their solution gives the secular-variations of all the six variables.

IV. EQUATIONS FOR THE RESONANT CASE

This procedure fails if, among the terms of the lunar theory, there exist one or several terms whose period is so large that they cannot be eliminated and that resonance theory has to be applied. Let us consider one of such arguments :

$$\theta = i\Omega + j\omega + k\ell + h\ell'$$

The corresponding mean motion is

$$n_\theta = in_\Omega + jn_\omega + kn_\ell + hn'$$

where the indexed n are functions of the mean elements a'', e'' and i''. If one takes the present values of these elements, there is no known combination of integers i, j, k, h that leads to a sufficiently small n_θ. But since in the past a'', e'' and i'' were slowly varying because of the tidal effects, many such combinations may have existed. Let us consider such a case and let θ be the corresponding critical argument. The elimination procedure being applied to all the other - non critical - periodic terms, we end up with equations of the form :

$$\begin{cases} \frac{d\xi'_j}{dt} = \overline{X}_j(\xi') + x_j \sin \theta, \\ \frac{d\eta'_j}{dt} = -\frac{\partial F'(\xi')}{\partial \xi'_j} + y_j \cos \theta \end{cases} \tag{8}$$

It is possible, by a canonical transformation, to have θ as one of the angular variables so that the other two become ignorable, and we are left with three equations in ξ' and one in η' = θ. As a final transformation, we shall come back to the mean elliptic elements and the equations will have the following form :

$$\begin{cases} \frac{da}{dt} = \alpha_1 + \beta_1 \sin \theta \\ \frac{de}{dt} = \alpha_2 + \beta_2 \sin \theta \\ \frac{di}{dt} = \alpha_3 + \beta_3 \sin \theta \\ \frac{d\theta}{dt} = n_\theta + y_\theta \cos \theta \end{cases} \tag{9}$$

where the coefficients are all functions of a, e and i. Note that, at this point, we have dropped the primes and that now on, unprimed quantities are used for the mean elements, solutions of (9).

V. REDUCED EQUATIONS IN THE LUNAR CASE

In this paper, we shall neglect the equations in e and i. In other terms, we shall assume that the variations in e and i are sufficiently small so as not to introduce in the first and last equations sizeable effects. This is clearly a simplifying assumption made in order to study the behaviour of the solution. Later, the equations (9) should be

discussed as a whole. Using (2), one obtains :

$$\begin{cases} \frac{da}{dt} = \frac{2k}{a^7} - \frac{2\sigma}{\sqrt{GM}} \frac{k}{a^{11/2}} \cos \epsilon \cos i + Q \sin \theta \\ \frac{d\theta}{dt} = n_{\theta}(a) + Q' \cos \theta \end{cases} \quad (10)$$

where Q and Q' are the coefficients of the resonant terms coming from the lunar theory.

In a last change of variables, let us put

$$a = a_0 + x \quad (11)$$

where a_0 is the value of such that

$$n_{\theta}(a_0) = 0$$

If now, we put

$$A = \frac{2k}{a_0^7} - \frac{2\sigma}{\sqrt{GM}} \frac{k}{a_0^{11/2}} \cos \epsilon \cos i$$

$$B = \left(\frac{\partial A}{\partial a} \right)_{a_0} = \frac{-14k}{a_0^8} + \frac{11\sigma}{\sqrt{GM}} \frac{k \cos \epsilon \cos i}{a_0^{13/2}}$$

$$n_{\theta} = n_{\theta}(a_0) + \left(\frac{\partial n_{\theta}}{\partial a} \right)_{a_0} x = 2 Gx$$

the equations (10) become

$$\begin{cases} \frac{dx}{dt} = A - Bx + Q \sin \theta \\ \frac{d\theta}{dt} = 2 Gx + Q' \cos \theta \end{cases}$$

In order to have a feeling of the actual order of magnitude of the coefficient, the present values of A and B are :

$$A = 1.10 \cdot 10^{-12}$$

$$B = 5.95 \cdot 10^{-12}$$

Q and Q' can be any term taken from the lunar theory, nothing can be said about their size. However, the present study has dealt with values of Q smaller than 10^{-9} or 10^{-10} . Finally, G is normally a finite number. This means that Q' is negligible with respect to $2 Gx$. So, we shall effectively neglect it and reduce the equations to :

$$\begin{cases} \frac{dx}{dt} = A - Bx + Q \sin \theta \\ \frac{d\theta}{dt} = 2 Gx \end{cases} \quad (12)$$

Equations (12) describe the behaviour of the semi-major axis a and of the critical argument θ when a is close to the resonant situation. It is important to note that (12) is not a hamiltonian system.

VI. STUDY OF SOME PARTICULAR CASES

Let us first describe the solution of some particular cases of the system (12). This will help to understand the behaviour of the general system.

6.1. $Q = 0$

Equations (12) describe simply the secular effect of the tides on the semi-major axis. The equations separate and one gets the general solution

$$t - t_0 = \frac{1}{B} \text{Log} \left| \frac{A - Bx}{A} \right|$$

or

$$x = \frac{A}{B} \left[1 - \exp \left(-B(t - t_0) \right) \right] \quad (13)$$

This is equivalent to the general solution as given by MacDonald (1966). For small values of x , this solution may be approximated by a linear function of time

$$x = A (t - t_0) \quad (14)$$

6.2. $A = B = 0$

The system (12) describes a resonant situation in the lunar theory. It has a Hamiltonian

$$H = - Gx^2 - Q \cos \theta$$

The variations of x in function of θ are described in the $x - \theta$ plane by the integral $H = C$. The equilibrium points correspond to the maxima and minima of $H=C$ in the $x^2 - \theta$ plane. For various values of C , one gets classical libration or circulation orbits and the limiting cases of a stable equilibrium or asymptotic orbits (see fig. 1).

6.3. $B = 0, A \neq 0$

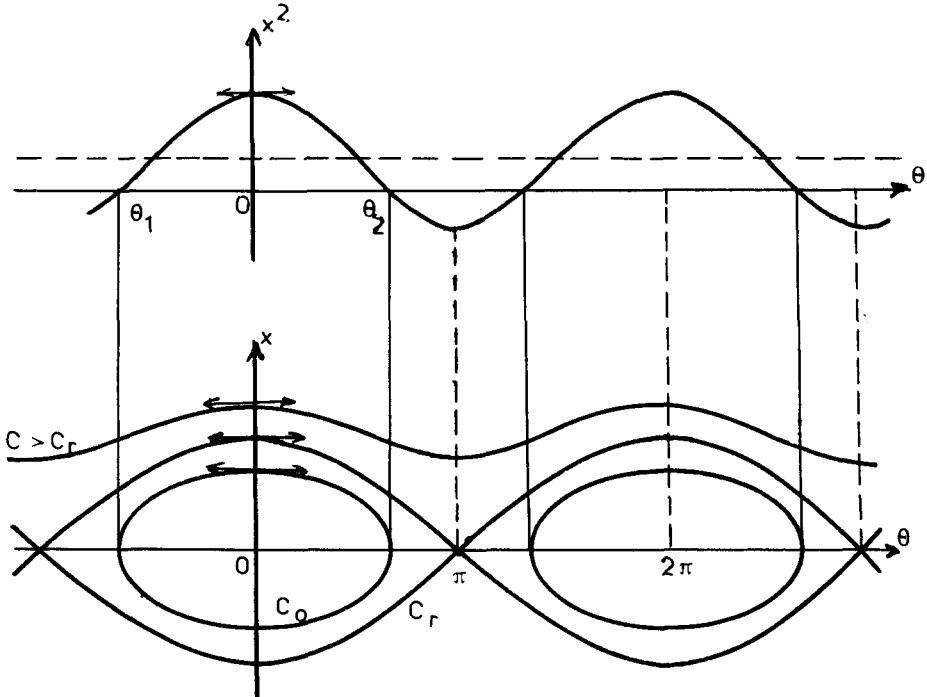

Figure 1. Solution of the $A = B = 0$ case in the $x - \theta$ plane.

The system (12) now describes the motion under a resonant situation with a tidal effect that does not depend upon the semi-major axis. It has the form

$$\begin{cases} \frac{dx}{dt} = A + Q \sin \theta \\ \frac{d\theta}{dt} = 2 Gx \end{cases} \tag{15}$$

and has the Hamiltonian $H = A\theta - Q \cos \theta - Gx^2$, so that the integral $H = C$ exists and may be used to discuss the motion. In the $x^2 - \theta$ plane, curves $H = C$ are sinusoidal curves constructed with respect to an inclined axis.

$$x^2 = \frac{C}{G} + \frac{A}{G} \theta - \frac{Q}{G} \cos \theta \tag{16}$$

As in the preceding case, equilibrium points correspond to maxima or minima of (15) in the $x' - \theta$ plane. They are given by

$$\frac{\partial H}{\partial x} = 0 \text{ or } x = 0 \quad ; \quad \frac{\partial H}{\partial \theta} = 0 \text{ or } \sin \theta = -\frac{A}{Q}$$

Their existence depends upon the value of the ratio A/Q .

a) $|A| < |Q|$. The situation is described in figure 2. The integral curves in the $x - \theta$ plane have several components and, depending upon the initial value of θ , one may be trapped in a libration orbit or be on a circulation orbit.

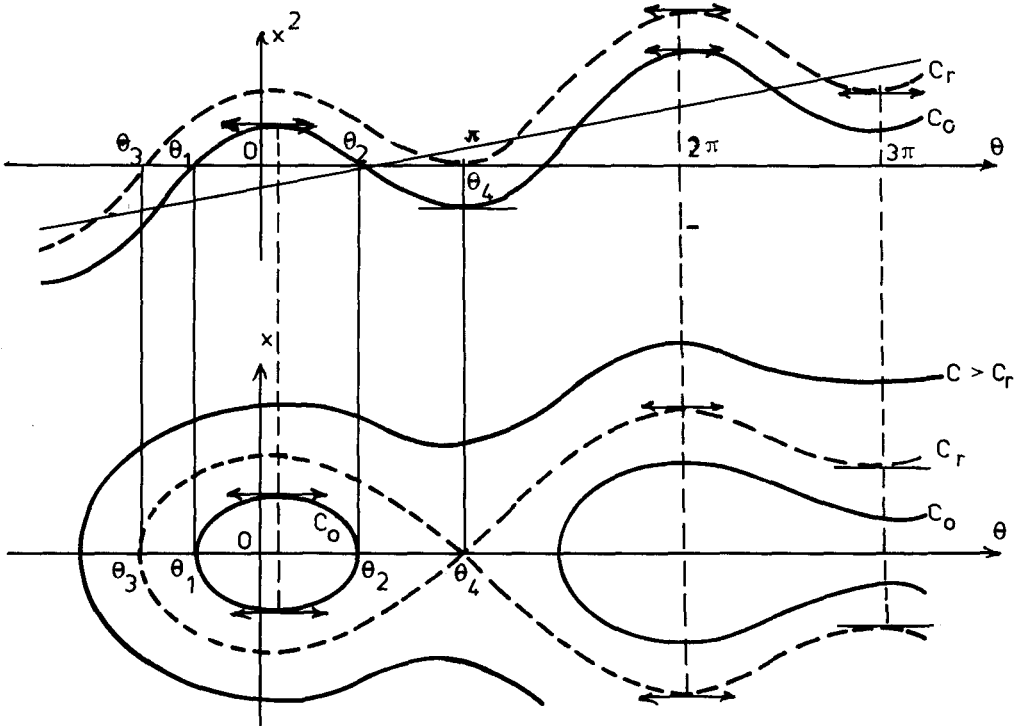

Figure 2. Solution for the $B = 0$ case in the $x - \theta$ plane.

The entire picture has a periodicity of 2π in θ corresponding to $2\pi A$ in C . However, physically, there is continuity when C varies and one should consider only the curves that originate from a given stable equilibrium point. When C increases, starting from such a point, one has successively libration orbits, a limiting asymptotic orbit and then, symmetric circulation orbits.

The libration period is given by :

$$P = \frac{2}{\sqrt{G}} \int_{\theta_1}^{\theta_2} \frac{d\theta}{\sqrt{C + A\theta - Q \cos \theta}}$$

where θ_1 and θ_2 are the values of θ surrounding the stable equilibrium in θ_0 and for which $x^2 = 0$ (see figure 2).

b) $|A| > |Q|$. The $x^2 = f(\theta)$ curve has no horizontal tangent and it crosses the x^2 axis in a single point P (figure 3). The corresponding orbit is a circulation orbit with continuously increasing x . So, in practice, if the terms $Q \sin \theta$ disturb the purely tidal evolution of the system, they do not change the general evolutionary behaviour.

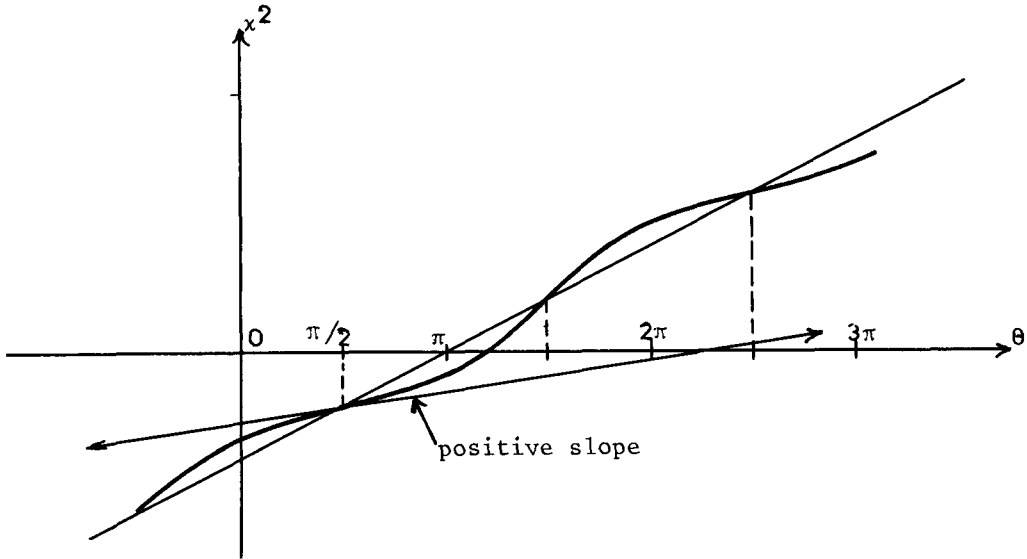

Figure 3. Constant C curves in the $x^2 - \theta$ plane when $A > |Q|$

c) $A = |Q|$. One has the same situation as above, except that there exist unstable equilibrium points for $\theta = \pi/2 + k\pi$

VII. EXTENSION TO THE GENERAL CASE

Let us now consider the complete equations (12), assuming $B \neq 0$. There is no more integral of the type that was used for Hamiltonian systems studied in the last section.

Qualitatively, one may consider that equations (12) are represented by (15) where A is allowed to be slightly modified by Bx . In practice, A and B are of the same order of magnitude whereas x in the libration region is smaller than 10^{-4} . It is therefore possible to consider (12) as a perturbed case of (15) where A is replaced by $A_0 - Bx$, Bx remaining very small as compared with A_0 . The equations that are obtained are analogous to those studied by Burns (1979) for the rotation of Mercury. It is also possible to apply the adiabatic invariant theory (Henrard, 1982).

Let us consider a solution of the reduced system (15), solution that can explicitly be obtained, since the system is integrable.

$$\begin{cases} x_o = x_o(t, C, p) \\ \theta_o = \theta_o(t, C, p) \end{cases} \tag{17}$$

where C and p are the two independent integration constants. Let us construct the general solution of (12) in the form (17) where increments of C and p are now considered as functions of time.

$$\begin{cases} C = C_o + \Delta C(t) \\ p = p_o + \Delta p(t) \end{cases} \tag{18}$$

The solution of (12) has the form :

$$\begin{cases} x = x_o(t, C_o, p_o) + \left(\frac{\partial x_o}{\partial C}\right)_o \Delta C + \left(\frac{\partial x_o}{\partial p}\right)_o \Delta p \\ \theta = \theta_o(t, C_o, p_o) + \left(\frac{\partial \theta_o}{\partial C}\right)_o \Delta C + \left(\frac{\partial \theta_o}{\partial p}\right)_o \Delta p \end{cases} \tag{19}$$

In order to obtain the differential equations in C and p, let us write the derivatives of (19) :

$$\begin{cases} \frac{dx}{dt} = \frac{dx_o}{dt} + \frac{\partial}{\partial C} \left(\frac{dx_o}{dt}\right) \Delta C + \frac{\partial}{\partial p} \left(\frac{dx_o}{dt}\right) \Delta p + \frac{\partial x_o}{\partial C} \frac{d\Delta C}{dt} + \frac{\partial x_o}{\partial p} \frac{d\Delta p}{dt} \\ \frac{d\theta}{dt} = \frac{d\theta_o}{dt} + \frac{\partial}{\partial C} \left(\frac{d\theta_o}{dt}\right) \Delta C + \frac{\partial}{\partial p} \left(\frac{d\theta_o}{dt}\right) \Delta p + \frac{\partial \theta_o}{\partial C} \frac{d\Delta C}{dt} + \frac{\partial \theta_o}{\partial p} \frac{d\Delta p}{dt} \end{cases}$$

and substitute whenever possible the right-hand members of (15) for dx_o/dt and $d\theta_o/dt$. Then we equate them to the right-hand members of (12) where x and θ are replaced by (19) and where second order terms in ΔC and Δp are neglected. This permits to linearize the system in ΔC and Δp that describes locally the general solution in the form (17). After some algebra, calling

$$\begin{cases} y = \frac{\partial x_o}{\partial C} \Delta C + \frac{\partial x_o}{\partial p} \Delta p \\ z = \frac{\partial \theta_o}{\partial C} \Delta C + \frac{\partial \theta_o}{\partial p} \Delta p \end{cases} \tag{20}$$

one finally obtains the following system :

$$\frac{dy}{dt} - By - Qz \cos \theta_o = Bx_o \quad ; \quad \frac{dz}{dt} - 2Gy = 0 \tag{21}$$

The system (21) is equivalent to (12), the solution being written under the form (17). It describes how the actual perturbed orbit can be considered as slowly varying orbits of the kind studied in VI-3.

If we consider the solutions trapped in the libration region, they will only very slightly differ from the orbits given in figure 2. In particular, in the case $B = 0$, the mean value in time of x is zero, because of the symmetry dx/dt and of the orbit with respect to the axis $x = 0$. At present, one has, neglecting higher order terms :

$$\frac{dx}{dt} = \frac{dx_0}{dt} - Bx_0$$

Figure 4 shows simultaneously the orbit $x_0 = f(\theta)$, the curve dx_0/dt and dx/dt . It results that the mean value \bar{x} of x over a period of θ is positive, since the time spent in the upper half of the orbit is larger than in the lower. However, \bar{x} is of the order of $B|x_0|$ and, therefore, is very small. Consequently, while the body is trapped in libration, the mean value of the semi-major axis is practically constant.

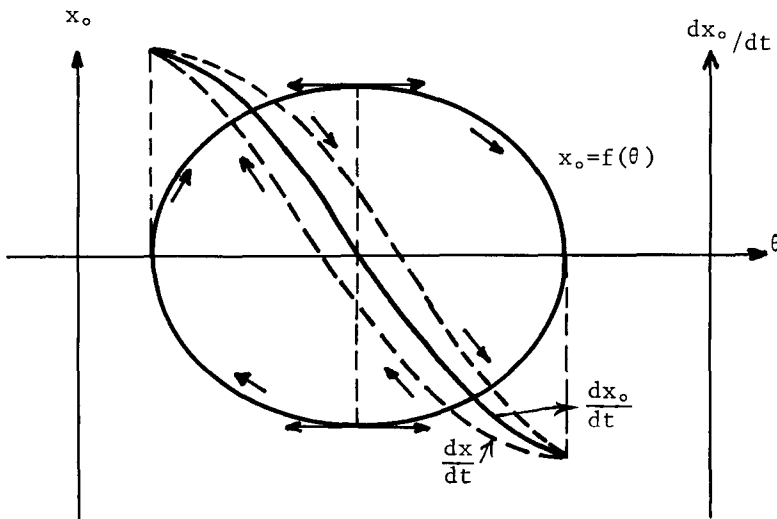

Figure 4. Variations of x_0 , dx_0/dt and dx/dt for a libration orbit.

VIII. EVOLUTION OF THE ORBIT

Using the preceding results, it is possible to present a qualitative description of the evolution with time of the semi-major axis of the orbit (i.e. x).

8.1. Before entering the libration region.

Outside the libration region, it is still possible to eliminate the term $Q \sin \theta$ from the equations (6), so that finally only the secular terms are left in the reduced equations. The evolution of the orbits is described by the case VI-1. There is a continuous increase of x given by (13) or (14).

8.2. While crossing the libration region.

Two cases are to be considered.

a) $|Q| \leq A$. There exist no libration regions (see VI-3-b) so that the evolution of x continues while the critical argument n_θ crosses the value zero. It is however to be expected that this evolution is somewhat perturbed by this term, especially if $|Q|$ is not too much smaller than A .

b) $|Q| > A$. The orbit is trapped in the libration region and evolves in it as described in section VII. In this first approach to the problem, we have not evaluated the time during which it is trapped nor did we consider the capture probabilities. If it is captured, during a certain time ΔT , the semi-major axis does not change.

8.3. After leaving the libration region.

The situation is the same as in the first case. The $Q \sin \theta$ term can again be eliminated and formulae (13) or (14) are again valid.

Finally, if $|Q| \leq |A|$, the critical term does not affect the general increase of the semi-major axis. If $|Q| > |A|$, this increase is stopped during the time ΔT defined above.

IX. NUMERICAL SIMULATIONS

A number of numerical integrations was performed over the system (12). It led to confirm some of the results given in the present paper.

9.1. Effects of $|Q| / A$.

Figure 5 shows the results of numerical integrations of the equations (12) with $A = 1.1 \cdot 10^{-12}$ and $B = 5.95 \cdot 10^{-12}$, when Q varies between 10^{-13} and $5 \cdot 10^{-11}$. The dotted line represents the variation of x with $Q = 0$ (case VI-1). The separation between the trapped and untrapped orbits appears very clearly for $Q_0 = 1.113 \cdot 10^{-12}$. The difference with the theoretical value A comes from the disturbing effect of B (figure 5).

All these orbits - and many others that were calculated - started from $x = 0$, so that they correspond initially to a position in the libration region. All the orbits with $Q > Q_0$ that were initially trapped, escaped after a certain time. No example of orbit that could not escape was found.

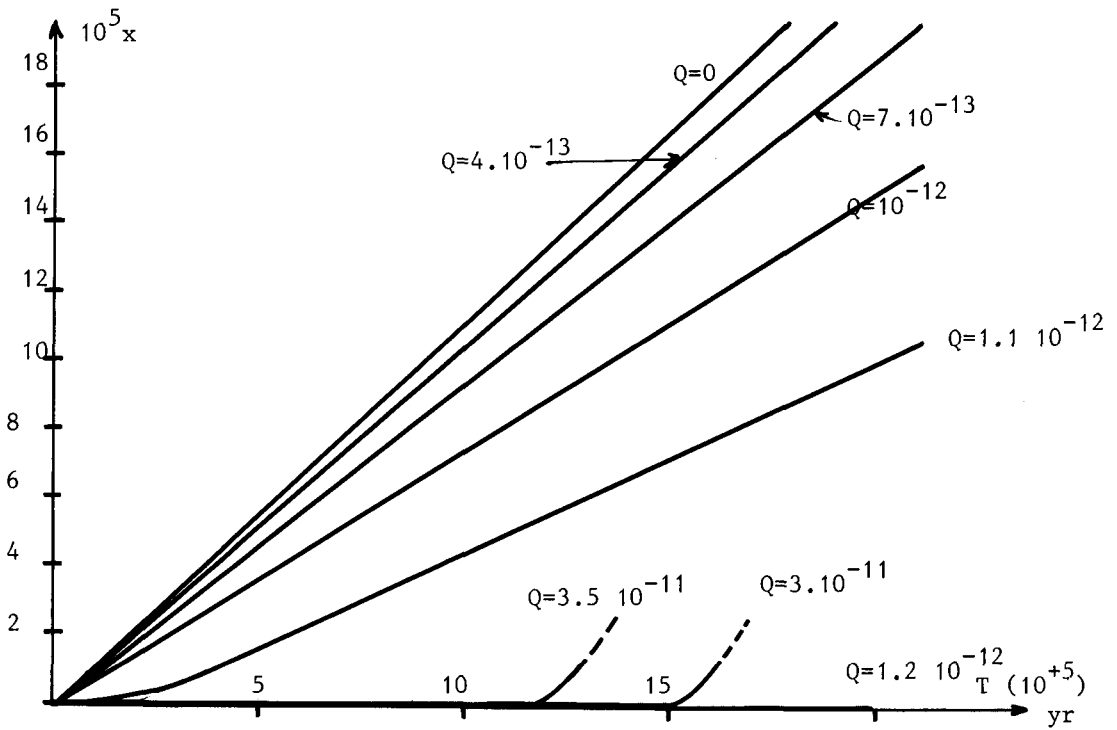

Figure 5. Evolution of x for various values of Q . Curves are stopped when the effect of Q becomes short-periodic and affects the integration scheme.

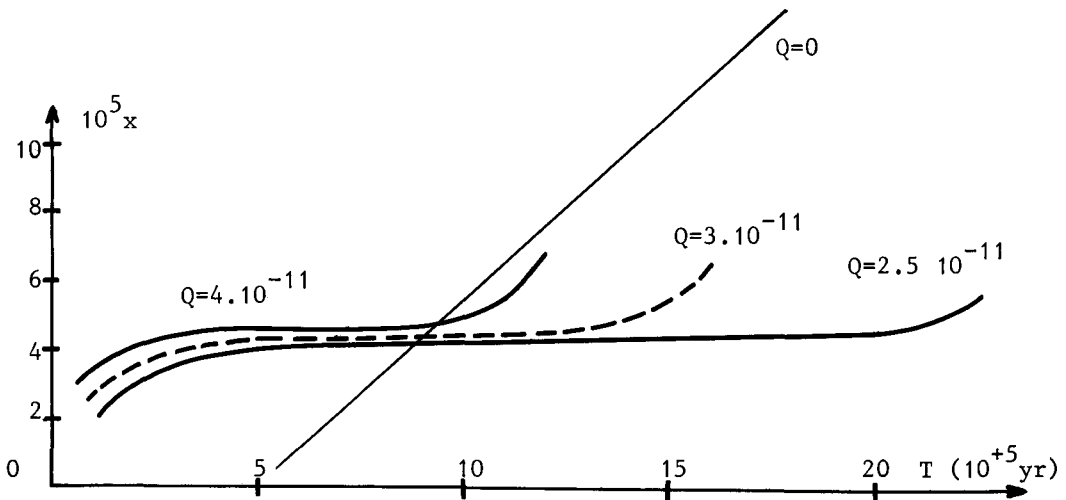

Figure 6. Some evolutionary tracks crossing the libration region. Curves are stopped when the effect of Q becomes short-periodic and affects the integration scheme.

9.2. Case when $Q < Q_0$

It can also be seen that the mean slopes of evolutionary tracks decrease when Q increases for $Q < Q_0$. This effect also plays a role in the lengthening of the evolution time. Several runs have been made also to study how some orbits arrive in the libration region, get trapped and then, escape. Figure 6 gives some examples of such evolutionary tracks. They illustrate the general features that were described in section VII. It would be of interest to explain analytically more detailed features that appear in these curves.

REFERENCES

- Brouwer, D. and Hori, G., 1961, *Astron. J.*, 66, p.193.
- Burns, T.J., 1979, *Celestial Mechanics*, 19, p. 297.
- Calame, O. and Mulholland, J.D., 1978, *Science*, 199, p. 977.
- Cazenave, A. and Daillet, S., 1981, *J. Geophys. R.*, 86, p. 1659.
- Ferrari, A.J., Sinclair, W.S., Sjogren, W.L., Williams, J.G. and Yoder, C.F., 1981, *J. Geophys. R.*, 85, p. 3939.
- Henrard, J., 1982, *Celestial Mechanics*, 27, p. 3.
- Johnson, G.A.L. and Nudds, J.R., 1974, in "Growth, Rythms and the History of the Earth's Rotation", G.D. Rosenberg and S.K. Runcorn ed., John Wiley and sons, London, p. 27.
- Kovalevsky, J., 1967, "Introduction to Celestial Mechanics", D. Reidel Publ. Co, p. 116.
- Lambeck, K., 1978, in "Tidal Friction and the Earth's Rotation", P. Brosche and J. Sündermann ed., Springer-Verlag, Berlin, p. 145.
- MacDonald, G.J.F., 1966, in "The Earth-Moon System", B.G. Marsden and A.G.W. Cameron ed., Plenum Press, New-York, p. 165.
- Melchior, P., 1973, "Physique et dynamique planétaires", Vander, Louvain, vol. 4, p. 4.
- Mignard, F., 1979, *The Moon and the Planets*, 20, p. 301.
- Mignard, F., 1980, *The Moon and the Planets*, 23, p. 185.