

LETTER TO THE EDITOR

Aminoacylated tmRNA from *Escherichia coli* interacts with prokaryotic elongation factor Tu

JOËLLE RUDINGER-THIRION,¹ RICHARD GIEGÉ,¹ and BRICE FELDEN²

¹Unité Propre de Recherche 9002 du Centre National de la Recherche Scientifique, Institut de Biologie Moléculaire et Cellulaire, F-67084 Strasbourg, France

²Department of Human Genetics, University of Utah, Salt Lake City, Utah 84112-5330, USA

Keywords: 10Sa RNA; alanylation; minisubstrate; ternary complex; *trans*-translation

Eubacterial tmRNAs (10Sa RNAs) are unique because they function, at least in *Escherichia coli*, both as tRNA and mRNA (for a review, see Muto et al., 1998). These ~360 ± 40-nt-long RNAs are charged with alanine at their 3' ends by alanyl-tRNA synthetases or AlaRS (Komine et al., 1994; Ushida et al., 1994). Alanylation occurs thanks to the presence of the equivalent of the G₃-U₇₀ pair, the major identity element for the alanylation of canonical tRNAs (Hou & Schimmel, 1988; McClain & Foss, 1988). Bacterial tmRNAs also have a short reading frame coding for 9 to 27 amino acids, depending on the species. *E. coli* tmRNA mediates recycling of ribosomes stalled at the end of terminatorless mRNAs, via a *trans*-translation process (Tu et al., 1995; Keiler et al., 1996; Himeno et al., 1997; Withey & Friedman, 1999). In *E. coli*, this amino acid tag is co-translationally added to polypeptides synthesized from mRNAs lacking a termination codon, and the added 11-amino-acid C-terminal tag makes the protein a target for specific proteolysis (Keiler et al., 1996).

Structural analyses based on phylogenetic (Felden et al., 1996; Williams & Bartel, 1996) and probing (Felden et al., 1997; Hickerson et al., 1998) data have led to a compact secondary structure model of *E. coli* tmRNA. These molecules have structural similarities with canonical tRNAs, especially with tRNA acceptor branches (Fig. 1). Further *E. coli* tmRNA contains two modified nucleosides, 5-methyluridine and pseudouridine, located in the T-loop mimic of the molecule (Felden et al., 1998). Its mimicry with tRNA occurs also at the functional level, as it was already shown that tmRNA interacts with certain tRNA specific proteins such as RNase P (Komine et al., 1994), RNase III (Srivastava et al., 1990; Makarov & Apirion, 1992), AlaRS, the

alanyl-tRNA synthetase (Komine et al., 1994; Ushida et al., 1994), and tRNA modifying enzymes (Felden, unpubl. results). What about the other tRNA specific proteins involved in translation?

E. coli tmRNA is found associated with 70S ribosomes in vivo, at about one molecule per 10 ribosomes (Ushida et al., 1994; Komine et al., 1996). How tmRNA enters the ribosomal A-site remains unknown. It could either form a ternary complex after alanylation with elongation factor Tu (EF-TU) and guanosine-5'-triphosphate (GTP), or use another specific pathway. Biochemical studies (Rudinger et al., 1994) as well as the X-ray structures of two ternary complexes (Nissen et al., 1995, 1999) indicate that tRNAs interact with prokaryotic EF-Tu-GTP via the aminoacylated 3' end, the phosphorylated 5' end, and the first 10 bp of the acceptor branch. Crystal structures also show that EF-Tu contacts mainly the ribose-phosphate backbone of the acceptor branch, thus accommodating sequence variability within elongator tRNAs. *E. coli* tmRNA contains a 7-bp acceptor stem followed by a 5-bp T-stem, a 7-nt T-loop, and a classical XCCA single-stranded 3' end (Fig. 1B), as in canonical elongator tRNAs. A sequence comparison between *E. coli* tmRNA and tRNA^{Ala} acceptor branches indicates that 6 out of the first 10 bp of tmRNA are identical to that of tRNA^{Ala} (Fig. 1). This suggests that alanylated tmRNA could be recognized by activated EF-Tu.

The aim of this study was to test the above assumption and to discover whether aminoacylated tmRNA forms a ternary complex with *Thermus thermophilus* EF-Tu and GTP. The choice of the thermophilic protein was dictated by the available crystal structures of ternary complexes comprising this factor, considered to be canonical models for any ternary complex (Nissen et al., 1995, 1999). Hydrolysis-protection assays were used to monitor the ternary complex formation. They are based on the fact that the activated factor, when

Reprint requests to: Brice Felden, Department of Human Genetics, University of Utah, 15N 2030E Room 6250, Salt Lake City, Utah 84112-5330, USA; e-mail: bfelden@genetics.utah.edu.

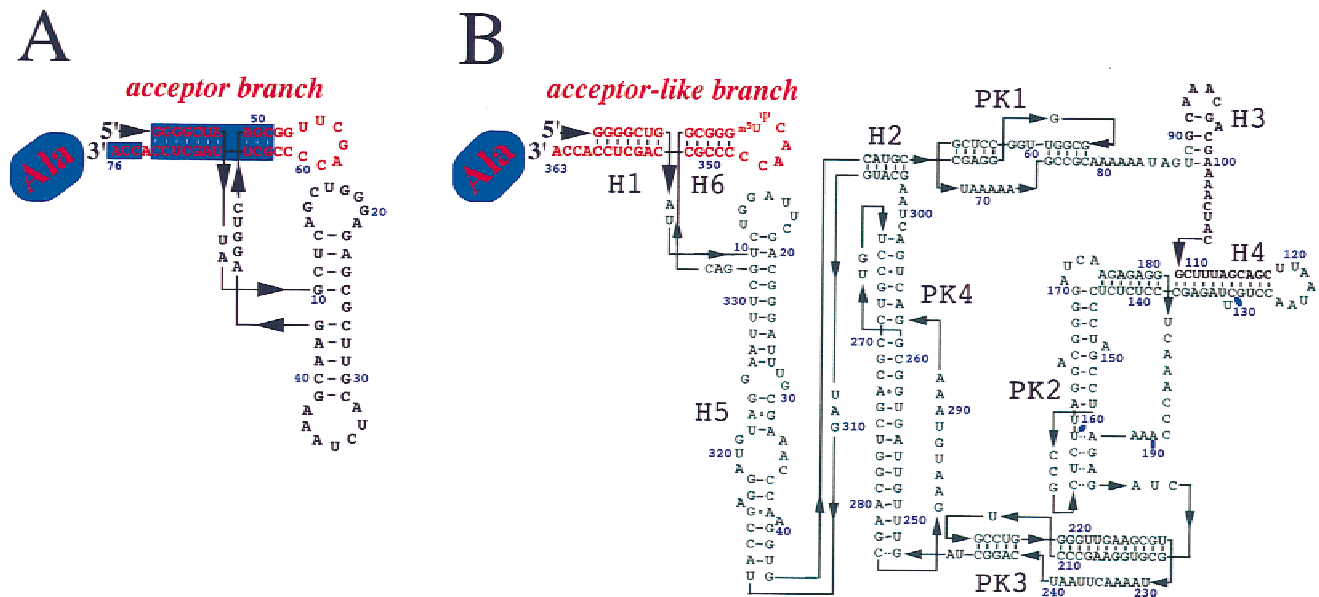

FIGURE 1. Comparison of tRNA^{Ala} (A) and tmRNA (B) secondary structures from *E. coli*. The acceptor and acceptor-like branches of the two RNAs are in red. Part of the tRNA that interacts with prokaryotic elongation factor Tu is boxed in blue. Nucleotides of tRNA^{Ala} are numbered according to Sprinzl et al. (1998). For *E. coli* tmRNA, the six RNA helices (H1–H6) and four RNA pseudoknots (PK1–PK4) are indicated. These two RNAs are chargeable at their 3' ends with alanine as indicated.

bound to aminoacyl-RNAs, protects the labile amino acid ester bond from spontaneous base-catalyzed hydrolysis. Results are displayed in Figure 2. As shown in panels A and B, *T. thermophilus* EF-Tu protects the deacylation of alanylated wild-type *E. coli* tmRNA similarly or even better than for alanylated tRNA^{Ala}. The calculated half-life ($t_{1/2}$) of the Ala-tmRNA ester bond is 17 min without EF-Tu-GTP and over 6 h in its presence (Table 1). Similar results are obtained with the alanylated tmRNA transcript deprived of posttranscriptional modifications (Fig. 2C), with a $t_{1/2}$ of 21 min of the ester bond without EF-Tu and of about 5 h when the factor is present (Table 1). Altogether, these results support an interaction between charged tmRNA and EF-Tu-GTP comparable to that occurring with tRNA^{Ala}. These measurements also show that the two modified bases in *E. coli* tmRNA are dispensable for the interaction, and that the additional sequence and intricate structure of tmRNA compared to canonical tRNAs do not prevent its recognition by EF-Tu-GTP.

Given these results, a charged minihelix derived from the tmRNA acceptor branch may also interact with EF-Tu-GTP, provided the remaining part of tmRNA structure does not contain any positive signals indispensable for the recognition. The 6 first bp of the acceptor stem in both *E. coli* tRNA^{Ala} and tmRNA are identical, so any putative negative signals could only be located within the 4 following bp. Thus, minihelices of 35 nt recapitulating the acceptor branch of tRNA^{Ala} and of tmRNA were prepared by *in vitro* transcription. They derive from the exact sequence of the two RNAs (Fig. 1), and were obtained after connection of nucleotides A₇ to A₄₉

in *E. coli* tRNA^{Ala} and G₇ to G₃₃₆ in *E. coli* tmRNA. The two alanylated RNA minisubstrates are both protected against deacylation in the presence of EF-Tu-GTP ($t_{1/2} = 114$ min for minihelix^{Ala} and $t_{1/2} = 172$ min for minihelix^{tmRNA}) albeit about twofold less than the full-length RNAs (Table 1 and Fig. 2D,E). This behavior is reminiscent of that observed with aspartylated minihelices that also display increased half-lives as compared to the whole molecule (Rudinger et al., 1994). These data suggest that in both tRNA and tmRNA, the connection of the acceptor branch to the remaining RNA structure introduces similar structural constraints that allow EF-Tu to bind.

The data presented here demonstrate the potential of tmRNA to be recognized by EF-Tu, and therefore likely rules out the requirement of a specialized factor for its delivery to the ribosome. This contrasts with other tRNAs bearing specialized functions in translation that make use of specific strategies for their delivery to the ribosome. Initiator tRNAs are brought to the ribosomal P-site by an initiation factor (Gualerzi & Pon, 1990) and selenocysteine tRNAs to the A-site by the SELB factor (Forchhammer et al., 1989, 1990). In these two cases, alternate strategies have been selected to preclude an interaction with EF-Tu-GTP. A C₁-A₇₂ mismatch in prokaryotic tRNA^{Met} (Seong & RajBhandary, 1987; Seong et al., 1989) and an antideterminant box at the 8–10-bp positions in *E. coli* tRNA^{Sec} (Rudinger et al., 1996) are the negative elements that preclude these tRNAs from being recognized by EF-Tu. To fulfill their “ribosomal gymnastic” in all eubacteria, with the exception of the alpha-proteobacteria (note in the tmRNA Website,

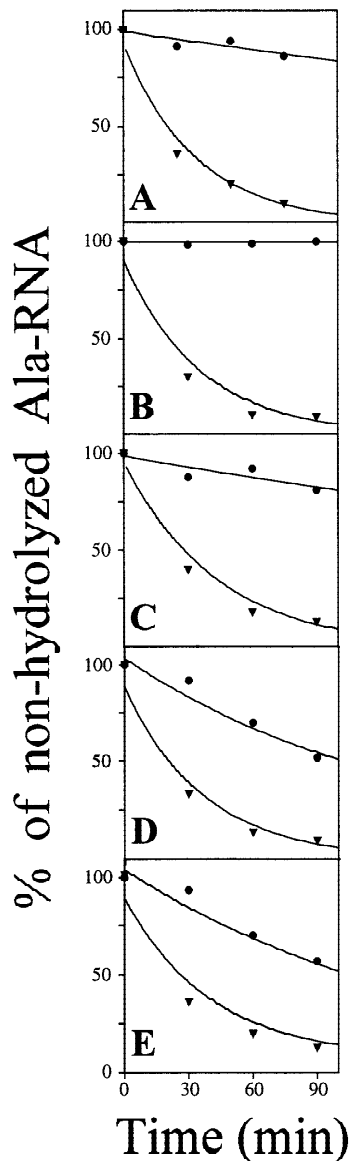

FIGURE 2. Rates of hydrolysis of the 3'-terminal alanine residue from five L-[C¹⁴]Ala-RNAs in the presence (●) and the absence (▼) of *Thermus thermophilus* EF-Tu-GTP. The concentration of labeled Ala-RNA is 0.5 μ M and that of EF-Tu-GTP is 2.5 μ M. **A:** alanylated *E. coli* tRNA^{Ala} transcript; **B:** overproduced tmRNA; **C:** tmRNA transcript; **D:** minihelix^{Ala}; and **E:** minihelix^{tmRNA}.

Williams, 1999; Felden et al., 1999), a tentative speculation is that tmRNAs arose from smaller functional RNA modules. These preexisting RNAs could have evolved from canonical tRNA^{Ala} (acceptor branch), mRNAs, and from a stretch of pseudoknots that are commonly found in noncoding RNAs. The tRNA-derived module has allowed tmRNAs to be recognized by EF-Tu, and this may have been sustained as an indispensable prerequisite for tmRNAs to be active in *trans*-translation.

MATERIALS AND METHODS

AlaRS from *E. coli* (Hill & Schimmel, 1989), T7 RNA polymerase (Becker et al., 1996), and EF-Tu-GDP from *T. ther-*

TABLE 1. Times required to hydrolyze 50% of the labile alanyl-ester bound ($t_{1/2}$) for the five RNAs in the presence and in the absence of EF-Tu-GTP. The values were deduced from the corresponding hydrolysis rates (Fig. 2).

RNAs	Half-lives of ala-RNAs (min)	
	-EF-Tu	+EF-Tu
tRNA ^{Ala} (transcript)	22	294
tmRNA (overproduced)	17	>360
tmRNA (transcript)	21	295
minihelix ^{Ala}	17	114
minihelix ^{tmRNA}	20	172

mophilus HB8 (Limmer et al., 1992) were purified from overproducing strains as described. Oligonucleotides were from NAPS GmbH (Göttingen, Germany), radioactive L-[C¹⁴] alanine (150 mCi/mmol) from Amersham (Les Ulis, France), restriction enzyme *Bst*N1 from New England Biolabs (Beverly, Massachusetts), and phosphoenolpyruvate, pyruvate kinase, and the ribonucleotides from Boehringer (Mannheim, Germany).

The overexpressed (>100-fold) *E. coli* tmRNA (Felden et al., 1997) and the corresponding T7 transcript (Felden et al., 1998) were produced and purified by established procedures. The tRNA^{Ala} transcript was prepared according to Frugier et al. (1993). Minihelices derived from *E. coli* tRNA^{Ala} and from *E. coli* tmRNA sequences were obtained by *in vitro* transcription of single-stranded DNA templates as described for aspartate minihelices (Frugier et al., 1994).

Alanylation of RNAs was performed in 100 mM Tris-HCl, pH 8.0, 10 mM KCl, 5 mM MgCl₂, 2 mM ATP, 10 mM dithioerythritol, 30 μ M L-[C¹⁴] alanine, and 2.8 μ M AlaRS for 45 min at 37 °C. All reactions were stopped by phenol extraction of the enzyme in the presence of sodium acetate at pH 4.5. The RNAs were ethanol precipitated, washed, and dried. Prior to that treatment, an aliquot of each sample was spotted on a 3MM Whatman filter and 5% trichloroacetic acid precipitated to measure the amount of alanylated RNA.

Hydrolysis-protection assays were conducted essentially as described (Pingould & Urbanke, 1980; Rudinger et al., 1994). For each experiment, ~50 pmol of the aminoacylated transcripts (taking into account their alanylation level) were dissolved in 50 mM Tris-HCl, pH 7.5, 50 mM KCl, and 10 mM MgCl₂ and incubated with a 5- and 10-fold excess of EF-Tu-GTP in a final volume of 100 μ L. Controls were carried out in parallel with EF-Tu replaced by 50 mM Tris-HCl, pH 7.5, 50 mM KCl, and 10 mM MgCl₂. After formation of the ternary complex "EF-Tu-GTP-alanylated RNA" (10 min incubation on ice), samples were further incubated at 37 °C to allow hydrolysis of the chemically unstable ester bond to proceed. Aliquots (20 μ L) were pulled out at 0, 30, 60, and 90 min and spotted onto 3MM Whatman filters. After trichloroacetic acid precipitation, the residual radioactivity was measured by liquid scintillation counting. Each set of experiments was repeated twice.

ACKNOWLEDGMENTS

We are indebted to M. Sprinzl (Bayreuth) for the generous gift of a clone of *T. thermophilus* EF-Tu and a sample of the

purified factor. We are also grateful to M. Frugier for purification of *E. coli* AlaRS and for providing the strain containing the tRNA^{Ala} gene. This work was partially supported by the European Commission in the frame of the Biotechnology Program (BIO-98-0189), the Centre National de la Recherche Scientifique, Université Louis Pasteur (Strasbourg). We are deeply grateful for the support of Prof. R.F. Gesteland and Dr. J.F. Atkins.

Manuscript accepted without revision May 27, 1999

REFERENCES

- Becker HD, Giegé R, Kern D. 1996. Identity of prokaryotic and eukaryotic tRNA^{ASP} for aminoacylation by aspartyl-tRNA synthetase from *Thermus thermophilus*. *Biochemistry* 35:7447–7458.
- Felden B, Himeno H, Muto A, Atkins JF, Gesteland RF. 1996. Structural organization of *Escherichia coli* tmRNA. *Biochimie* 78:979–983.
- Felden B, Himeno H, Muto A, McCutcheon JP, Atkins JF, Gesteland RF. 1997. Probing the structure of the *Escherichia coli* 10Sa RNA (tmRNA). *RNA* 3:89–103.
- Felden B, Hanawa K, Atkins JF, Himeno H, Muto A, Gesteland RF, McCloskey JA, Crain PF. 1998. Presence and location of modified nucleotides in *Escherichia coli* tmRNA: Structural mimicry with tRNA acceptor branches. *EMBO J* 17:3188–3196.
- Felden B, Gesteland RF, Atkins JF. 1999. Eubacterial tmRNAs: Everywhere except the Alpha-Proteobacteria? *Biochim Biophys Acta* 1446:145–148.
- Forchhammer K, Leinfelder W, Böck A. 1989. Identification of a novel translation factor necessary for the incorporation of selenocysteine into protein. *Nature* 342:453–456.
- Forchhammer K, Ruecknagel K-P, Böck A. 1990. Purification and biochemical characterization of SELB, a translation factor involved in selenoprotein synthesis. *J Biol Chem* 265:9346–9350.
- Frugier M, Florentz C, Schimmel P, Giegé R. 1993. Triple aminoacylation specificity of a chimerized transfer RNA. *Biochemistry* 32:14053–14061.
- Frugier M, Florentz C, Giegé R. 1994. Efficient aminoacylation of resected RNA helices by class II aspartyl-tRNA synthetases. *Biochemistry* 33:9912–9921.
- Gualerzi CO, Pon CL. 1990. Initiation of mRNA translation in prokaryotes. *Biochemistry* 29:5881–5889.
- Hickerson RP, Watkins-Sims CD, Burrows CJ, Atkins JF, Gesteland RF, Felden B. 1998. A nickel complex cleaves uridines in folded RNA structures: Application to *E. coli* tmRNA and related engineered molecules. *J Mol Biol* 279:577–587.
- Hill K, Schimmel P. 1989. Evidence that the 3'-end of a transfer RNA binds to a site in the adenylate synthesis domain of an aminoacyl-tRNA synthetase. *Biochemistry* 28:2577–2586.
- Himeno H, Sato M, Tadaki T, Fukushima M, Ushida C, Muto A. 1997. In vitro *trans* translation mediated by alanine-charged 10Sa RNA. *J Mol Biol* 268:803–808.
- Hou Y-M, Schimmel P. 1988. A simple structural feature is a major determinant of the identity of a transfer RNA. *Nature* 333:140–145.
- Keiler KC, Waller PRH, Sauer RT. 1996. Role of a peptide tagging system in degradation of proteins synthesized from damaged messenger RNA. *Science* 271:990–993.
- Komine Y, Kitabatake M, Yokogawa T, Nishikawa K. 1994. A tRNA-like structure is present in 10Sa RNA, a small stable RNA from *Escherichia coli*. *Proc Natl Acad Sci USA* 91:9223–9227.
- Komine Y, Kitabatake M, Inokuchi H. 1996. 10Sa RNA is associated with 70S ribosome particles in *Escherichia coli*. *J Biochem (Tokyo)* 119:463–467.
- Limmer S, Reiser COA, Schirmer NK, Grillenbeck N, Sprinzl M. 1992. Nucleotide binding and GTP hydrolysis by elongation factor Tu from *Thermus thermophilus* as monitored by proton NMR. *Biochemistry* 31:2970–2977.
- Makarov EM, Apirion D. 1992. 10Sa RNA: Processing by and inhibition of RNase III. *Biochem Int* 26:1115–1124.
- McClain WH, Foss K. 1988. Changing the identity of a tRNA by introducing a G-U wobble pair near the 3' acceptor end. *Science* 240:793–796.
- Muto A, Ushida C, Himeno H. 1998. A bacterial RNA that functions as both a tRNA and an mRNA. *Trends Biochem Sci* 23:25–29.
- Nissen P, Kjeldgaard M, Thirup S, Polekhina G, Reshetnikova L, Clark BFC, Nyborg J. 1995. Crystal structure of the ternary complex of Phe-tRNA^{Phe}, EF-Tu, and a GTP analog. *Science* 270:1464–1472.
- Nissen P, Thirup S, Kjeldgaard M, Nyborg J. 1999. The crystal structure of Cys-tRNA^{Cys}-EF-Tu-GDPNP reveals general and specific features in the ternary complex and in tRNA. *Structure* 7:143–156.
- Pingould A, Urbanke C. 1980. Aminoacyl transfer ribonucleic acid binding site of the bacterial elongation factor Tu. *Biochemistry* 19:2108–2112.
- Rudinger J, Blechschmidt B, Ribeiro S, Sprinzl M. 1994. Minimalist aminoacylated RNAs as efficient substrates for elongation factor Tu. *Biochemistry* 33:5682–5688.
- Rudinger J, Hillenbrandt R, Sprinzl M, Giegé R. 1996. Antideterminants present in minihelix^{Sec} hinder its recognition by prokaryotic elongation factor Tu. *EMBO J* 15:650–657.
- Seong BL, RajBhandary UL. 1987. Mutants of *Escherichia coli* formylmethionine tRNA: A single base change enables initiator tRNA to act as an elongator in vitro. *Proc Natl Acad Sci USA* 84:8859–8863.
- Seong BL, Lee CP, RajBhandary UL. 1989. Suppression of amber codons in vivo as evidence that mutants derived from *Escherichia coli* initiator tRNA can act as the step of elongation in protein synthesis. *J Biol Chem* 264:6504–6508.
- Sprinzl M, Horn C, Brown M, Ioudovitch A, Steinberg S. 1998. Compilation of tRNA sequences and sequences of tRNA genes. *Nucleic Acids Res* 26:148–153.
- Srivastava RK, Miczak A, Apirion D. 1990. Maturation of precursor 10Sa RNA in *Escherichia coli* is a two-step process: The first reaction is catalyzed by RNase III in presence of Mn²⁺. *Biochimie* 72:791–802.
- Tu GF, Reid GE, Zhang JG, Moritz RL, Simpson RJ. 1995. C-terminal extension of truncated recombinant proteins in *Escherichia coli* with a 10Sa RNA decapeptide. *J Biol Chem* 270:9322–9326.
- Ushida C, Himeno H, Watanabe T, Muto A. 1994. tRNA-like structures in 10Sa RNAs of *Mycoplasma capricolum* and *Bacillus subtilis*. *Nucleic Acids Res* 22:3392–3396.
- Williams KP, Bartel DP. 1996. Phylogenetic analysis of tmRNA secondary structure. *RNA* 2:1306–1310.
- Williams KP. 1999. The tmRNA Website. *Nucleic Acids Res* 27:165–166.
- Withey J, Friedman D. 1999. Analysis of the role of *trans*-translation in the requirement of tmRNA for *imm*^{P22} growth in *Escherichia coli*. *J Bacteriol* 181:2148–2157.