

A NEW AUTOMATED EXTRACTION SYSTEM FOR ^{14}C MEASUREMENT FOR ATMOSPHERIC CO_2

Jocelyn C Turnbull^{1,2} • Scott J Lehman² • Stephen Morgan² • Chad Wolak²

ABSTRACT. The radiocarbon content of atmospheric CO_2 ($\Delta^{14}\text{CO}_2$) has long been of interest to atmospheric and Earth system researchers. Recent improvements in ^{14}C measurement precision and reduction in sample size requirements have now made it possible to measure $\Delta^{14}\text{CO}_2$ within existing trace gas sampling networks, most notably as a method to quantify recently added fossil-fuel-derived CO_2 in the atmosphere. At INSTAAR, in collaboration with NOAA/ESRL, ~600 atmospheric samples from around the globe are prepared each year, and that number is anticipated to grow in connection with various monitoring and data assimilation efforts. To accommodate the growing demand and reduce per sample costs, we developed an automated extraction system to quantitatively isolate CO_2 from whole air for AMS ^{14}C analysis. Twenty samples can be extracted in 1 fully automated run, taking 10–12 hr to complete and requiring only about 1 hr of operator time, a substantial improvement over the manual extraction system. CO_2 is extracted cryogenically by flowing the whole air over a liquid nitrogen trap, after first removing water in a trap at -85°C . Large volume vacuum lines are used to extract ~30 μmol of CO_2 in less than 10 min, keeping contamination from leaks to a minimum and allowing rapid processing and greater throughput. $\delta^{13}\text{C}$ measurements on the resultant CO_2 demonstrate that extraction is quantitative, and extractions of ^{14}C -free air show that no significant modern contamination occurs. Replicate analyses of standard materials indicate that both mean values and precision are comparable to those for the manual extraction system.

INTRODUCTION

Measurements of the radiocarbon content of carbon dioxide ($\Delta^{14}\text{CO}_2$) are recognized as the most promising method for independently and objectively constraining fossil fuel CO_2 emissions (e.g. Meijer et al. 1996; Levin et al. 2003, 2007; Turnbull et al. 2006, 2009; Graven et al. 2009), and have numerous other applications, including understanding ocean and terrestrial biospheric carbon exchange with the atmosphere, monitoring of carbon sequestration projects, and quantifying emissions of various anthropogenic trace gases associated with urban and industrial activity.

Beginning in 2003, $\Delta^{14}\text{CO}_2$ measurements have been made in samples from the NOAA/ESRL Cooperative Air Sampling Network, which collects and measures ~20,000 discrete air samples each year, for a variety of greenhouse and related gases, including CO_2 , CO , CH_4 , N_2O , H_2 , SF_6 , $\delta^{13}\text{C}$, and $\delta^{18}\text{O}$ of CO_2 ; $\delta^{13}\text{C}$ and δD of CH_4 ; and a suite of hydrocarbons and halocarbons (Trolrier et al. 1996; Miller et al. 2002; Tans and Conway 2005). Samples are collected from sites worldwide, mostly at the surface, but increasingly from aircraft profiles and tall towers. A subset of ~600 of these samples is extracted for $\Delta^{14}\text{CO}_2$ measurement each year and ~400 samples per year are measured, all limited by processing time, availability of accelerator mass spectrometry (AMS) measurement time, and funding. Samples are prepared at the University of Colorado INSTAAR Laboratory for AMS Radiocarbon Preparation and Research, with several different AMS facilities used for the measurement. Initial samples were measured at the Rafter Radiocarbon Laboratory (Lower Hutt, New Zealand), while more recently measurements have been performed at the Keck Carbon Cycle Facility at the University of California, Irvine (California, USA). Careful sample preparation procedures and high count AMS measurement have resulted in precision of ~2‰ on samples of 2 L of whole air (Turnbull et al. 2007), with the relatively small sample size allowing use of existing samples collected from the NOAA/ESRL network. The sample processing involves quantitative, non-fractionating, cryogenic extraction of CO_2 from the whole-air samples, followed by standard graph-

¹NOAA Earth System Research Laboratory, 325 Broadway, Boulder, Colorado 80303, USA. Corresponding author. Email: jocelyn.turnbull@noaa.gov.

²University of Colorado at Boulder, 1560 30th St, Boulder, Colorado 80309, USA.

itization procedures. To date, the CO₂ extraction has been performed manually, taking about 1 hr per sample, and requiring operator attention for most of that time.

There is substantial interest in expanding the number of $\Delta^{14}\text{CO}_2$ measurements within the NOAA/ESRL sampling network, and reduction in both processing time and costs will be necessary to achieve this. Here, we describe an automated Carbon cycle Radiocarbon EXtraction system (CRex) for extraction of CO₂ from whole air, which allows us process up to 20 authentic or control samples in each 10–12 hr run, while maintaining rigorous standards of quality control.

Description of the CRex System

CRex follows a design similar to that of our manual CO₂ extraction system (Turnbull et al. 2007), but is fully automated to allow autonomous extraction. The fully automated system consists of 3 main sections: a sample input manifold; an extraction manifold; and a storage manifold (Figure 1).

The sample input manifold is designed for the 2 main flask types used in the sampling network as well as standard cylinders. By using different connections at the ports, other flask types can also be accommodated. Samples from surface sites are collected in two 2.5-L glass flasks, filled simultaneously (Tans and Conway 2005). Each flask is analyzed for greenhouse gas mixing ratios and a subset of stable isotope and hydrocarbon or halocarbon measurements. Approximately 1 L (STP) of air remains in each flask after these analyses, and air from both flasks is then combined to provide a single 2-L sample containing ~0.4 mg of carbon, quite sufficient to obtain ¹⁴C measurements of 2‰ precision. At a few select sites, we collect an additional pair of flasks for replicate ¹⁴C measurement and quality control. Samples from aircraft and at tall towers are collected in automated Programmable Flask Packages (PFs), each containing twelve 700-mL flasks pressurized to 1900 Torr (2.5 atm). When ¹⁴C measurement is desired, 2 flasks are filled at each sampling time/location; following the other analyses, the 2 flasks are combined for ¹⁴C measurement.

Numerous control samples are also prepared in each extraction run and AMS measurement wheel, in order to monitor data quality. Aliquots are extracted directly from large high-pressure cylinders of the control materials. A cylinder of synthetic ¹⁴C-free air (“dead air”) is used as a process blank. To date, we have used a single cylinder of ambient air collected at Niwot Ridge, Colorado, in November 2002 (“NWT_{std}”) in order to evaluate the long-term measurement repeatability, as described by Turnbull et al. (2007). Two additional control cylinders, one of ambient air (“NWT3”) and another with slightly lower than ambient $\Delta^{14}\text{C}$ value (“NWT4”), are currently being phased in to augment and extend the lifespan of NWT_{std}.

The sample input manifold can accommodate up to 7 flask pairs, 4 PFs, and 4 cylinders at any given time (multiple samples are extracted from each PFP and from cylinders). Before extraction begins, all connections are evacuated and tested for leakage. The stainless steel tubing connecting the standard cylinders to the sample input manifold is flushed several times to remove residual room air, and the valves on the glass flasks are opened. Since the PFP flask valves are automatically controlled, they are left closed at this stage.

During extraction, valves VP3 and VP4 (Figure 1) and the appropriate sample input valve (VII–VII2) are opened and sample air is gradually pulled through the line by the rotary vane pump. Water is removed in a 3-loop trap containing glass beads, immersed in a cryobath of ethanol at –85 °C. The water trap is designed to ensure complete removal of water from all 20 samples without drying between samples but is removed and dried between runs. Before starting each run, air must be evacuated from the trap before immersion in the cryobath, as small amounts of room air can otherwise be trapped in the ice matrix, resulting in poor ¹⁴C blanks. CO₂ is frozen out during extraction by

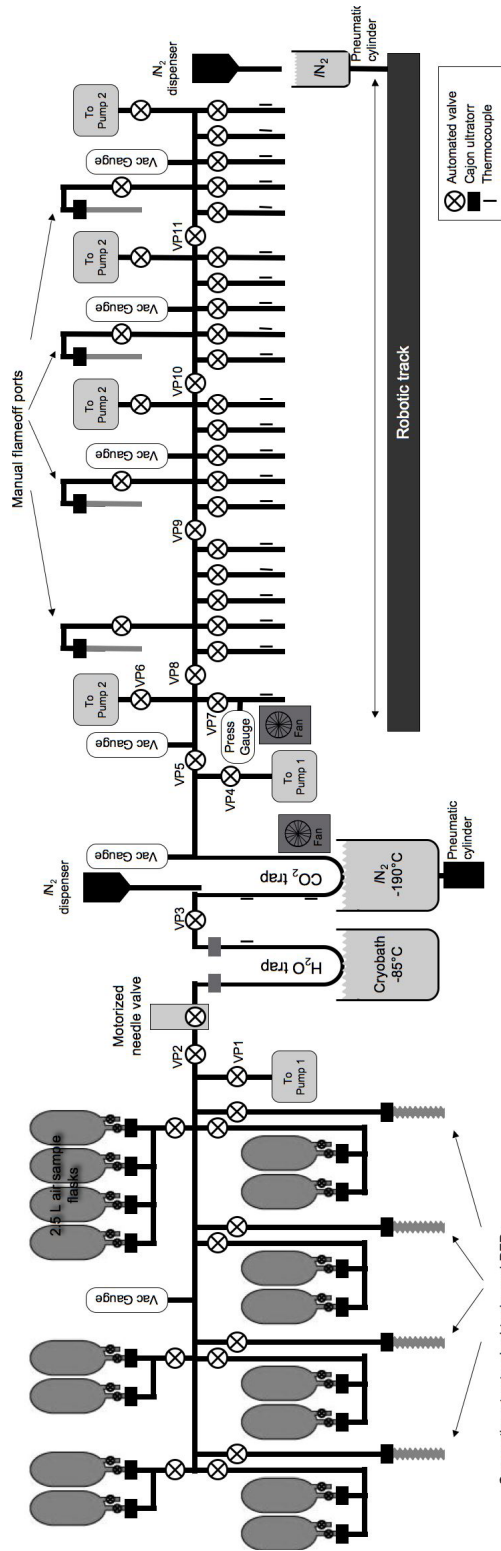

Figure 1 Schematic of CRex, showing the 3 main components of the system: sample input manifold, extraction manifold, and storage manifold (left to right).

immersing the 3-loop CO₂ trap in liquid nitrogen (*N*₂). A pneumatic cylinder automatically raises the *N*₂ dewar, thermocouples attached to the trap monitor the *N*₂ level, and *N*₂ is automatically dispensed when the level falls. The motorized needle valve is automatically adjusted to keep the pressure in the CO₂ trap between 3.5 and 4.0 Torr (and then dropping to below 1 Torr at the end of flask and PFP extractions), ensuring complete freezing of CO₂ without also capturing CH₄, CO, or O₂. N₂O, with a similar freezing point to CO₂, is also collected but does not interfere with the Δ¹⁴C_{O₂ measurement. The needle valve is used instead of a flow controller to give consistent flow rates for the large range of back pressures encountered (from 1800 Torr to near vacuum).}

Flask and PFP samples are extracted completely (to a nominal back pressure of 1 Torr), whereas for cylinders a set extraction time is used. Once extraction is complete, the frozen CO₂ is isolated in the CO₂ trap, the *N*₂ dewar is lowered, and a small fan is used to bring the trap rapidly to room temperature, subliming the CO₂.

Large diameter (5/8", 1.5 cm) glass tubing is used throughout to allow large flow rates of ~350 standard cubic centimeters per minute (sccm) (as discussed in more detail below), permitting complete CO₂ extraction for a single sample in 6–10 min. The rapid extraction maximizes sample throughput and reduces contamination from slow leaks in the system.

Once extraction is complete, the sample is warmed to room temperature in the CO₂ trap and then cryogenically transferred to a known-volume cold finger containing a pressure transducer. To achieve this, *N*₂ is dispensed into a small dewar, and then brought to the cold finger by a robotic track and pneumatic cylinder combination. A thermocouple on the cold finger ensures that sufficient *N*₂ is in the dewar. After the sample is completely transferred (as measured by the residual pressure), any non-condensable gases are pumped away, and the CO₂ allowed to sublime, utilizing a small fan to speed warming. The CO₂ pressure (and, by corollary, sample size) is recorded, and the sample is then cryogenically transferred to one of 20 storage vessels, using the same *N*₂ delivery system.

All samples are stored in closed Pyrex[®] storage vessels until the run is complete. Samples are then manually transferred to Pyrex tubes and sealed with a gas torch. The Pyrex tubes are prebaked at 450 °C for several hours before use. The 20 storage vessels are divided into 4 isolated banks of 5 vessels, each of which contains a port for connecting Pyrex flame-sealed tubes, so that 4 samples (1 from each bank) can be cryogenically transferred and sealed at the same time, reducing the operator time needed. The extracted CO₂ can be stored indefinitely in the sealed Pyrex tubes; occasional faulty tubes are easily detected by the presence of air in the tube at the time of graphitization. Air samples are typically stored for a few months, allowing the compilation of a full AMS measurement wheel (~25 samples) from a single site before graphitization and measurement. Aliquots of the control materials are extracted and stored at the same time as samples to ensure that any problems with the extraction procedure are identified.

The entire process is controlled using LabVIEW software, customized for our application. LabVIEW interfaces with the laboratory FilemakerPro[®] database, documenting details of each extraction, including the sample identification, input port and storage vessel used, extraction time, sample size, and non-condensable pressures at various stages. Every step of system operation is logged in a text file in case troubleshooting should be necessary.

All valve bodies and stems are glass with Viton[®] O-rings, and are pneumatically actuated using 60-psi air and 5-volt solenoids. We use 2 similar valve types, made by Glass Expansion Inc. (Australia) and custom valves from Allen Scientific Glass (Colorado, USA). *N*₂ is dispensed from a large tank, using solenoid-controlled cryogenic valves. A single 160-L *N*₂ tank lasts 1 or 2 runs. Pressure and

vacuum are recorded using Silicon Microstructures SM5812 and MKS Pirani 925C gauges, respectively. The motorized needle valve consists of a Swagelok® M series needle valve (10 revolutions from fully closed to fully open) attached to a custom motor actuator from ETI Systems (California, USA), controlled by 0–10 Volt signals. N_2 is brought to the CO_2 trap by raising and lowering a dewar on a pneumatic cylinder, and dispensing N_2 into the raised dewar. For the storage vessels, 2 stacked pneumatic cylinders are used to raise the dewar to a standard and “top-up” height. A linear robotic track (Techno-Isel) moves the dewar to each storage vessel position, and is controlled using custom LabVIEW software provided by the manufacturer. Two rotary vane vacuum pumps are used so that extraction of a second sample can begin while the first is being quantified and stored.

The extraction process is fully automated, with the operator being required to load the samples and standards prior to starting each run and manually seal the extracted CO_2 into flame-off tubes when the run is complete. Currently, a run of 20 samples takes 10–12 hr, requiring ~1 hr of operator time. By contrast, our manual extraction system requires the operator to monitor a 1-hr-long extraction process for each sample.

Quality Control and Initial Results

High-precision measurement of $\Delta^{14}CO_2$ requires close attention to all aspects of sample preparation and measurement. Several aliquots from our NWT_{std} control cylinder and a synthetic dead-air process blank are extracted and measured concurrently with every set of samples, providing for ongoing assessment of the long-term measurement repeatability, as well as intercomparability between the manual and automated systems. In addition, a suite of initial $\delta^{13}C$ and $\Delta^{14}C$ measurements were performed to test for possible sources of contamination or fractionation in the new CRex system. The $\delta^{13}C$ measurements were obtained in the neighboring INSTAAR Stable Isotope Laboratory by dual-inlet IRMS, as used routinely for high-precision ($\pm 0.01\%$) measurements of $\delta^{13}CO_2$ in air from the NOAA/ESRL Global Air Sampling Network (Trolier et al. 1996).

Our synthetic dead-air cylinder was purchased and prepared in 2002, and over time, has become slightly contaminated with $^{14}CO_2$, apparently either from diffusion through the cylinder valve or from outgassing of hydrocarbons from the cylinder walls. In 2002, this cylinder had a fraction modern of 0.002 (50,000 BP), but has gradually increased to a fraction modern of 0.004 (45,000 BP); ^{14}C contamination of this amount is too small to detect in the related $\delta^{13}CO_2$ value or CO_2 mixing ratio. In the case of modern atmospheric samples, where the blank correction is extremely small, the increasing blank value changes $\Delta^{14}CO_2$ by $<0.2\%$ (for $\Delta^{14}CO_2$ of -100 to $+100\%$). This is not of significant concern relative to other measurement uncertainties, and it is still possible to discern any modern contamination associated with specific extraction conditions. Nonetheless, this cylinder is being replaced with a new cylinder of dead air, using a cleaner cylinder and valve system. No such contamination is detectable in NWT_{std} , in part because it is difficult to resolve minor contamination in modern materials, but also likely because NWT_{std} was collected in a higher quality cylinder.

A more serious problem was encountered in our initial extraction experiments, which showed evidence of contamination, visible as highly variable $\delta^{13}C$ values in separate extraction aliquots from the same parent cylinder. Measured values were initially close to the expected value (determined previously by extraction in-line with the dual-inlet IRMS), but gradually increased by up to 1‰ during each 2-min ionization and data acquisition cycle, indicative of organic contamination in the samples. Further testing revealed that the source was PVC vacuum tubing used to connect the glass line to the rotary vane pump. The problem was solved by replacing the PVC tubing with stainless steel crinkle tubing and adding a N_2 trap proximal to the vacuum pump.

The large diameter tubing used in CRex allows for substantially higher flow rates than our manual system. To ensure that all CO₂ was extracted without fractionation, we compared $\delta^{13}\text{C}$ results for individual CRex extraction aliquots with measurements for multiple aliquots extracted from the same NWT_{std} cylinder directly in-line with the IRMS. All flow rates tested, except the lowest flow rate of 80 sccm, were within the 1- σ uncertainty range of the nominal cylinder value for NWT_{std} of $-8.02 \pm 0.03\text{‰}$, indicating that no significant fractionation occurred during extraction (Figure 2). The slightly lower value for the 80-sccm flow rate ($-8.10 \pm 0.02\text{‰}$) is surprising. It is possible that the difference is due to the fact that the 80-sccm aliquots were extracted for significantly longer (20–25 min) than the higher flow rate samples (4–8 min) in order to obtain sufficient CO₂ for the stable isotopic measurement, and that small leaks in the tubing to the tank influenced the observed $\delta^{13}\text{C}$. In any case, we chose a flow rate of 350 sccm for all remaining tests, and adopted this flow rate as standard extraction procedure.

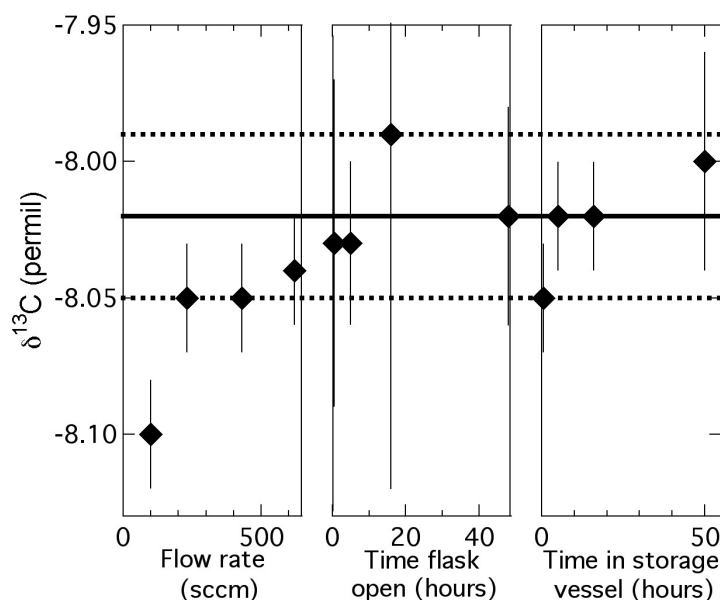

Figure 2 $\delta^{13}\text{C}$ of NWT_{std} for various tests. Left panel: $\delta^{13}\text{C}$ for extractions at various flow rates. Middle panel: Aliquots were stored in flasks, connected to the line, with the flask valve open for the indicated time before extracting at 350 sccm. Right panel: Aliquots were extracted directly from the standard cylinder at 350 sccm, then stored in the storage vessel for the indicated time. The thick solid and dashed lines show the mean and standard deviation of multiple aliquots from the same cylinder, but extracted using the Stable Isotope Laboratory online extraction system and injected directly into the mass spectrometer.

Aliquots of dead air were extracted directly following extractions of NWT_{std}, and measured for ¹⁴C content, to test for possible memory effects in the extraction system, particularly from the water trap, which remains in place during the entire run. These tests gave similar results to extractions performed on the manual line (during the same time period) and to “standard” extractions on CRex, whereby a series of dead-air aliquots were extracted under standard conditions, but with the line and trap cleaned before the run (Figure 3). We did note, however, that under conditions when the water trap was not evacuated before being placed into the cryobath (i.e. any water from the room air was allowed to freeze into the trap, possibly enclosing CO₂ from room air), the dead-air values were

somewhat elevated. Evacuating the water trap before immersion in the cryobath (“standard” extraction) eliminated this problem.

Manually valved flasks (but not PFPs) must be evacuated to the flask valve, and then left on the line with the flask valve open until extraction is performed, potentially allowing leakage at the Ultratorr flask connection. $\delta^{13}\text{C}$ and ^{14}C blanks show, however, that after 2 days (vs. 10-hr typical runtime), no significant contamination or fractionation occurs (Figures 2 and 3). During the final stages of extraction, the flask sample flow rate must drop well below the standard 350-sccm flow rate, as the flask pressure drops to 1 Torr. The reduction in $\delta^{13}\text{C}$ observed in the 80-sccm tests is not apparent here, likely because the low flow rate occurs only for a short portion of the total extraction time.

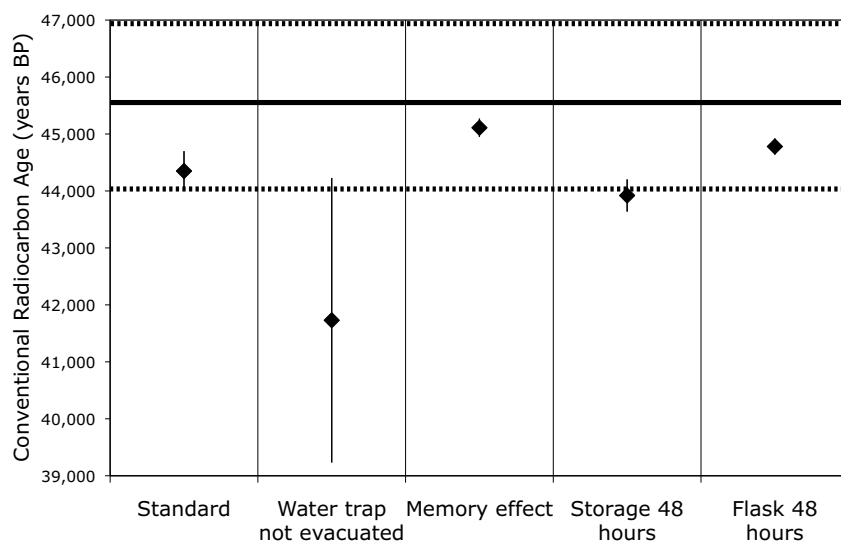

Figure 3 AMS ^{14}C measurements of a synthetic process blank (“dead air” discussed in the text) under differing extraction conditions, with error bars representing the variability amongst multiple measurements under the same conditions. The thick solid and dashed lines indicate the mean background and uncertainty in aliquots extracted on the manual system in 2008 and 2009. Symbols are for aliquots extracted on CRex under various conditions, described in detail in the text.

The valved storage vessels are also a source of potential leakage, but no detectable fractionation occurred when the samples were stored in the storage vessels for up to 3 days; they are typically stored less than 24 hr before transfer to flame-sealed tubes (Figure 2, right panel). Process blanks stored for 48 hr showed slightly elevated activity, with an age of $44,000 \pm 300$ BP versus $45,500 \pm 1500$ BP for manually extracted samples. This equates to a modern contamination of 0.07%. For near-ambient samples, with $\Delta^{14}\text{CO}_2$ in the range of -100 to $+100\text{‰}$, the effect of this amount of modern contamination is a change in $\Delta^{14}\text{CO}_2$ of $<0.1\text{‰}$, which is insignificant relative to other measurement uncertainties. It does suggest, however, that samples should be transferred to flame-sealed tubes as promptly as is practical.

Figure 4 and Table 1 show measured NWT_{std} values for manual extractions (ongoing measurements since 2003) and CRex extractions. All were graphitized in the same manner and measured at the UC Irvine Keck Carbon Cycle AMS Facility. The CRex extractions agree very well with the manual values measured in the same measurement wheels (Table 1), and the offset from the long-term mean of the manual values is likely related to known wheel-to-wheel variability in AMS measurement (Graven et al. 2007; Turnbull et al. 2007) as well as a possible drift in the tank itself over time. The

repeatability is calculated from the scatter of all measurements, and is 2.0‰ at 1 σ for all manual extractions since 2003. The contributions to this uncertainty from AMS measurement, within-wheel variability (representing the combined contribution from extraction and graphitization), and wheel-to-wheel variability are 1.8‰, 0.6‰, and 0.8‰, respectively, using the methodology described by Graven et al. (2007). The 1- σ repeatability of the CRex measurements is, so far, slightly better than for manual extractions, at 1.4‰. This value approaches the counting statistical limit of the AMS measurement (1.3‰ for the 750,000 ^{14}C counts obtained for each sample), and implies that the CO_2 extraction procedure does not appreciably contribute to uncertainty in measurement of $\Delta^{14}\text{CO}_2$, even at high precision.

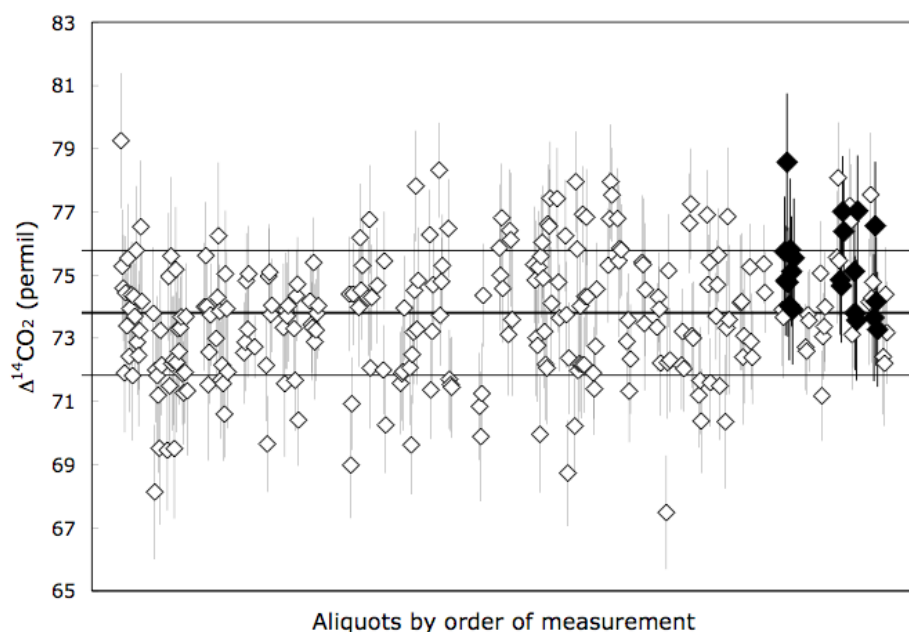

Figure 4 $\Delta^{14}\text{C}$ of NWT_{std} . Each aliquot was extracted individually either on the manual extraction system or on CRex. Manual extractions have been performed in every measurement wheel since 2003, CRex measurements are from 4 wheels in 2009. Error bars are the 1- σ uncertainty based on counting statistics. Thick and thin lines indicate the mean value and 1- σ repeatability of all manual measurements of NWT_{std} .

Table 1 Comparison of NWT_{std} measurements made using CRex and the manual extraction line. The numbers in parentheses indicate the number of targets in each data set, used to calculate the mean and repeatability. “All measurements” includes all NWT_{std} targets measured since 2003; “All wheels with CRex samples” considers only the targets in the 4 wheels in which CRex samples have been measured.

	All measurements	All wheels with CRex samples	Wheel 319	Wheel 326	Wheel 327	Wheel 329
Manual	73.8 ± 2.0 (295)	75.2 ± 2.2 (14)	73.8 ± 0.2 (2)	75.8 ± 1.7 (4)	75.2 ± 2.0 (4)	75.2 ± 1.6 (4)
CRex	75.2 ± 1.4 (21)	75.2 ± 1.4 (21)	75.4 ± 1.4 (9)	75.7 ± 1.2 (4)	74.9 ± 1.6 (4)	74.4 ± 1.5 (4)
Difference	-1.4	0.0	-1.6	0.1	0.3	0.8

CONCLUSIONS

The CRex automated extraction system for CO_2 from air allows significantly higher throughput of samples for ^{14}C measurement than previous manual systems. The procedure is non-fractionating, and no detectable contamination occurs. Initial measurements indicate that the repeatability of samples extracted on CRex is comparable, or possibly better than, that of manually extracted samples.

ACKNOWLEDGMENTS

John Southon at the UC Irvine Keck Carbon Cycle AMS Facility provided the ^{14}C measurements, along with much valuable input and discussion. Sylvia Michel and Bruce Vaughn of the INSTAAR Stable Isotope Laboratory made the $\delta^{13}\text{C}$ measurements and provided insightful guidance on automation. Funding for this project was from the Graduate School of the University of Colorado and from NOAA/ESRL (John Miller). Standard materials and some equipment were supplied by the NOAA/ESRL Carbon Cycle Greenhouse Gas group.

REFERENCES

- Graven HD, Guilderson TP, Keeling RF. 2007. Methods for high-precision ^{14}C AMS measurement of atmospheric CO_2 at LLNL. *Radiocarbon* 49(2):349–56.
- Graven HD, Stephens BB, Guilderson TP, Campos TL, Schimel DS, Campbell JE, Keeling RF. 2009. Vertical profiles of biospheric and fossil fuel-derived CO_2 and fossil fuel CO_2 : CO ratios from airborne measurements of ^{14}C , CO_2 and CO above Colorado, USA. *Tellus B* 61(3):536–46.
- Levin I, Kromer B, Schmidt M, Sartorius H. 2003. A novel approach for independent budgeting of fossil fuel CO_2 over Europe by $^{14}\text{CO}_2$ observations. *Geophysical Research Letters* 30(23):2194.
- Levin I, Hammer S, Kromer B, Meinhardt F. 2007. Radiocarbon observations in atmospheric CO_2 : determining fossil fuel CO_2 over Europe using Jungfraujoch observations as background. *Science of the Total Environment* 391(2–3):211–6.
- Meijer HAJ, Smid HM, Perez E, Keizer MG. 1996. Isotopic characterisation of anthropogenic CO_2 emissions using isotopic and radiocarbon analysis. *Physical Chemistry of the Earth* 21(5–6):483–7.
- Miller JB, Mack KA, Dissly R, White JWC, Dlugokencky EJ, Tans PP. 2002. Development of analytical methods and measurements of $^{13}\text{C}/^{12}\text{C}$ in atmospheric CH_4 from the NOAA Climate Monitoring and Diagnostics Laboratory Global Air Sampling Network. *Journal of Geophysical Research* 107(D13):4178.
- Tans PP, Conway TJ. 2005. Monthly atmospheric CO_2 mixing ratios from the NOAA CMDL Carbon Cycle Cooperative Global Air Sampling Network, 1968–2002. In: *Trends: A Compendium of Data on Global Change*. Carbon Dioxide Information Analysis Center, Oak Ridge National Laboratory, US Department of Energy, Oak Ridge, Tennessee, USA.
- Trolier M, White JWC, Tans PP, Masarie KA, Gemery PA. 1996. Monitoring the isotopic composition of atmospheric CO_2 : measurements from the NOAA global air sampling network. *Journal of Geophysical Research* 101(D20):25,897–916.
- Turnbull JC, Miller JB, Lehman SJ, Tans PP, Sparks RJ, Southon J. 2006. Comparison of $^{14}\text{CO}_2$, CO and SF_6 as tracers for determination of recently added fossil fuel CO_2 in the atmosphere and implications for biological CO_2 exchange. *Geophysical Research Letters* 33: L01817, doi:10.1029/2005GL024213.
- Turnbull JC, Lehman SJ, Miller JB, Sparks RJ, Southon JR, Tans PP. 2007. A new high precision $^{14}\text{CO}_2$ time series for North American continental air. *Journal of Geophysical Research* 112: D11310, doi:10.1029/2006JD008184.
- Turnbull JC, Miller JB, Lehman SJ, Hurst DF, Peters W, Tans PP, Southon JR, Montzka SA, Elkins JW, Mondeel DJ, Romashkin PA, Elansky NF, Shkorokhod A. 2009. Spatial distribution of $\Delta^{14}\text{CO}_2$ across Eurasia: measurements from the TROICA-8 expedition. *Atmospheric Chemistry and Physics* 9:175–87.