

The Journal of
**THE ROYAL
AERONAUTICAL
SOCIETY**



CONTENTS

APRIL 1951

CLEAR AIR TURBULENCE OVER EUROPE

*G. S. HISLOP, Ph.D., B.Sc., A.R.T.C.,
A.F.R.Ae.S., M.I.Mech.E.*

MEASUREMENT OF JET ENGINE THRUST

BENGT JAKOBSSON, Dr.Sc.(Eng.), A.F.R.Ae.S.

86th ANNUAL REPORT OF COUNCIL 1950-1951

REVIEWS

CORRESPONDENCE

LONDON

ROYAL AERONAUTICAL SOCIETY, 4 HAMILTON PLACE, W.1

Fully
Patented

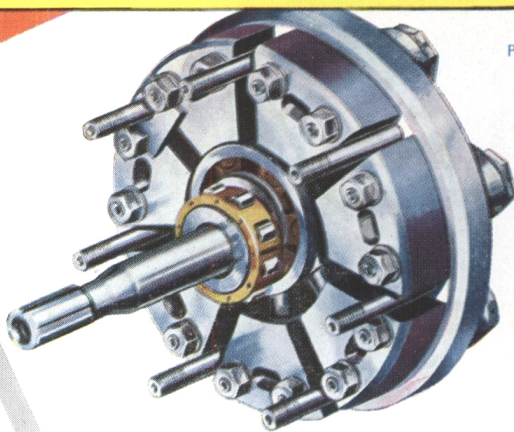

**THE LOCKHEED MARK VII
HYDRAULIC PUMP**
Outstanding in performance and
reputation. For pressures up to 3,000
p.s.i. at 4,000 r.p.m.
Weight only 7 lb. 6 oz.

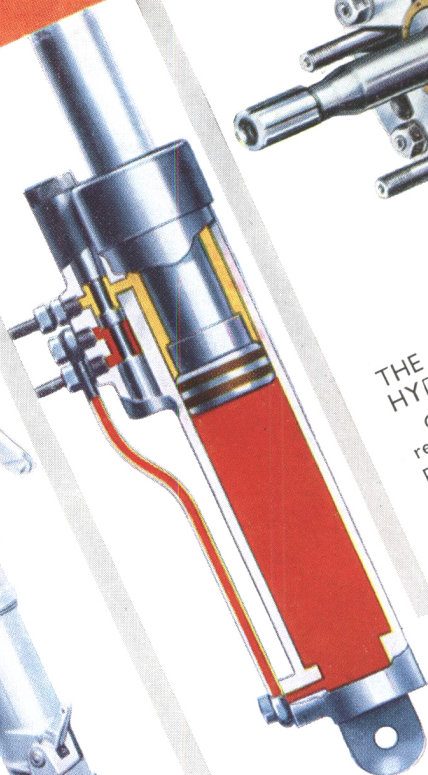

THE SERVODYNE
The perfect system of power
assistance for flying controls.
Basic principle minimises 'dead
points.'

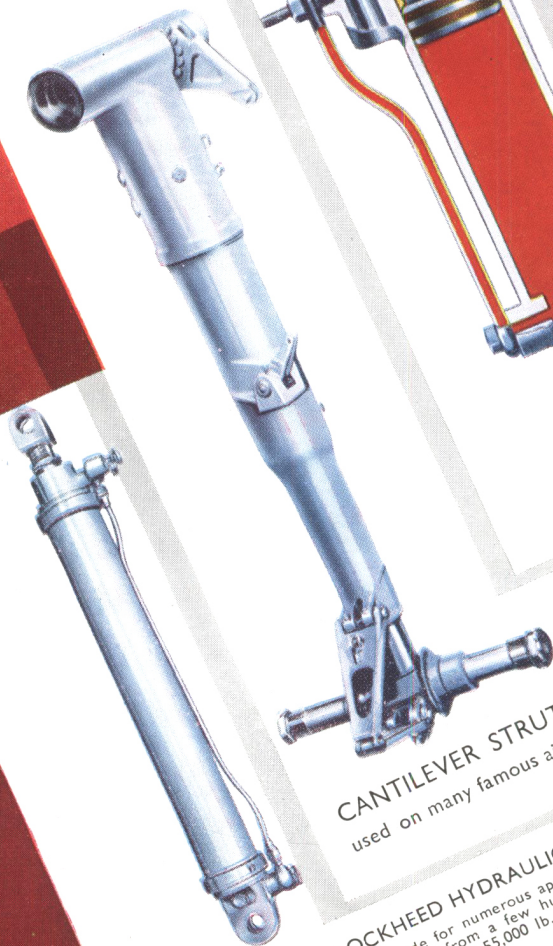

CANTILEVER STRUTS
used on many famous aircraft.

LOCKHEED HYDRAULIC JACKS
As made for numerous applications
ranging from a few hundred lb.
thrust to 55,000 lb.



AUTOMOTIVE PRODUCTS COMPANY LTD., LEAMINGTON SPA

Getting Cracking . . .

WE all know about oil. We've seen it on the movies. There's this fellow whatsisname—a Gary Cooper type—weary and lean-jawed, and there's a blonde in a check shirt in the offing. And one fine technicoloured day, after years and years of failure, privation and squalor . . . whoops! Up she comes. There he is, our hero—his rows of white teeth gleaming in blackened, oil-soaked features—running for a marriage licence. That's oil.

Well, isn't it? They pump the stuff from Nature's underground reservoirs, label it petrol, gasoline or juice and bury it again under garages and airports. They do the same with gold, don't they? Unearth it in South Africa and bury it at great expense on the other side of the world. Right?

Not quite; we're forgetting something. We're forgetting that crude oil is crude. We're forgetting chewing gum, candles, insecticides, explosives, inks, paints, synthetic rubber, diesel fuels, asphalt, lubricating oils, salves, creams, ointments, tractor fuels, jet fuels . . . motor spirit, AVIATION FUELS . . . and a thousand other things. No, the oil industry isn't merely a super transport organisation charged with the task of moving oil



from well to consumer by means of fine fleets of tankers, tank cars and pipe-lines: it's a dozen industries in one, and its chief job is to convert crude oils into fuels of maximum efficiency for every type of engine.

Think of an octane number . . . double it . . . double it again. That's roughly what the industry's been up to these last few years. It has recently produced aviation fuels so high in anti-knock value that they ran right off the octane* scale and met up with a new yardstick, PN or Performance Number. And the work of tailoring fuels to fit engines and

* The octane or grade number of a fuel is simply the measure of its ability to resist detonation. The more compression a fuel can withstand without knocking when fired in the cylinder of an engine the higher its octane rating.

engines to fit fuels goes on, and on. The engineers, scientists, technologists and physicists of the oil industry sit in their laboratories and think of a performance number . . . double it. . . .

No, it's not just a matter of emptying wells and filling pumps.

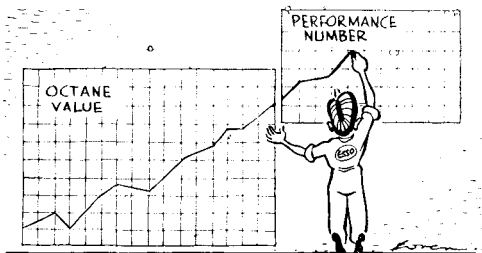

What is the oil industry doing in Britain? Answer—the biggest job in its history. What are ESSO doing? Answer—their biggest job ever. In this country we're now using about seventeen million tons of oil products a year. Nearly all of this oil is imported—from the Caribbean and increasingly from the Middle East—and half of it was refined overseas. But soon, two years from now, when the industry's £125,000,000 building programme has been largely completed, the country will be independent of refineries abroad.

Production at British refineries and cracking plants will be something like twenty million tons of petroleum products a year. *It was three and a half million in 1948.*

One single unit of the industry will be responsible for more than a quarter of this vast output—Esso's giant refinery, now half built, at Fawley, near Southampton. This plant, built and financed entirely by private enterprise, is now expected to go "on stream" towards the end of 1951 with an ultimate annual output of over 6,000,000 tons of petroleum products.

All this in our tight little island where, as somebody said, there isn't room to swing a catalytic cracking unit.

It pays to say



FOR ALL PETROLEUM PRODUCTS

ANGLO-AMERICAN OIL COMPANY LIMITED, 36 QUEEN ANNE'S GATE, LONDON



***to meet
specific needs . . .***

The "Bristol" aircraft and engine production programme provides for world-wide air-line needs . . . long-range trans-oceanic air-liners . . . medium-range aircraft primarily for the Empire routes . . . also freight-planes and helicopters . . . "Bristol" sleeve-valve engines and turbines continue to be among the most widely used power-units in the aircraft industry.

932A

THE *Bristol* AEROPLANE COMPANY LIMITED · ENGLAND

Physical properties of 'PERSPEX' acrylic sheet

—variation with temperature

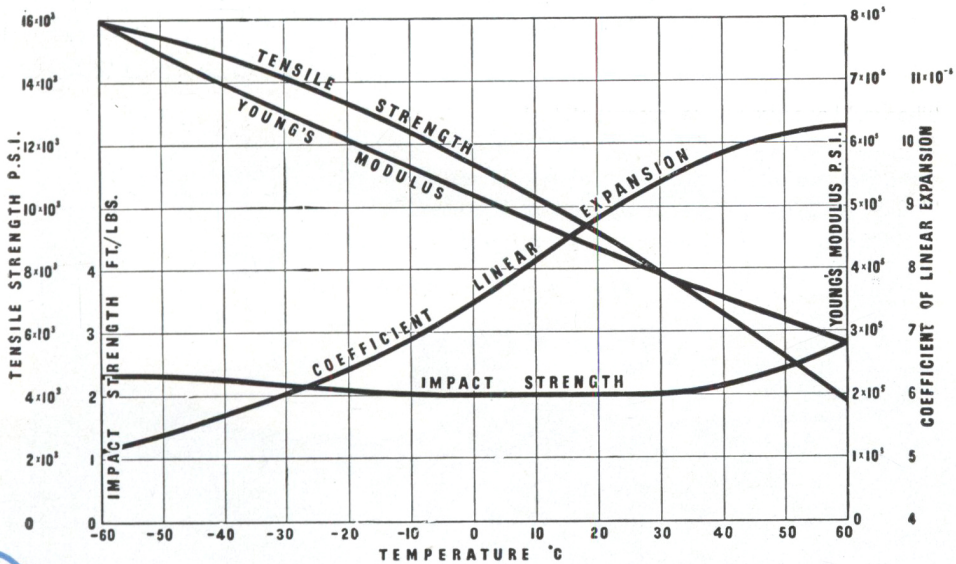

'PERSPEX' is the registered trade mark of the acrylic sheet manufactured by I.C.I.

For Literature and further information apply to

PLASTICS DIVISION · IMPERIAL CHEMICAL INDUSTRIES LTD

Welwyn Garden City · Herts.



PULLIN

*Turn
and Slip
Indicators*

ARE FITTED TO

DE HAVILLAND COMET · SUPERMARINE ATTACKER

APOLLO · BLACKBURN YA 5 · ENGLISH ELECTRIC CANBERRA

GLOUCESTER METEOR 8 AND NF 11

DE HAVILLAND VENOM AND MANY OTHERS

R . B . P U L L I N & C O L T D

Suppliers of Instruments for Service and Civil Aircraft

PHOENIX WORKS, GREAT WEST ROAD, BRENTFORD, MIDDLESEX

Telephone : EALing 0011/3 & 3661/3

Telegrams : Pullinc, Wesphone, London.

18454

The 14.28 plane for Amsterdam...

...owes much to

DURALUMIN

REGD TRADE MARK

The world of aeronautics owes much to James Booth & Co. Ltd., manufacturers of "Duralumin", who pioneered the use of strong light aluminium alloys in this country. Today, such fine aircraft as the Vickers Viking make use of "Duralumin"—a tribute to its continued excellence.



JAMES BOOTH & CO. LTD · ARGYLE STREET WORKS · BIRMINGHAM 7

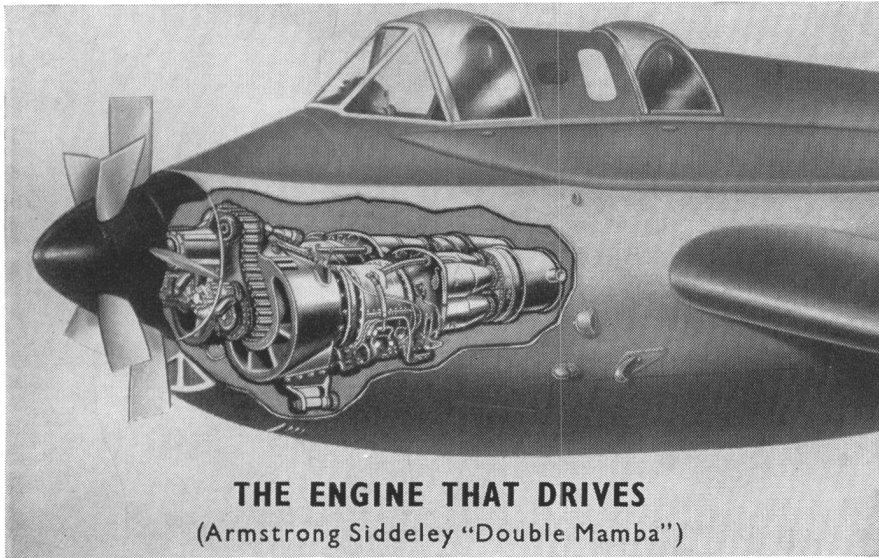

THE ENGINE THAT DRIVES
(Armstrong Siddeley "Double Mamba")



THE AIRCRAFT THAT STRIKES
Twin Engine Performance—Single Engine Installation



**TWIN-ENGINE · ANTI-SUBMARINE
CARRIER-OPERATED**

FAIREY 17

THE FAIREY AVIATION COMPANY LTD., HAYES, MIDDLESEX

Filling in the *Outlines*...

... and placing in true perspective the significance of current aeronautical developments, **THE AEROPLANE** provides a weekly source of reliable information and sound comment on World Aviation.



ONE SHILLING
WEEKLY
ANNUAL RATE
£3 · 3 · 0
POST FREE

TEMPLE PRESS LIMITED



BOWLING GREEN LANE, LONDON, E.C.1, TERMINUS 3636

THE MOTOR	•	THE COMMERCIAL MOTOR	•	CYCLING	•	PLASTICS	•	THE OVERSEAS ENGINEER
THE AEROPLANE	•	THE MOTOR SHIP	•	THE LIGHT CAR	•		•	THE MOTOR BOAT AND YACHTING
LIGHT METALS	•	FARM MECHANIZATION	•	MOTOR CYCLING	•		•	THE OIL ENGINE AND GAS TURBINE



PROVING TEST

This vertical drop test machine is 35 ft. high and is stressed for a vertical reaction of 150 tons with side loads of 0.3 and drag loads of 0.4 vertical reaction. This is just one of the features of the testing carried out by Electro-Hydraulics Limited enabling undercarriages to be built combining the lowest weight with the utmost strength for the longest life.

**ELECTRO-
HYDRAULICS**
LIMITED

WARRINGTON



G.E.C. Electrical Equipment for Passenger Service in **AIRCRAFT** includes:-

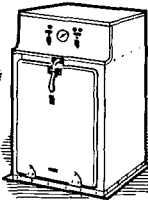

**COOKERS
MOTORS
GENERATORS
RADIO**

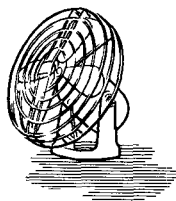

**EQUIPMENT
REFRIGERATORS
HEATING and
VENTILATION**

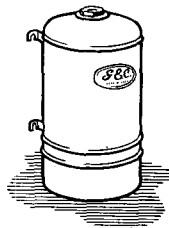

**LIGHTING FITTINGS
OSRAM LAMPS
PIRELLI-GENERAL
CABLES**

Consult the

G.E.C.

*Aeronautical
Advisory
Service*

*Complete airport lighting
equipment and lighting
equipment for offices,
restaurants, hangars, etc.*

THE GENERAL ELECTRIC CO. LTD., MAGNET HOUSE, KINGSWAY, LONDON, W.C.2



*The PRESTWICK PIONEER powered
by the Alvis Leonides engine*



LEONIDES

ALVIS LIMITED, COVENTRY, ENGLAND

Leaders of an *Industry*

Responsible for a third of the RAF's wartime aircraft and more than ever leaders to-day — with a personnel of 38,000 and unmatched facilities for design, research and production — the Hawker Siddeley Group is the largest organisation of its kind in the world.



SIR W. G. ARMSTRONG WHITWORTH AIRCRAFT LTD
ARMSTRONG SIDDELEY MOTORS LTD.
GLOSTER AIRCRAFT CO. LTD. · A. W. HAWKSLEY LTD
HAWKER AIRCRAFT LTD. · HIGH DUTY ALLOYS LTD.
A. V. ROE & CO. LTD. · A. V. ROE CANADA LTD.
AIR SERVICE TRAINING LTD.

the Hawker Siddeley **Group**
LTD

18 St. James's Square, London, S.W.1. Tei: Whitehall 2064

WESTON

AIRCRAFT INSTRUMENTS

No. 1. Temperature Measuring

The comprehensive range of Weston temperature measuring instruments covers the requirements of existing production aircraft, as well as types now under development. In addition to thermometry for the indication of cylinder, air, oil and radiator temperatures, Weston equipment for aircraft includes instruments for supply, navigational aid instruments, selector switches, etc.

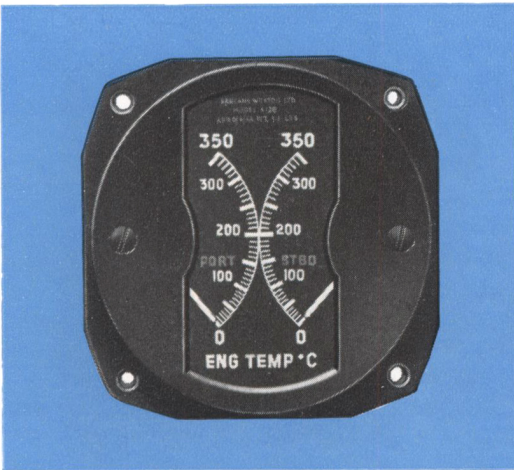

Model S. 128. Dual Engine Temperature Indicator, comprising two Millivoltmeters of 100° scale housed in large-size S.A.E. case. For use in conjunction with copper/constantan, iron/constantan, or chrome/alumel thermocouples.

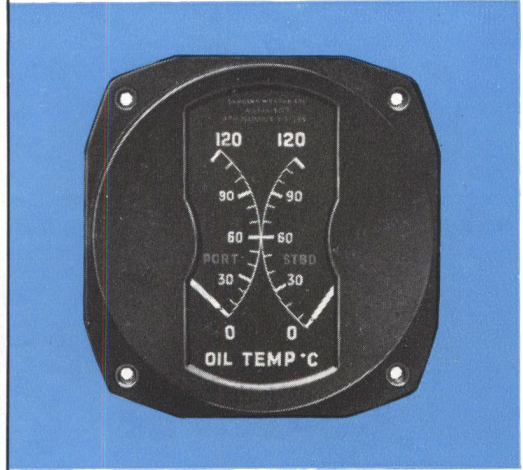

Model S. 127. Dual Radiometer Indicator, comprising two 100° radiometer movements housed in large-size S.A.E. case. For use in conjunction with thermometer bulbs, electrical oil pressure transmitters, electrical position indicators or any combination of two of these to indicate a variety of temperatures, pressures or positions

SANGAMO WESTON LIMITED • Enfield • Middlesex

Tel.: Enfield 3434 (6 lines) and 1242 (4 lines).

Grams: Sanwest, Enfield

Scottish Factory: Port Glasgow • Renfrewshire • Scotland

Branches:

Glasgow, Manchester, Newcastle-on-Tyne, Leeds, Wolverhampton, Bristol, Southampton, Brighton, Liverpool, Nottingham.



He thinks the World of **Q-E-A**

TO-DAY'S seasoned traveller knows it's the combination of experience and organisation that makes Q.E.A. service the world's best in the air transport field to-day.

He knows Q.E.A. has come a long way in 30 years—from the time the pilot adjusted the passenger's goggles and heavy leather coat to the time when the Steward or Air Hostess provides a service that leaves nothing to be desired.

Here's what Q.E.A. passengers say—

Mr.....London/Sydney.

"During the period since the cessation of hostilities I have travelled by air to South America, North America, Canada, Africa and parts of Europe, and without reserve this has been the most satisfactory passage."

Mrs.....Sydney/Singapore.

"The many attentions of the excellent Steward and Stewardess are so much appreciated."

Mr.....Karachi/London.

"The Constellation is the most comfortable of the many planes I have been in."

(Original letters on file)

Fly by Q.E.A. Kangaroo Service (in association with B.O.A.C.) from London—via Rome, Cairo, Karachi, Calcutta, Singapore and Djakarta—to Sydney. Alternative route via Bombay and Colombo. Sydney to New Zealand (By TEAL). Sydney to New Guinea, and Pacific Islands. Sydney to Hong Kong. Sydney to Tokyo via Manila.



Qantas Empire Airways

in association with British Overseas Airways Corporation

A USTRALIA'S INTERNATIONAL AIRLINE **KB**



ACCLES & POLLOCK

**KNOW HOW TO MAKE
THE TUBES THE AIRCRAFT
INDUSTRY NEEDS**

TOP FITTING

*by courtesy of
Dowty Equipment Ltd.*

Precisely!

ACCLES & POLLOCK LTD · OLDBURY · BIRMINGHAM

MAKERS AND MANIPULATORS OF SEAMLESS TUBES, IN STAINLESS AND OTHER STEELS A  COMPANY
ESTD 1873

**THE AERONAUTICAL
QUARTERLY**

Volume II FEBRUARY 1951 Part IV

CONTENTS

Supersonic Flow Investigations with a "Hydraulic Analogy" Water Channel *Joseph Black and O. P. Mediratta*

Contracting Ducts of Finite Length *L. G. Whitehead, L. Y. Wu and M. H. L. Walters*

The Properties of Crossed Flexure Pivots and the Influence of the Point at which the Strips Cross *W. H. Wittrick*

An Analysis of the Lift on Straight, Yawed and Swept-back Wings *J. Lockwood-Taylor*

LONDON
ROYAL AERONAUTICAL SOCIETY
4 HAMILTON PLACE W1

10/-

**THE AERONAUTICAL
QUARTERLY**

**VOLUME III
PART I
MAY 1951**

LONDON
ROYAL AERONAUTICAL SOCIETY
4 HAMILTON PLACE W1

10/-



**Electric Equipment
for Aircraft**

With unrivalled manufacturing resources, backed by continual research and development and fifty-three years' experience, BTH enjoys an enviable reputation for the quality of its products. Reliability is of prime importance on land, but is vital in the air, hence the success of BTH aircraft magnetos, and electrical equipment including :

Motor-generating sets with electronic regulators • Gas-operated turbo-starters • Actuators • A.C. and D.C. Motors • Generators • Mazda lamps, etc.

BRITISH THOMSON-HOUSTON

THE BRITISH THOMSON-HOUSTON CO., LTD., COVENTRY, ENGLAND

A4039

LODGE

AVIATION PLUGS

*serve leading
airlines of the world*

B.E.A., B.O.A.C., Aer Lingus, Aerolineas Argentinas, Air India, "Alitalia", Australian National Airways, Braathen's South American Airways, British West Indian Airways, Central African Airways, Danish Airlines, Malayan Airways, New Zealand National Airways, Norwegian Airlines, Pakistan Aviation, Sabena, South African Airways, Swedish Air Lines, Tasman Empire Airways, Trans Australia Airlines, Trans-Canada Air Lines.

THESE FAMOUS ENGINE MAKERS FIT LODGE:

Alvis, Armstrong-Siddeley, Bristol, De Havilland, Rolls-Royce.

**THE WORLD'S LARGEST CIVIL AIRLINER
FITS LODGE:**

The Bristol "Brabazon" is
fitted with 288 Lodge Plugs.

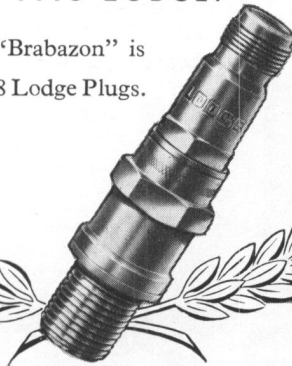

LODGE SPARKING PLUGS—THE EXPERTS' CHOICE

British made throughout by LODGE PLUGS LTD., RUGBY



The Vickers Supermarine 535
—a “swept-back” wing
jet fighter with a
performance to match
the latest needs
of Britain’s defence.

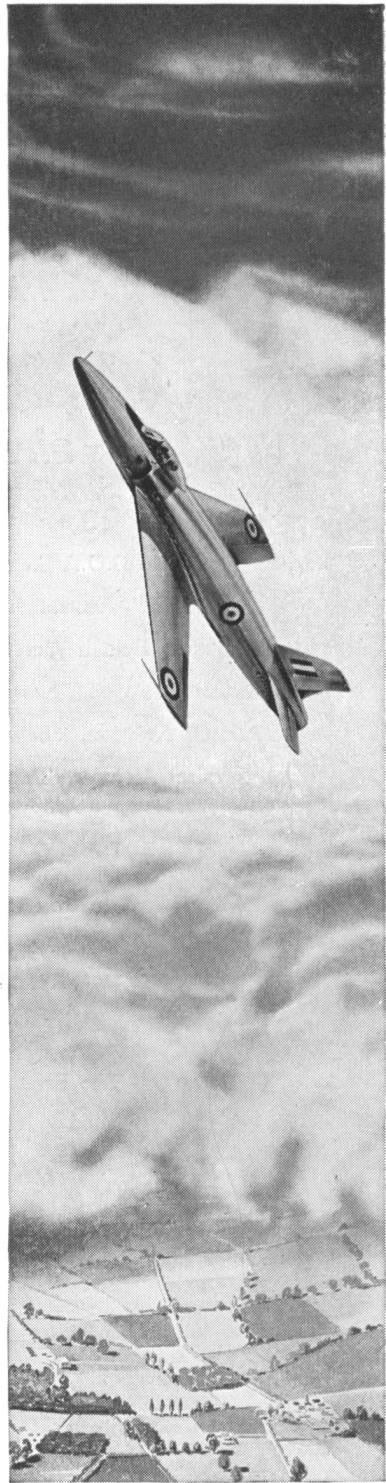

The Vickers Viscount,
world’s first turboprop airliner,
provides smoother, quieter
and safer air travel
with a standard of comfort
never before experienced.



VICKERS-ARMSTRONGS
LIMITED

AT III

A I R C R A F T D I V I S I O N • W E Y B R I D G E • S U K R E T

For very particular people . . .



THE **Monarch**



London-New York Direct — Overnight !

Five flights weekly — Daily flights from 1st May

It's the last word in luxury air travel !

Relax in the double-decked spaciousness of a pressurized Stratocruiser Speedbird . . . meet congenial companions in the lower-deck lounge with its well-stocked bar. Three stewards and a stewardess constantly study to please you.

Enjoy cocktails, a seven-course dinner with wine or champagne, then liqueurs . . . all served with the compliments of B.O.A.C. Finally, you may retire to the privacy of a comfortable full-size berth (only £8. 19. 0 extra). Breakfast in bed, if you wish !

Complimentary "Speedbird Overnight Bag" for every passenger . . . an "Elizabeth Arden Beauty Kit" for every lady.

Yet, you pay no surcharge to travel by this luxurious new overnight service to New York — not a penny extra !



Consult your Travel Agent or B.O.A.C., Airways Terminal, Victoria, S.W.1 (VICtoria 2323) or Regent St., W.1 (MAYfair 6611).

B.O.A.C. TAKES GOOD CARE OF YOU

FLY BRITISH BY **B·O·A·C**

BRITISH OVERSEAS AIRWAYS CORPORATION



D. NAPIER & SON LIMITED · LONDON W. 3

XX

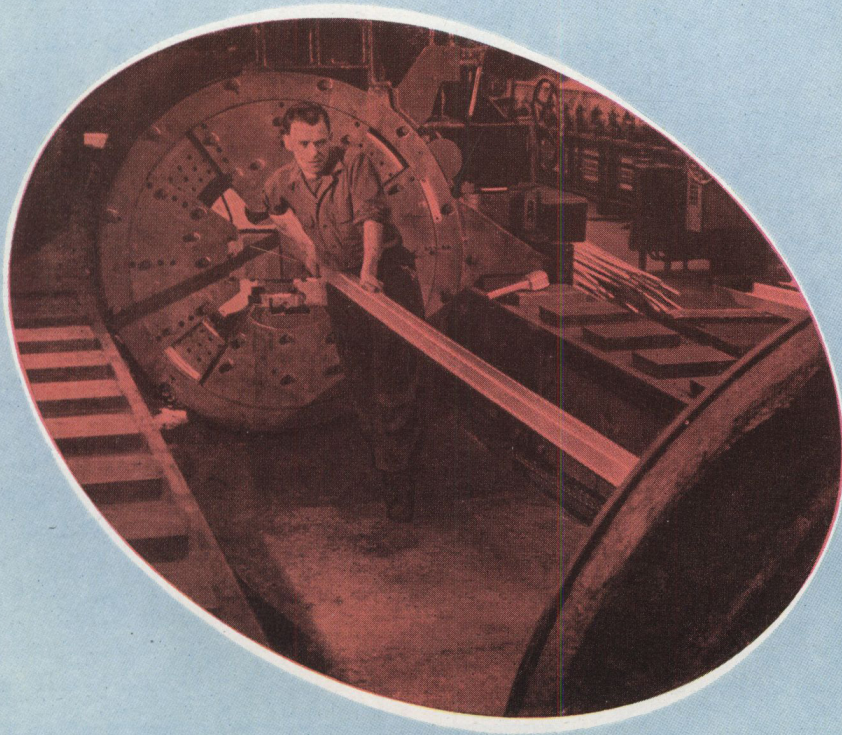

Extrusions in 'Hiduminium'

Because of its easy flow and the fact that it can be extruded with a minimum amount of wear on dies and tools 'Hiduminium' sections can be produced in an almost endless variety of shapes. Following the extrusion process, sections are straightened and checked for trueness in the 250 ton straightening machine shown above. 'Hiduminium' Extrusions enable many industries to



make light work of it with

**HIGH
DUTY
ALLOYS**

HIGH DUTY ALLOYS LTD., Slough, Bucks. Telephone: Slough 21201. Ingot, Billets, Forgings, Castings & Extrusions in 'Hiduminium'* and Magnuminium** Aluminium & Magnesium Alloys.

*REGISTERED TRADE MARKS

**THE
HIGHEST
TRIBUTE
OF ALL**

*Only the best is
good enough for
the Royal Air Force*

that is why

SKYHI HYDRAULIC AIRCRAFT JACKS

are standard equipment in the R.A.F. for the maintenance of their aircraft.

ALSO SKYHI EQUIPPED are the Brabazon, the Comet, and the Blackburn GAL. 60.



Hydraulic
AIRCRAFT JACKS

are used by all the leading aircraft manufacturers throughout the world.

SKYHI LIMITED, SKYHI WORKS, WORTON ROAD, ISLEWORTH, MIDDLESEX