

UPDATE ON THE PERFORMANCE OF THE SUERC *IN SITU* COSMOGENIC ¹⁴C EXTRACTION LINE

R H Fülöp^{1,2,3} • P Naysmith² • G T Cook² • D Fabel¹ • S Xu² • P Bishop¹

ABSTRACT. In this paper, we describe improvements to the *in situ* cosmogenic radiocarbon extraction system at SUERC made since 2004, highlighting the factors that potentially control the reduction of analytical variability. We also present new results on system blanks and of measurements of *in situ* ¹⁴C in shielded quartz and a surface quartz sample used at the University of Arizona as an *in situ* ¹⁴C standard (PP-4). The SUERC *in situ* ¹⁴C extraction system was built in 2001 and is based on a combustion technique following the design of the extraction system at the University of Arizona. Our preliminary results suggest that the continuous running of the extraction system and the monitoring of gas collecting time and of the temperature of the cryogenic traps used in the gas cleaning steps are key to maintaining low and stable system blanks. Our latest average system blank is $2.02 \pm 0.23 \times 10^5$ ¹⁴C atoms. This is consistent with those recently published by the University of Arizona and ETH *in situ* ¹⁴C labs. Measurements of *in situ* ¹⁴C concentrations in sample PP-4 yield an average of $3.82 \pm 0.23 \times 10^5$ atoms g⁻¹ quartz, again consistent with published values.

INTRODUCTION

Although not yet routinely analyzed, *in situ* cosmogenic radiocarbon (*in situ* ¹⁴C) has the potential to be a very versatile tool to geoscientists. First, it has a relatively short half-life (5730 yr), meaning that when compared to the other cosmogenic nuclides, namely, ³He, ¹⁰Be, ²¹Ne, ²⁶Al, and ³⁶Cl, *in situ* ¹⁴C is substantially more sensitive, and so, is particularly useful for dating recent (Holocene) events and identifying rapid changes in erosion rates. Furthermore, *in situ* ¹⁴C is produced in quartz, a mineral that is both highly resistant to weathering and common in nature, and so it can be used alongside the routinely measured longer-lived cosmogenic ¹⁰Be to resolve complex exposure histories involving burial and/or erosion occurring over the past 25 kyr.

The *in situ* ¹⁴C extraction system of Scottish Universities Environmental Research Centre (SUERC) was built in 2001 and is based on the design of the extraction system at the University of Arizona (Lifton et al. 2001; Pigati 2004). The SUERC *in situ* ¹⁴C system works by heating purified quartz to 1100 °C in a resistance furnace in the presence of lithium metaborate (LiBO₂) and ultra-high purity oxygen. Any released carbon is oxidized and the resulting CO₂ is cryogenically cleaned, diluted with ¹⁴C-free CO₂, and converted to graphite. The latter is pressed into targets and measured at the SUERC AMS.

Preliminary results on system blanks and CO₂ recovery obtained using the SUERC extraction system have been presented by Naysmith et al. (2004) and Naysmith (2007). In this paper, we describe improvements to the extraction system since 2004, highlighting the factors that potentially control the reduction of analytical variability. We also present new results on system blanks and of measurements of *in situ* ¹⁴C in shielded quartz and a surface quartz sample previously analyzed at the University of Arizona (PP-4).

METHODS

Ultrapure quartz was prepared at the University of Glasgow following a modified version of the protocol of Kohl and Nishiizumi (1992). AMS measurements were carried out using the 5MV NEC

¹Geographical and Earth Sciences, University of Glasgow, Glasgow G12 8QQ, Scotland

²Scottish Universities Environmental Research Centre (SUERC), East Kilbride G75 0QF, Scotland.

³Corresponding author. Email: r.fulop@suerc.gla.ac.uk.

Pelletron at SUERC (Freeman et al. 2004). The measurements are described in detail by Maden et al. (2007).

¹⁴C Extraction and Graphitization Procedure

The procedure used here is largely based on that described by Naysmith et al. (2004) with the following notable exceptions: (1) the quartz tube is cleaned more rigorously and handled with utmost care; (2) the gas is collected for an additional 1 hr after the 1100 °C heating step; and (3) the temperature in all cryogenic traps is constantly monitored using a thermocouple and controlled by slowly adding liquid N₂.

The extraction procedure is started by cleaning a 65-cm-long and 41-mm-diameter quartz tube that will hold the alumina (Al₂O₃) sample boat (135 mm × 13 mm width × 17 mm depth). The quartz tube is carefully placed on a surveying tripod fitted with a quartz rod and heated up to >800 °C using a glass blower's torch for several minutes to burn off any surface contamination. After cleaning, the quartz tube is inserted into the mullite (an aluminosilicate ceramic) tube that runs through the furnace (Figure 1). In order to avoid any post-cleaning contamination, the quartz tube is carefully handled using gloves and stainless steel tongs. The Al₂O₃ boat that will hold the sample is cleaned using a jet of compressed air and placed in a separate small furnace for 8 hr at 850 °C in air. The boat is cooled and LiBO₂ is added to the Al₂O₃ boat, which is carefully placed inside the quartz tube that was cleaned earlier. The furnace and recirculating section of the extraction line are pumped until pressure drops to 10⁻⁵ mbar, then the LiBO₂ is degassed in an ultra-high-purity oxygen (UHP O₂) atmosphere at a pressure of 30–40 mbar for 2 hr at 1100 °C. The furnace is allowed to cool overnight to 120 °C before it is opened and the quartz sleeve and boat removed. Five grams of quartz, which have been washed the previous day in 50% HNO₃ solution to remove any surface contamination, are placed in the Al₂O₃ boat, which is then returned to the quartz sleeve and placed back in the furnace; when performing system blank measurements, everything is done in the same way except no quartz is added. Next, the sample undergoes a 2-stage heating process. The furnace and recirculating section are pumped until pressure drops to 10⁻⁵ mbar before heating the furnace to 500 °C in a recirculating UHP O₂ atmosphere of 30–40 mbar for 1 hr. Any CO₂ that is produced at this heating step is considered to be from atmospheric contamination and discarded (cf. Lifton et al. 2001). After the

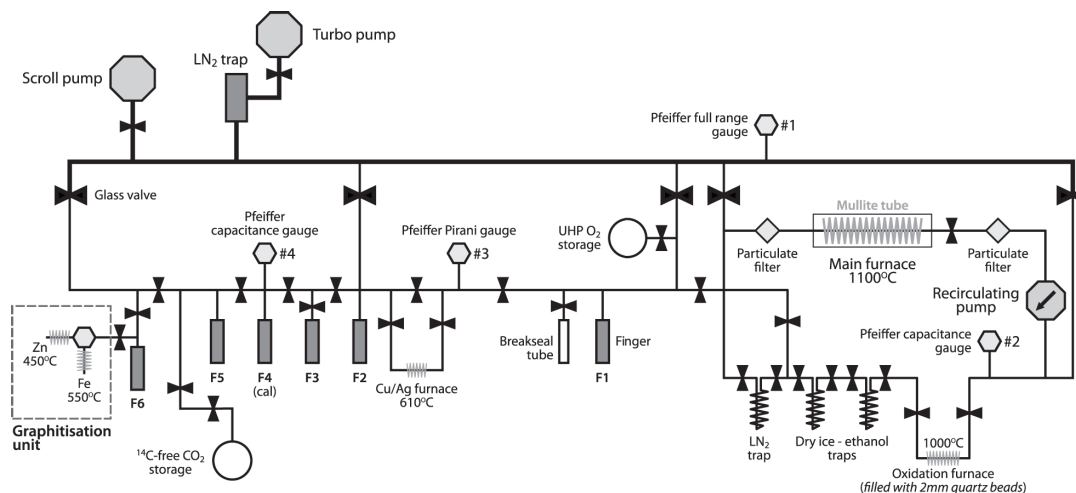

Figure 1 The SUERC vacuum system for extraction, purification, and graphitization of *in situ*-produced ¹⁴C

line is pumped down once again to 10^{-5} mbar, the furnace is reheated to 1100 °C for 3 hr in a UHP O_2 atmosphere of 30–40 mbar and the resulting CO_2 —which is considered to be from *in situ* production (Lifton et al. 2001)—is cryogenically trapped using liquid N_2 for an additional 1 hr. Contaminant gases (including SO_x and NO_x species) are removed by passing the resulting CO_2 through an n-pentane/liquid N_2 trap at -130 °C and reheating to 610 °C in a quartz combustion tube containing Cu/Ag filter for 20 min. Next, the gas is passed through an iso-pentane/liquid N_2 trap at -150 °C. The cleaned CO_2 is measured using a highly sensitive capacitance manometer and diluted to approximately 1 mL using ^{14}C -free CO_2 derived from an “infinite age” Icelandic doublespar. The CO_2 is then reduced to graphite using Fe and Zn as described by Slota et al. (1987). The graphite is removed from the vacuum extraction line and pressed into an AMS target.

RESULTS AND DISCUSSION

Results are summarized in Tables 1 and 2 and Figures 2 and 3. Prior to November 2008, all ^{14}C measurements at SUERC were done without monitoring and adjusting the temperature of the cryogenic traps—i.e. the temperature of the n-pentane/liquid N_2 and iso-pentane/liquid N_2 traps was never measured to ensure that they were at the appropriate temperatures of -130 °C and -150 °C, respectively. Since November 2008, this has changed and now the temperature of the cryogenic traps is monitored using a thermocouple and the slushes are kept at -130 °C and -150 °C, respectively, by slowly adding liquid LN_2 . In Figures 2 and 3, the switch to temperature-controlled cryogenic cleaning is indicated by vertical dashed lines. All results were calculated according to the procedures set out by Lifton (1997) and Lifton et al. (2001). Graphitization blanks were corrected for as set out by Donahue et al. (1990).

System Blanks and Shielded Quartz

In order to determine the system blanks, we followed the complete procedure described above without placing any quartz in the alumina boat. The shielded quartz was separated from a granite taken from a depth of 1.5 km from Rosemanowes Quarry, SW England (Chen et al. 1996), and so at least theoretically it should be free of any *in situ* ^{14}C .

The system blanks exhibited substantial fluctuations at the beginning of the study, suggesting that the continuous running of the extraction system was slowly cleaning contaminant carbon from the line. These fluctuations in the system blanks were also reduced with longer cleaning of the quartz sleeves and close monitoring of gas collecting time and of the temperature of the cryogenic traps used in the gas cleaning steps (Figure 2). The average of all system blanks that were measured as part of this study is $2.75 \pm 0.77 \times 10^5$ ^{14}C atoms. The average of system blanks that were measured when controlling the temperature of the cryogenic traps is lower, $2.02 \pm 0.23 \times 10^5$ ^{14}C atoms. Both values are comparable with those reported by Miller et al. (2006) and obtained at the University of Arizona using extraction procedures modified from Lifton et al. (2001)—yielding an average system blank of $2.40 \pm 0.12 \times 10^5$ ^{14}C atoms—and from Pigati (2004)—yielding an average system blank of $1.50 \pm 0.10 \times 10^5$ ^{14}C atoms (Figure 2). Our system blanks are also comparable (although slightly lower) with those recently obtained at ETH in Zurich (Hippe et al. 2009).

The shielded quartz results exhibit the same pattern as the system blanks (Figure 2). There is considerable variability in the obtained concentrations, although, similarly to the system blanks, the data suggest that the extraction system is slowly cleaning with use. The 2 data points that were obtained using temperature-controlled cryogenic traps are identical within uncertainty. However, using these 2 data points alone, it is not possible to infer whether controlling the temperature of the traps has any effect on lowering analytical variability, as suggested by the system blanks.

Table 1 Results of the system blank (top) and shielded quartz (bottom) measurements. All uncertainties are at the 1- σ level.

System blanks				
AMS ID	<i>F</i> value	CO ₂ (10 ⁻² mL)	Diluted CO ₂ (mL)	¹⁴ C (10 ⁵ atoms)
G18611	0.0399 ± 0.0004	5.748	0.996	11.51 ± 0.10
G18616	0.0183 ± 0.0003	4.056	1.015	5.39 ± 0.08
G18618	0.0063 ± 0.0002	2.668	0.994	1.83 ± 0.05
G20684	0.0029 ± 0.0002	0.868	1.012	0.84 ± 0.04
G20688	0.0026 ± 0.0002	0.824	0.990	0.74 ± 0.05
G21809	0.0070 ± 0.0003	1.779	1.002	2.04 ± 0.09
G22985	0.0037 ± 0.0004	0.954	1.001	1.08 ± 0.12
G22986	0.0062 ± 0.0005	1.475	1.001	1.79 ± 0.14
G22987	0.0056 ± 0.0004	1.497	1.001	1.62 ± 0.12
G22989	0.0114 ± 0.0005	2.061	0.998	3.28 ± 0.16
G22990	0.0070 ± 0.0004	1.518	1.000	2.03 ± 0.13
G22991	0.0063 ± 0.0005	1.302	1.000	1.82 ± 0.13
G22995	0.0060 ± 0.0005	1.215	1.000	1.74 ± 0.15
G22996	0.0094 ± 0.0006	1.562	1.002	2.74 ± 0.17
			Mean value—all:	2.75 ± 0.77
			Mean value—temperature control:	2.02 ± 0.23
Shielded quartz				
AMS ID	<i>F</i> value	CO ₂ (10 ⁻² mL)	Diluted CO ₂ (mL)	¹⁴ C ^a (10 ⁴ atoms g ⁻¹)
G18615	0.0399 ± 0.0003	3.991	1.006	14.20 ± 0.18
G18619	0.0063 ± 0.0002	0.954	1.001	2.97 ± 0.11
G20677	0.0017 ± 0.0001	0.694	1.009	1.01 ± 0.08
G20678	0.0020 ± 0.0002	0.716	1.006	1.17 ± 0.09
G20679	0.0061 ± 0.0002	1.302	0.995	3.52 ± 0.10
G22965	0.0074 ± 0.0005	2.256	0.999	4.31 ± 0.28
G22966	0.0065 ± 0.0005	9.284	1.002	3.76 ± 0.28
			Mean value—all:	4.42 ± 1.83

^aNot corrected for system blanks.Table 2 Results of the reproducibility measurements (PP-4). All uncertainties are at the 1- σ level.

AMS ID	<i>F</i> value	CO ₂ (10 ⁻² mL)	Diluted CO ₂ (mL)	¹⁴ C (10 ⁵ atoms g ⁻¹)
G20699	0.0717 ± 0.0004	8.633	0.998	3.81 ± 0.29
G20704	0.0647 ± 0.0004	6.551	1.005	3.40 ± 0.29
G20705	0.0589 ± 0.0004	6.182	1.001	3.02 ± 0.29
G21793	0.0753 ± 0.0005	7.592	1.000	4.05 ± 0.30
G21797	0.0724 ± 0.0006	6.941	0.995	3.84 ± 0.30
G21798	0.0718 ± 0.0006	7.072	0.999	3.82 ± 0.30
G22975	0.0828 ± 0.0010	7.896	0.997	4.75 ± 0.10
G22976	0.0665 ± 0.0010	6.573	0.999	3.74 ± 0.09
G22977	0.0722 ± 0.0010	7.245	1.000	3.97 ± 0.09
			Mean value:	3.82 ± 0.23

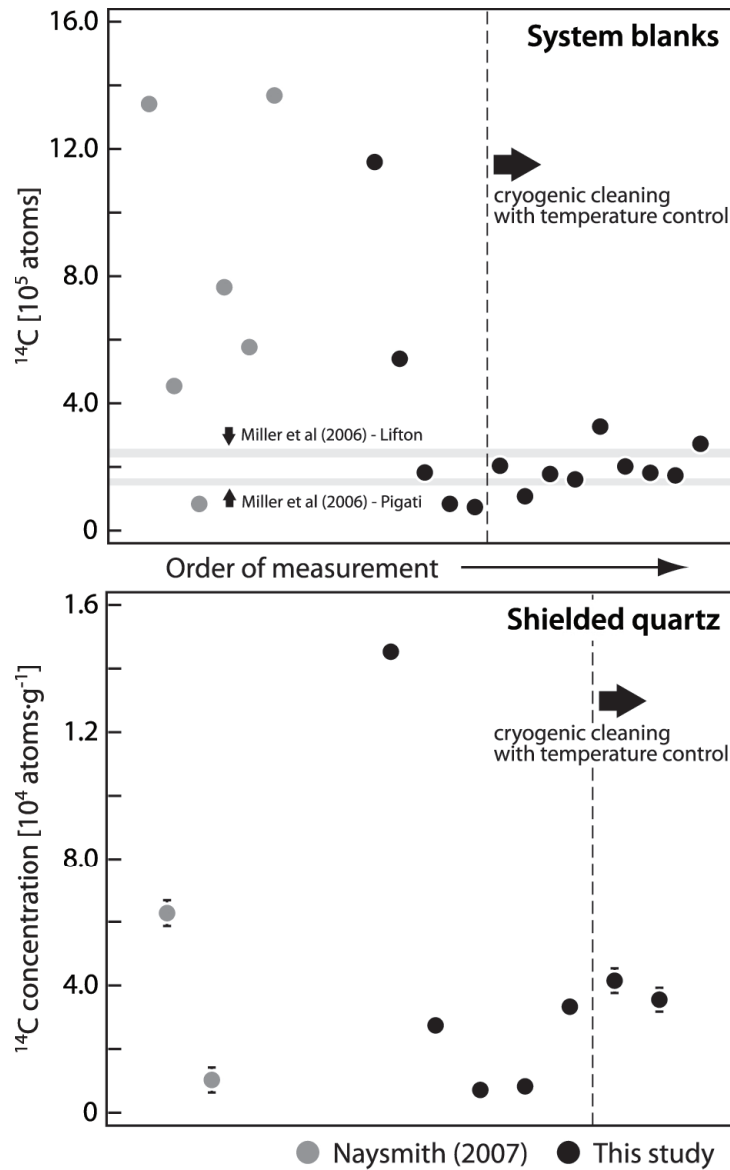

Figure 2 Results of the system blank (top) and shielded quartz (bottom) measurements. Data points plotted to the right of the dashed line were obtained by controlling the temperature of the cryogenic traps using a thermocouple and keeping the slushes at $-130\text{ }^\circ\text{C}$ and $-150\text{ }^\circ\text{C}$, respectively. The 2 gray horizontal bands on the top graph (labeled Miller et al. (2006)–Lifton and Millet et al. (2006)–Pigati, respectively) show the mean system blank values from Miller et al. (2006). The heights of the rectangles are equal to the uncertainties of the 2 mean blank values.

Reproducibility Measurements

To assess the efficiency of the system, we have also measured *in situ* ^{14}C in a Lake Bonneville shore-line surface quartz sample (PP-4), which has been used as an internal standard at the University of

Arizona (Lifton et al. 2001). Figure 3 compares our results with the latest PP-4 results from the University of Arizona *in situ* ^{14}C lab (Miller et al. 2006).

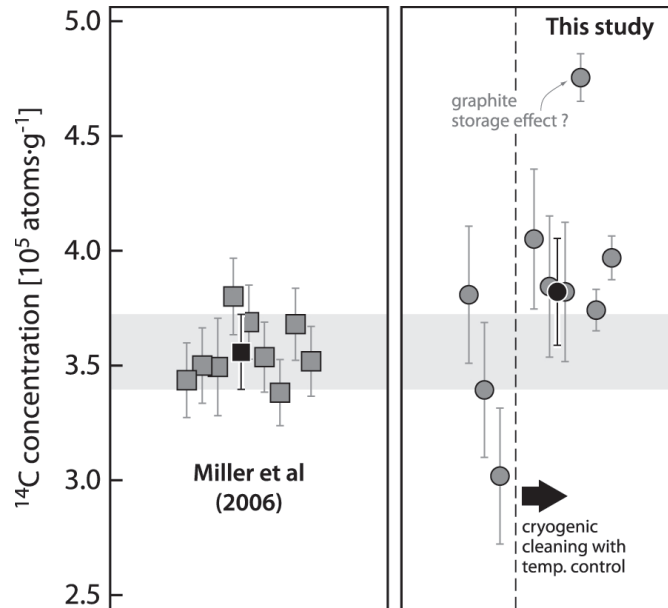

Figure 3 Results of the reproducibility measurements (PP-4). The gray symbols are the individual data points and the black symbols are the mean values obtained for each study. See text and caption of Figure 2 for more details.

Measurements of *in situ* ^{14}C concentrations in sample PP-4 yield an average of $3.82 \pm 0.23 \times 10^5$ atoms g^{-1} quartz. This value is consistent with that obtained by Miller et al (2006), namely $3.56 \pm 0.16 \times 10^5$ atoms g^{-1} . Nonetheless, our measurements show a considerably larger spread than those of Miller et al. (2006). Although we do not yet know what the cause of the variability in our PP-4 results is, we suspect 2 factors. First, some of the PP-4 measurements were carried out prior to monitoring the temperature of the cryogenic traps (Figure 3), and although we do not have an estimate of how much the temperature of the slushes may have fluctuated during these measurements, this fluctuation might have contributed to the observed variability. Second, the graphite obtained from the seventh PP-4 sample was stored for more than 4 months prior to the AMS measurement, and so there is a possibility that this sample has been contaminated. Excluding the seventh PP-4 sample and the ones that were measured prior to controlling the temperature of the cryogenic traps, yields an average that is slightly higher ($3.88 \pm 0.22 \times 10^5$ atoms g^{-1}) but still indistinguishable within uncertainty from that obtained by Miller et al. (2006). Recently, the University of Arizona ^{14}C lab stopped using sample PP-4 for repeatability measurements.

CONCLUSIONS

We have made substantial progress in developing a method for extraction and measurement of *in situ* ^{14}C at SUERC. Our preliminary results suggest that the continuous running of the extraction system and the monitoring of gas collecting time are key to maintaining low and stable system blanks. Our results also suggest that maintaining the temperature of the cryogenic traps constant could also play a role in maintaining system blanks stable. The results of our reproducibility mea-

measurements are satisfactory. Our PP-4 measurements are indistinguishable within uncertainty from the latest PP-4 results published by the University of Arizona ^{14}C lab (Miller et al. 2006), but they are somewhat higher and exhibit more spread. All our future reproducibility measurements will be carried out using the new CRONUS *in situ* ^{14}C standard material.

ACKNOWLEDGMENTS

R H F is funded by a University of Glasgow Postgraduate Scholarship and a British Geological Survey—Universities Funding Initiative (BUFI) award. The authors acknowledge the help of the SUERC radiocarbon and AMS laboratories and William McCormack for his support. Nathaniel Lifton and Jeffrey Pigati are acknowledged for thorough and constructive reviews.

REFERENCES

- Chen Y, Zentilli M, Clark A, Farrar E, Grist A, Willis-Richards J. 1996. Geochronological evidence for post-Variscan cooling and uplift of the Carnmenellis granite, SW England. *Journal of the Geological Society* 153(2):191–5.
- Donahue DJ, Linick TW, Jull AJT. 1990. Isotope-ratio and background corrections for accelerator mass spectrometry radiocarbon measurements. *Radiocarbon* 32(2):135–42.
- Freeman S, Bishop P, Bryant C, Cook GT, Fallick A, Harkness D, Metcalfe S, Scott M, Scott R, Summerfield M. 2004. A new environmental sciences AMS laboratory in Scotland. *Nuclear Instruments and Methods in Physics Research B* 223–224:31–4.
- Hippe K, Kober F, Baur H, Ruff M, Wacker L, Wieler R. 2009. The current performance of the *in situ* ^{14}C extraction line at ETH. *Quaternary Geochronology* 4(6): 493–500.
- Kohl C, Nishiizumi K. 1992. Chemical isolation of quartz for measurement of *in-situ*-produced cosmogenic nuclides. *Geochimica et Cosmochimica Acta* 56(9):3583–7.
- Lifton NA. 1997. A new extraction technique and production rate estimate for *in situ* cosmogenic ^{14}C in quartz [PhD dissertation]. Tucson: University of Arizona.
- Lifton NA, Jull AJT, Quade J. 2001. A new extraction technique and production rate estimate for *in situ* cosmogenic ^{14}C in quartz. *Geochimica et Cosmochimica Acta* 65(12):1953–69.
- Maden C, Anastasi P, Dougans D, Freeman S, Kitchen R, Klody G, Schnabel C, Sundquist M, Vanner K, Xu S. 2007. SUERC AMS ion detection. *Nuclear Instruments and Methods in Physics Research B* 259(1): 131–9.
- Miller GH, Briner JP, Lifton NA, Finkel RC. 2006. Limited ice-sheet erosion and complex *in situ* cosmogenic ^{10}Be , ^{26}Al , and ^{14}C on Baffin Island, Arctic Canada. *Quaternary Geochronology* 1(1):74–85.
- Naysmith P, Cook GT, Phillips W, Lifton NA, Anderson R. 2004. Preliminary results for the extraction and measurement of cosmogenic *in situ* ^{14}C from quartz. *Radiocarbon* 46(1):201–6.
- Naysmith P. 2007. Extraction and measurement of cosmogenic *in situ* ^{14}C from quartz. Glasgow: University of Glasgow. 94 p.
- Pigati JS. 2004. Experimental developments and application of carbon-14 and *in situ* cosmogenic nuclide dating techniques [PhD dissertation]. Tucson: University of Arizona.
- Slota Jr PJ, Jull AJT, Linick TW, Toolin LJ. 1987. Preparation of small samples for ^{14}C accelerator targets by catalytic reduction of CO. *Radiocarbon* 29(2):303–6.