

2 RFID background

Giulia Orecchini and Luca Roselli

2.1 RFID system architecture

RFID (Radio Frequency IDentification) indicates the capability of identifying by means of radio frequency transmissions. The identification involves assigning a unique identity to an object that is distinguishable in an unambiguous way.

In this original form RFIDs have the same functionality as a barcode. Regarding its evolution, the main purpose of this technology, beyond barcodes, is to obtain identified information about objects, animals, or persons by means of small apparatuses working at radio frequency.

The intake of information is achieved by means of searching operations, identification, selection, spatial localization, and tracking.

Identifier and identified communicate using radio frequency signals, hence no physical contact (unlike, for example, use of magnetic stripe cards) is needed.

The predecessor of the RFID system is commonly recognized as being “Identification Friend or Foe (IFF),” developed in England during World War II (1940) [1–3]. The equipment on board allied aircraft had the functionality of answering if questioned, thus identifying allied planes and distinguishing them from enemy aircraft.

The technology has then evolved differently into systems for following the route of railway wagons, for the automation of processes in the automotive industry, for the location of livestock and wildlife, for anti-theft in the retail trade, for keys and electronic documents, and in agriculture and nature reserves, etc. [4–6].

Real-life RFID deployments use a wide variety of physically distributed RFID readers, access gateways, management interfaces, and databases. The goal of radio frequency identification is mainly to allow computers, and ultimately people, to monitor, decide, and consequently take actions.

2.1.1 RFID system general frame

RFID technology consists of three basic elements (Figure 2.1):

- Tag: a radio frequency transponder of small dimensions consisting of an integrated circuit (chip), connected to an antenna. The tag allows for the transmission of data at short range without physical contact.

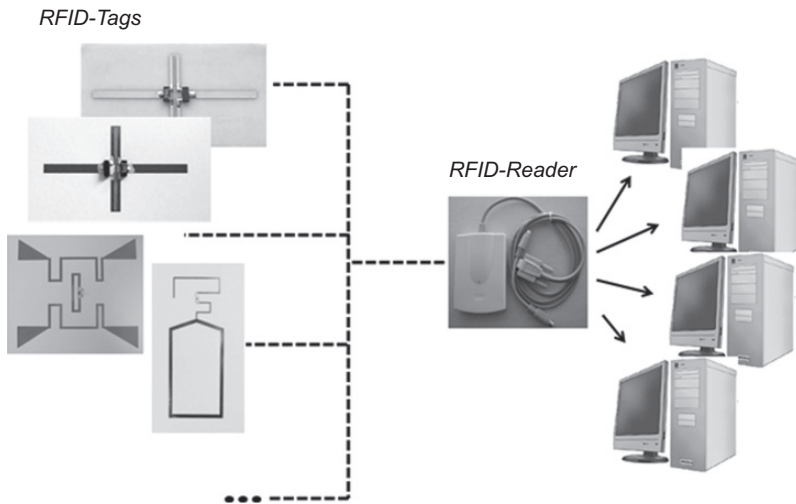

Figure 2.1 RFID system general framework.

- **Reader:** a transceiver controlled by a microprocessor and used to query and receive information in response from one or more tags.
- **Management system:** an information system that, when it exists, is connected to a network with the readers. This system allows, starting from the identification codes coming from the tags, all available information associated with the objects to be obtained and managed.

The tags can be categorized first on the basis of the management of the energy sources. The tag, in fact, can be:

- *Passive:* it gets the energy from the RFID reader signal; it does not have a real transmitter, but it circulates, modulates, and irradiates with its antenna, the signal transmitted by the reader. The distances at which it can operate are, at most, of the order of a few meters.
- *Active:* it is powered by batteries. It incorporates a receiver and a transmitter. It usually has a large memory, often rewritable and may contain sensors or other devices. The coverage range depends on the transmitter and batteries and typically is, at most, of the order of 200 meters. For active tags, in addition to the greater amount of memory and the function of rewriting, technological development has made possible the addition of functions that far exceed pure identification. For example, some additional functionalities are radiolocation (RTLS – real-time location system – position identification of objects hosting the RFID) or the measurement of environmental parameters through sensors (temperature, movement, etc.).
- *Battery-assisted passive (BAP) tag;* it uses an energy source to power only certain components of the tag. BAP tags are also classified as semi-passive or semi-active.

BAP tags are equipped with a battery only to power the microchip or auxiliary apparatuses (sensors for instance) and modulator, but not to supply power to the RF transmitter electronics since, for the transmission, they behave as passive tags just

circulating the signal coming from the reader. The distances at which they can operate are, at most, of the order of a few tens of meters.

To save energy, the tag is normally deactivated. The activation is achieved through a receiver that operates like the one in the passive tag. Passive tags are typically low cost devices and have small dimensions allowing the field of application to be very wide. When the tag passes through the electromagnetic (EM) field generated by a reader it reacts and transmits its information.

Typically a passive tag that receives a signal from a reader uses the same energy of the signal to power its internal circuitry and, therefore, “wake up” its functions. Once the tag has decoded correctly the signal from the reader, it answers reflecting back the signal through its antenna and adding modulation and thus information.

Often each application is tied to particular dimensional characteristics of the tag itself. In fact, the passive tag, consisting only of an antenna (typically printed) and an integrated circuit, generally miniaturized, can have a thickness of a few hundreds of microns. It can therefore be placed on credit cards, labels, stickers, buttons, and other small items made of plastic or paper, thus generating real “talking” objects.

In the past, tags had primarily read-only memory because the step of writing requires the availability of a high amount of energy, which is hard to obtain from the received signal, and because rewritable memories have a relatively high cost.

2.1.2 RFID regulation

The reader is the element that, in RFID systems, is able to capture the information contained in the tag. It is a real transceiver, governed by a system control and often networked with computerized management systems in order to get information from objects and make it available for any use.

As mentioned before, for the success of an application, the tag and the reader have to communicate easily without disturbing other radio services. Therefore, as always happens in applications that require interoperability between parties, the communication standards are essential.

The two main objectives that the standards must meet are:

- interoperability between reader and tag made by different manufacturers;
- no interference with other radio devices’ electrical operations.

The dialogue between reader and tag requires standardization of certain technical parameters:

- Parameters of the two radio frequency communication links, reader-tag and tag-reader (uplink and downlink or forward link and return link);
- Communication protocols used in the same link (definition of procedures and data format for the dialogue);
- Type of signal modulation;
- Coding and packaging of data;
- Transmission of data (bit rate) and bit transmission order;
- Technique of interrogation of the reader (“frequency hopping,” “listen before talk”);

- Anti-collision procedures (ability to detect and classify the greatest possible number of tags at the same time in the reading range).

In addition to those listed above, specifications and standards are required to deal with the following topics:

- The format of the data contained in the tag (the way in which the data are organized or formatted);
- The compliance (the way in which the products meet a standard);
- “Middleware” protocols (specify instructions and how data are processed).

The standardization process is usually managed both at global and regional level, by two classes of organization:

- Those involved in the management of the radio spectrum, which provides essentially the principle of non-interference. To this category belong the ITU (International Telecommunications Union), the CEPT (European Conference of Postal and Telecommunications Administration), and the ERC (European Radio communications Committee);
- Those that deal with communication interfaces, to ensure interoperability between reader and tag with different manufacturers (this category includes ISO and EPC-global).

The main use of RFID tags so far is the identification of objects and more generally in logistics (identification of packaging, pallet, container, and so on down the chain of distribution). The standards for these applications belong to two organizations already mentioned, whose activities are converging:

- EPCglobal, set up and acting as a private association;
- ISO (and bodies connected to it), which is the world body of legislation in almost all fields of technology.

For example, the standards for the radio interface are proposed by both ISO [7] and EPCglobal [8] (the former oriented on all fields, the latter mostly polarized on the specific needs of the supply chain). EPCglobal also covers the application layer, while the standard ISO/IEC 18000 [9] is limited to the radio interface.

The frequencies used for the communication between reader and tag depend on both the nature of the tag and the intended application. They are adjusted (to control emissions of power and to prevent interference) by the international and national organizations. The regulation, however, is divided in geographical regions with different standards from region to region.

The portions of frequency bands used for RFID are shown in Figure 2.2; the most commonly used are:

- LF band (low frequencies) and in particular the sub-band 120 to 145 kHz. It is located in the lower part of the RF spectrum; it is historically the first frequency band used for automatic identification and, even today, continues to have a significant presence in the market.

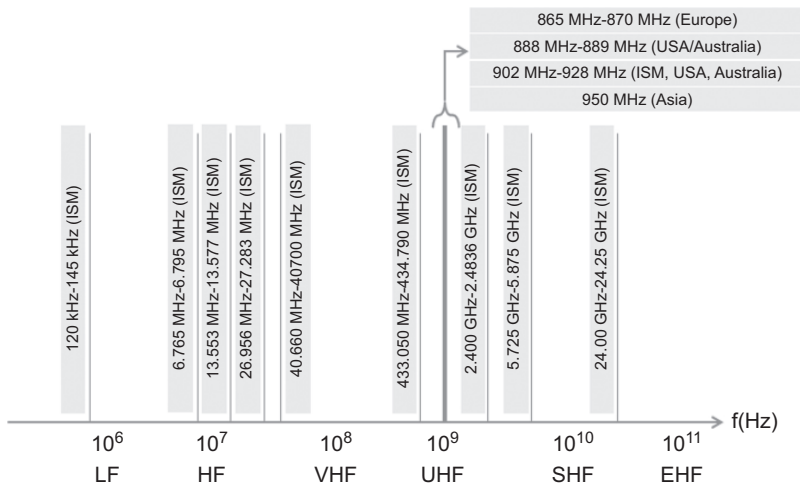

Figure 2.2 Available worldwide frequency bands for RFID.

- HF band (high frequencies) and in particular the sub-band centered on 13.56 MHz. It is considered the “universal” frequency band, usable throughout the world, therefore the most popular band to date.
- UHF band (ultra-high frequencies), and in particular the sub-band 865–870 MHz in Europe, 902–928 MHz in USA, and 950 MHz in Asia. It is the “new band” for RFID for logistics and for the management of individual objects with operating distances significantly higher than the ones allowed by LF and HF bands. Unfortunately, the bandwidth is not uniformly allocated in all countries.
- Microwave frequency band, centered on 2.4 GHz. It has similar characteristics to the previous UHF band, but allows for a further miniaturization of the tag. It is, however, a very crowded band because of other technologies (WiFi, Bluetooth, ZigBee), with which it is necessary to coexist.

There are also other used frequencies such as 433–435 MHz in the UHF low-band and 5.8 GHz SHF (super-high frequencies).

To date (2014), some frequency bands (usually in the LF or HF) are accepted throughout the world. An example is the band of 13.56 MHz, used by many passive tags incorporated mainly in smart cards for access control, identification, and payments, but also into the labels associated with objects, such as luggage checking, laundries, libraries, etc.

The choice of the working frequency influences the operational distance (range) of the system, interference with other radio systems, the transfer speed of data, and the size of the antenna. Systems that use lower frequencies are often based on passive tag structures and are capable of transmitting data at maximum distances of the order of feet (30–120 cm). Higher frequencies are mainly used for active tags resulting in a higher working distance. In these cases the speed of data transfer is generally increased while the size of the antennas is reduced; this allows smaller tags to be built.

The sub-band of LF frequencies, located in the lower part of the RF spectrum (125–145 kHz), is historically the first frequency band used for automatic identification and still remains a significant presence in the market. The coupling between the reader and the tag takes place by induction, with the same physical principle as electrical transformers. In the case of passive tags, the operating distance is approximately equal to the diameter of the reader antenna and varies from 30 cm to a meter; beyond this the field is reduced very quickly, due to the $1/d^3$ effect, while the energy picked up by the tag varies according to $1/d^6$. For this reason, the distance that enables the possible operation of writing into the memory, which has a higher energy consumption, is normally less than the reading range, being typically less than 30 to 50%.

It should be noted that within the LF band there are actually two frequencies that are used most:

- 125.5 kHz mainly in the automotive sector;
- 134.2 kHz in animal traceability.

The frequency of the 125.5 kHz carrier is relatively low and allows a maximum speed of data transmission of the order of thousands of bits per second. The tags at a frequency of 134.2 kHz are used primarily in animal traceability because of the very slight effect that water and fabrics have on transmission.

The sub-band of HF frequencies located at 13.56 MHz is recognized by all regulatory organizations worldwide and this has made it the most popular band up to now. The coupling between the reader and the tag is made by induction, as in LF tags. The shapes and the type of packaging are available in the most disparate forms. The typical configuration provides an antenna formed by a winding made normally of copper, but aluminum, etched from a thin sheet of metal or inkjet printed with conductive ink is also used. The size and the number of turns determine the sensitivity and the operating distance. The costs are lower than those of LF tags but strictly dependent on the support type and size. The HF band is currently the most widely used for the so-called “smart labels” (smart tags) used in logistics and object management, even if, for the latter application, it is anticipated that, in the long term, systems in the UHF band will prevail. In this frequency the contactless smart cards that are the industry’s most developed field of application operate too.

The technological evolution of semiconductors, which led to the realization of very-low-power chips, has allowed RFID tags operating at 860–950 MHz with an operating distance much larger than in LF and HF bands. The coupling between the reader and the tag is made in an electromagnetic way, as in conventional radio systems. A working distance of three meters is now common, and extensions to five meters and more are possible. Thanks to this, the UHF band is certainly destined to be confirmed as the “queen band” in logistics and, above all, in the management of objects. However, some issues, have slowed its introduction:

- Operating frequencies: USA, Europe, and Asia have to account for different frequencies: frequencies already occupied by cell phones and then not usable for RFID applications. Tags are thus often built to enhance the ability to work in a “broadband,”

although performances are usually worsened. For active tags, instead, the transceivers, if necessary, are more easily calibrated to operate on multiple frequencies at the price of an increment of production costs.

- Transmitted power: in USA and Europe there are different limits for the maximum power emitted and different widths of the UHF frequency band dedicated; therefore there is a great number of channels on which the reader can operate.
- At these frequencies (UHF) there are issues not observed at lower frequencies:
 - Reflections: metal structures near the antenna can reflect electromagnetic waves: these reflections can generate areas in which the electromagnetic field is null. The tag in this area would be unreadable.
 - Liquids: electromagnetic absorption by water becomes more consistent. The reading efficiency in particularly humid environments or of tagged objects containing liquids can be difficult.

The transmission speed is higher than that of systems operating at lower frequencies. The systems, moreover, are able to manage multiple readings (more than 100 tags per second). The characteristics (technological and of the anti-collision algorithms) of tags conform to the EPC Class1/Gen2 [10] which should allow, in theory, the reading of 600 (in Europe) and 1500 (USA) tags entering at the same time into the area illuminated by the reader.

In the 2.4 GHz band wireless networks (WLAN, Bluetooth, ZigBee) are already operating. Similarly to HF, these bands are recognized worldwide as frequencies also dedicated to RFID systems. The tags operating at these frequencies have very similar characteristics and behavior to UHF tags and, thanks to the relation between antenna size and wavelength, the size of the antenna tag is in general smaller.

2.1.3 RFID technology

RFID systems have two ways to exchange information, inductive coupling and electromagnetic back-scattered. The inductive coupling between passive tag and reader is realized by coupled coils often referred to generally as “antennas,” to supply the tag with energy needed for the transmission. The two antennas are, from the electrical point of view, tuned LC (inductance–capacitance) circuits and they act as an electrical transformer. The circuit can be summarized as shown in Figure 2.3. The equations (2.1–2.4) characterize the tag resonant frequency, the voltage, and the current induced in the same tag:

$$f_o = \frac{1}{2\pi\sqrt{L_{TAG}C_{TAG}}}, \quad (2.1)$$

$$V_{TAG} = Z_{TAG}I_{TAG}, \quad (2.2)$$

$$I_{TAG} = \frac{j\omega MI_R}{R_{TAG} + Z_{TAG} + j\omega L_{TAG}}, \quad (2.3)$$

$$M = \sqrt{L_{TAG}L_R}. \quad (2.4)$$

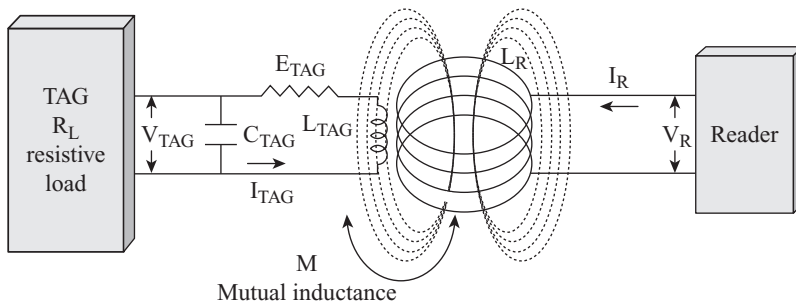

Figure 2.3 Resonant frequency in tags with inductive coupling.

At the resonance frequency the energy transfer between reader and tag is maximized. The formulae (2.2–2.3), showing the voltage and current induced in the tag, indicate that they are proportional to the resonant frequency and to the mutual inductance coefficient (M) between the tag and reader antenna coils.

The communication between reader and tag takes place by modulating the amplitude of the magnetic field generated by the reader antenna with the digital signal that must be transmitted. The receiver circuit of the tag recognizes the modulated field and decodes, from this, the information transmitted by the reader. Now, while on the reader side the energy for transmitting and modulating is not a problem, on the passive tag side it is not the same. The communication back from the tag to the reader is achieved by inductive coupling, as in a transformer in which the secondary winding (coil) varies its load (“load modulation”) and the modulated signal is detected in the primary winding (reader).

In Figure 2.4 a block diagram of a passive tag with inductive coupling is illustrated.

The sequence of events in the reader–tag communication can be summarized as follows:

1. The reader control logic sends the data to the reader transmitter that generates the signal sent to the coils.
2. The current in the reader coil induces a magnetic field that concatenates with the tag coil.
3. A power supply is extracted by the tag circuit that rectifies and limits the received signal.
4. The detector/decoder provides the decoded data to the tag control logic (which can write it into the memory).
5. The detector/decoder indicates to the modulator the instants in which it is possible to enable the transmission back to the reader.
6. The control logic of the tag reads the data in its memory and reports the availability to the modulator which generates the control signal with appropriate timing, actually modulating the impedance of the tag antenna itself.
7. The reader (through the detector) senses the antenna tag impedance changes (since the coils of the antenna tag and reader behave as a transformer as mentioned before) and transmits the received data to its control logic.

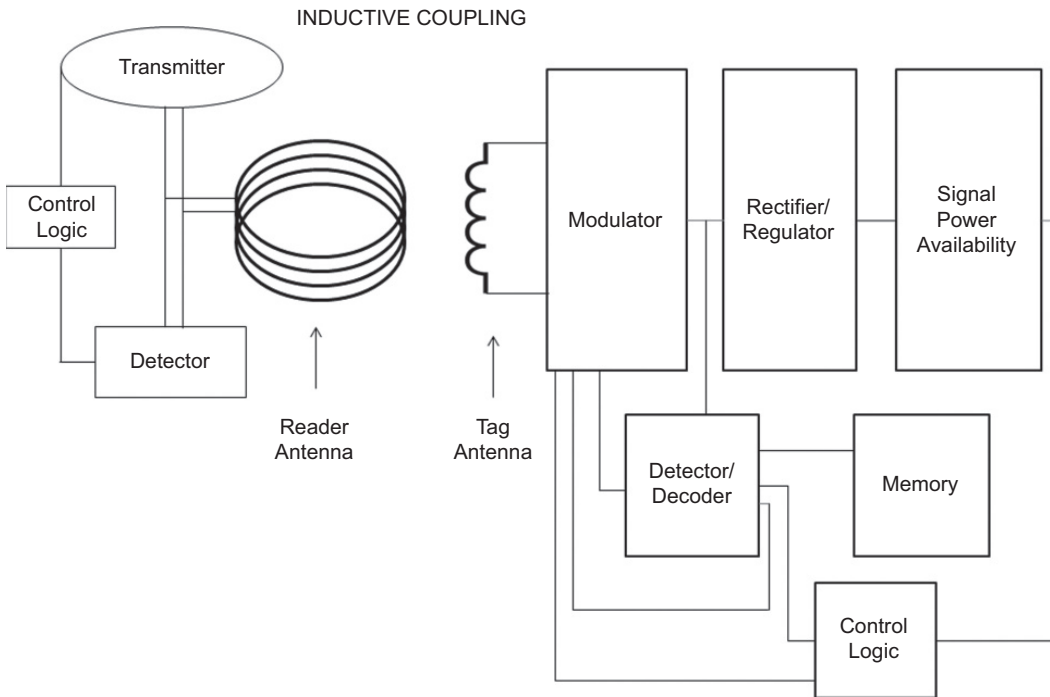

Figure 2.4 Passive tag with inductive coupling.

When an electromagnetic wave hits irregularities in the medium in which it propagates, it disperses randomly. This phenomenon is called scattering. In systems such as radar or RFID, a transmitter sends an electromagnetic wave and a receiver detects the scattering generated from a tagged object on which the wave impacts.

The passive tags that use the back-scatter effect, are therefore designed as a compromise between the capacity to absorb the energy to power up the tag, and the capacity to reflect the incident power, modulating the back-scatter signal, to respond to a query.

The tags operating in UHF or higher frequencies use techniques very similar to the ones used for tags operating at lower frequencies; they receive the power from the EM field emitted by the reader. The difference consists in the way in which energy is transferred and in the fact that antennas instead of coils are used. As mentioned above, the transfer of energy takes place in a “far-field” regime. In this case dipole antennas are usually used as in conventional radio systems. When the EM wave emitted by the reader antenna impinges on the tag, part of the energy is absorbed to provide power to the tag (through an ordinary AC to DC rectifier), but part is reflected back towards the reader as back-scatter.

Even in this case modulation of the back-scatter is obtained by variation of the antenna impedance during the reader transmission. The reader captures the resulting changes in reflected signal. The use of the back-scattered modulation technique in the far field introduces different problems with respect to those occurring in systems at lower frequencies. One is due to the fact that the field emitted by the reader is not only reflected

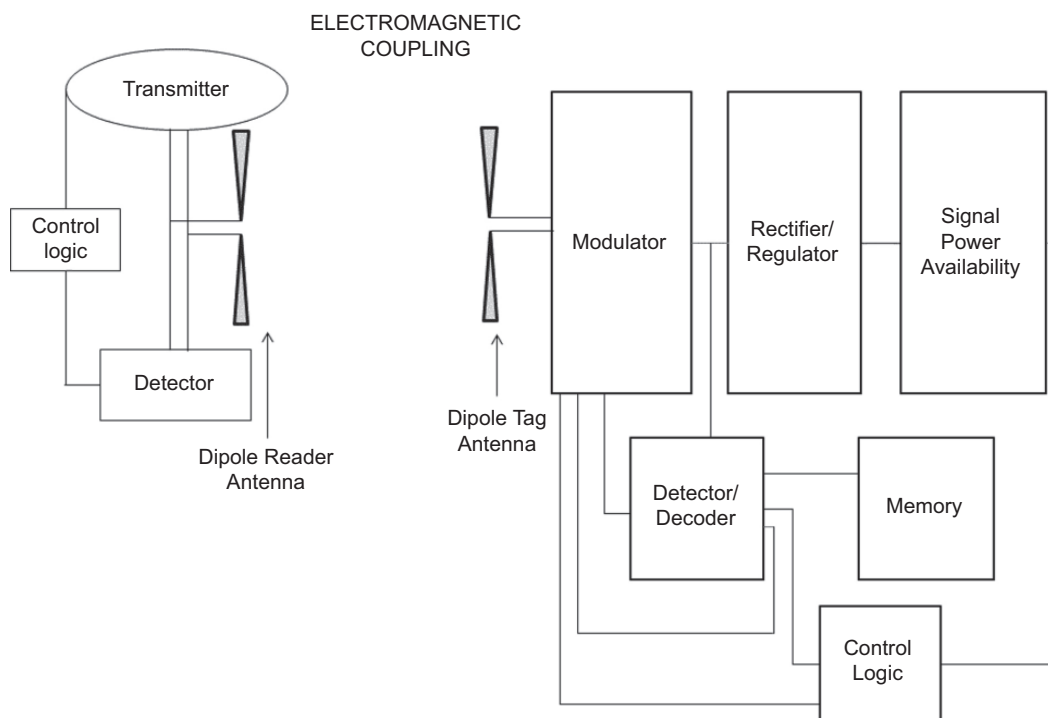

Figure 2.5 Passive tag with electromagnetic back-scattering.

by the tag antenna but also by all the surrounding objects with dimensions comparable to the wavelength employed. This reflected field overlaps the main field emitted by the reader and can cause damping or even cancellation.

The high frequency (UHF, SHF) passive tags operate on distances greater than those inductively coupled and have simpler antennas. Figure 2.5 shows a block diagram of a passive tag with electromagnetic coupling running (in back-scattering) in the UHF band.

In summary, the sequence of events in the query in the back-scatter tag by the reader is as follows:

1. The control logic of the reader sends the data to the transmitter that generates the RF signal to the dipole tag antenna.
2. The signal propagates in space (far-field) and is received by the dipole tag antenna.
3. A power supply is extracted by a rectifier/limiter circuit.
4. The detector/decoder provides the decoded data to the control logic (which eventually will write it into the memory).
5. The detector/decoder signals the oscillator that drives the modulator the instants in which it is possible to activate the transmission of data to the reader.
6. The control logic of the tag reads the data in its memory and communicates the availability to the oscillator that generates the driving signal of the modulator with specific timing (modulates the impedance of the tag antenna recognizing the back-scatter).

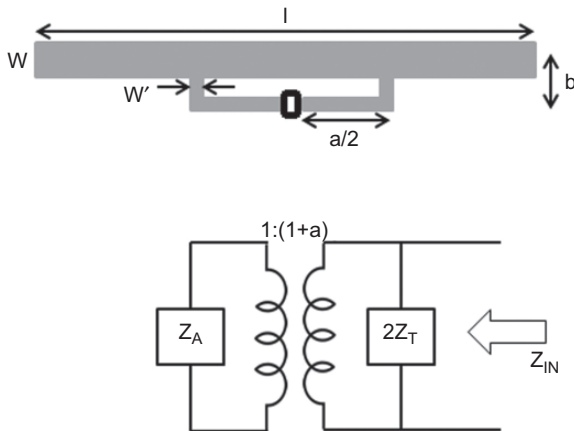

Figure 2.6 The T-match structure and the equivalent circuit.

7. The reader receives the back-scattered signal, decodes it through the receiver and transmits the received data to the control logic.

2.2 Fundamentals and advances in RFID antenna design

In an RFID system the antenna design is critical to ensure an optimized linkage performance. The tag and antenna design adopted for RFID systems is inspired by radar technology in which a reader transmits a signal to a tag and the tag sends back recorded data to the reader. Various aspects need to be considered in the design: the operating frequency, the antenna chip impedance, the overall size, the antenna gain and directivity, the reading range, and so on. Particular attention has also to be paid to the actual environment that affects the near-field region of reader and tag antennas.

In this section the RFID antenna impedance-matching techniques will be summarized by following the guidelines given in [11]. Simulations results, showing how the physical parameters influence the resistance and reactance value of the input impedance, will be described by the use of matching charts. For each design solution, the role of the main geometrical parameters over the complex impedance tuning is examined.

Because of the integrated on-chip energy-storage device, most of the available passive RFID IC chips exhibit an input capacitive reactance roughly ranging from $100\ \Omega$ to $400\ \Omega$ [7], while the real part is about an order-of-magnitude smaller. The tag antenna impedance should be inductive in order to achieve conjugate matching. To obtain low cost devices, it is not feasible to use external matching networks involving lumped components. Therefore, the matching mechanisms have to be embedded within the tag's antenna layout.

To introduce tunable parameters to a dipole of length l , a centered short-circuit stub and a second dipole of length a are added, forming the T-match structure. The IC chip is connected to the second dipole with a distance b from the larger dipole. T-match acts as an impedance transformer, as shown in Figure 2.6.

The impedance at the source point is given by [12] and given in [11]:

$$Z_{in} = \frac{2Z_t(1+a)^2 Z_A}{2Z_t + (1+a)^2 Z_A}, \quad (2.5)$$

$$Z_t = jZ_0 \tan ka/2, \quad (2.6)$$

$$Z_0 = 276 \log_{10}(b/\sqrt{r_e r_{e'}}), \quad (2.7)$$

$$r_e = 0.25w, \quad (2.8)$$

$$r_{e'} = 8.25w', \quad (2.9)$$

$$\alpha = \ln(b/r_{e'})/\ln(b/r_e), \quad (2.10)$$

$$w/w' = 2. \quad (2.11)$$

Where, as reported in [7], (2.6) shows the input impedance of the short-circuit stub formed by the T-match conductors and part of the dipole; (2.7) reports the characteristic impedance of the two-conductor transmission line with spacing b ; Z_A is the dipole impedance taken at its center in the absence of the T-match connection; (2.8) is the equivalent radius of the dipole, and (2.9) is the equivalent radius of the matching stub; (2.10) is the current division factor between the two conductors. The challenge is to give dimensions to a , b , and w' in order to match the antenna impedance to the complex chip impedance, Z_{chip} . Figure 2.7 shows the matching charts for the T-match structure. The ratio between the dipoles' cross-sections has been fixed to be as shown in (2.11).

It can be observed that even with small values of a and b , high values of input resistance are observed. This makes it difficult to match the impedance to IC chips. Therefore, a single T-match structure may not be capable of providing proper impedance matching.

The coupled structure consists of a feed loop with two terminals and a radiating body. The two terminals of the loop are connected to the IC, and the feed "communicates" with the antenna body through mutual coupling.

The inductively coupled structure can be modeled as a transformer. Figure 2.8 depicts the equivalent lumped element model, where R_{rb} and R_{loop} are the individual resistances of the radiating body and the feed loop. M is the mutual inductance and L_{loop} is the self-inductance of the feed loop.

Figure 2.9 shows the matching charts. The input reactance is nearly unaffected by the loop–dipole distance d . For a fixed loop size, the resistance reduces when the loop–dipole distance increases. Therefore, inductively coupled feeding structures present one of the theoretical optimum solutions to effectively match an antenna to arbitrary chip impedances.

A useful matching technique for tags fabricated with large planar dipoles is to employ a nested-slot structure, as shown in Figure 2.10, where by slot we mean an aperture or a window made by removing the area from the solid metal surface. The slot introduces an inductive component able to cancel the capacitive part of the chip impedance.

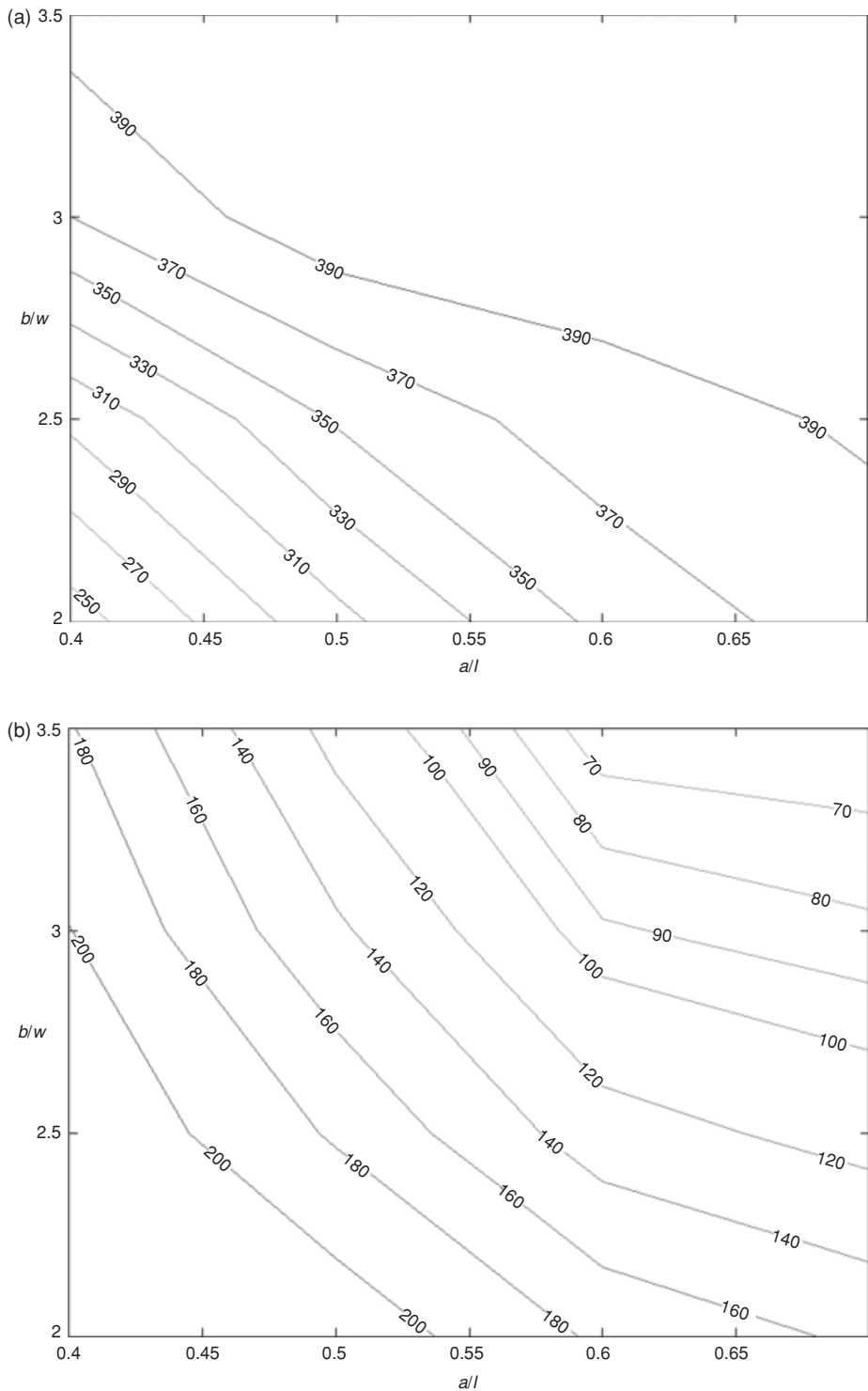

Figure 2.7 The T-match structure matching chart for the case of $l = \lambda/2$, $w = \lambda/100$, $w' = w/2$, (a) resistance (Ω) (b) reactance (Ω).

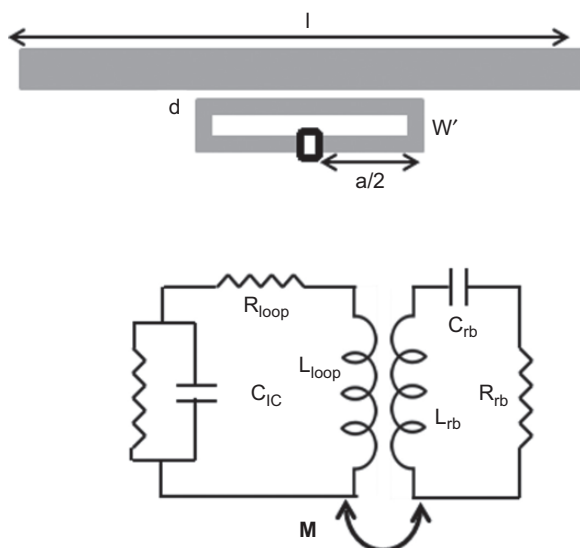

Figure 2.8 Layout of inductively coupled field and equivalent circuit.

Figure 2.11 shows the matching charts of the nested-slot structure. It can be seen that the resistance appears to be sensitive mainly to the slot's width b , while the reactance changes almost linearly along with the sizes of both a and b .

Together with impedance matching optimization, the reduction of the antenna size is assuming a relevant importance in design for applications that require low profile, light, portable RFID equipment. Two efficient ways to reduce size are usually adopted: the introduction of meander lines [12] and the application of the “inverted-F” structure [13].

With the increasing development of wireless technologies and application fields, the need to meet challenging requirements is continually becoming more critical.

As mentioned before, the polarization mismatch can lower the power received by the tag and reader, with a consequent degradation of the system quality. To avoid this phenomenon and to optimize the impedance matching, the reader antenna polarization is being kept circular. Moreover, the number of different frequency bands adopted for RFID communications in different countries is leading to the necessity of having tag antennas able to work at different frequencies by being multiband or at least dual band [14, 15].

2.3 Smart RFID tagged objects: from conventional RFID to networked RFID systems and green solutions

RFID is one of the key elements of the upcoming IoT (Internet of Things); it is often said that RFID is an enabling technology for IoT. This is because IoT is actually based on networked objects and yields simple and cost-effective systems able to connect them.

The conventional RFID structure is mutating toward innovative system architectures that will better fit the requirements of the next generation of pervasive networked and

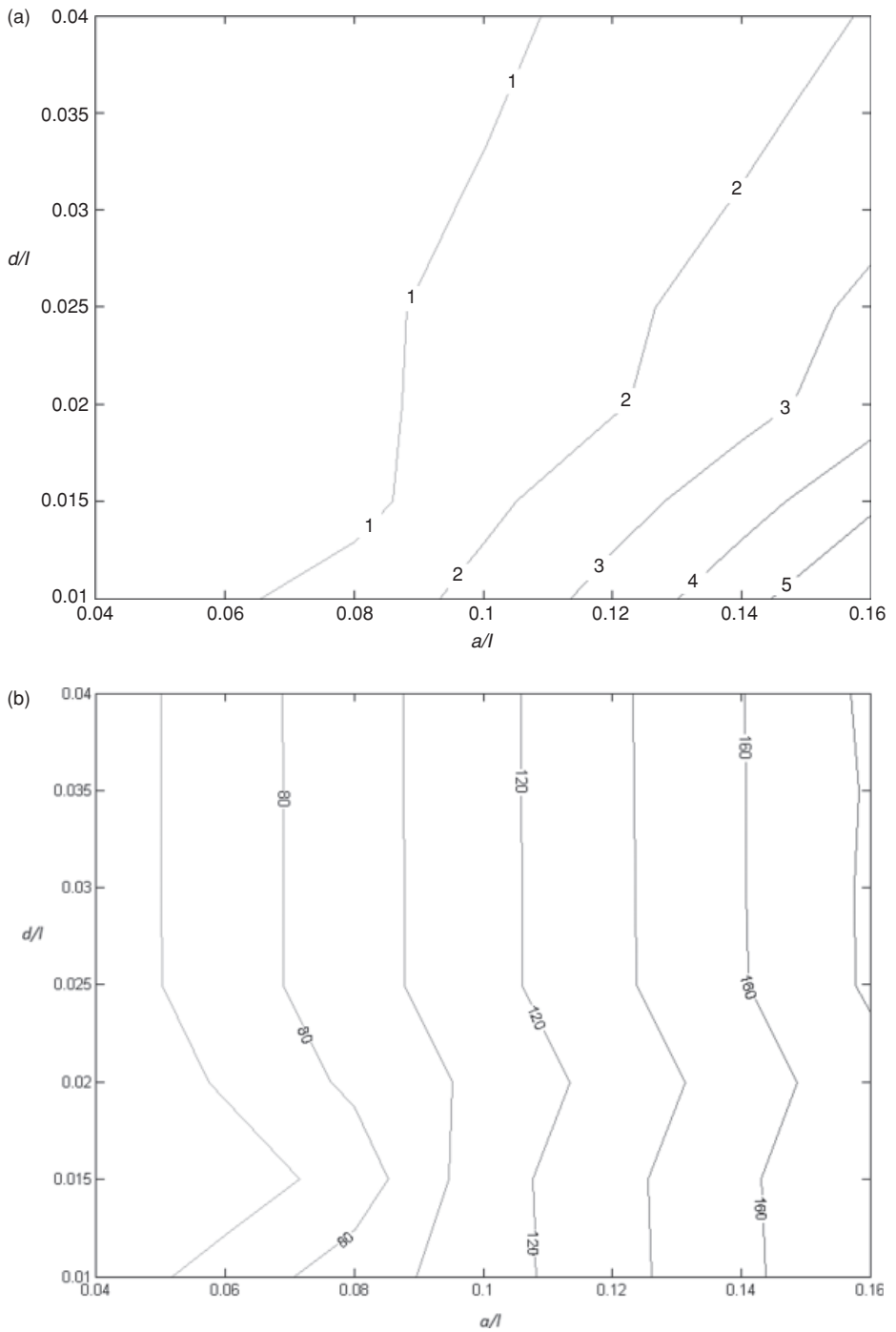

Figure 2.9 The inductive-coupled structure matching chart for the case of $a = b$, $l = \lambda/2$, $w = \lambda/100$, $w' = w/2$: (a) resistance (Ω) (b) reactance (Ω).

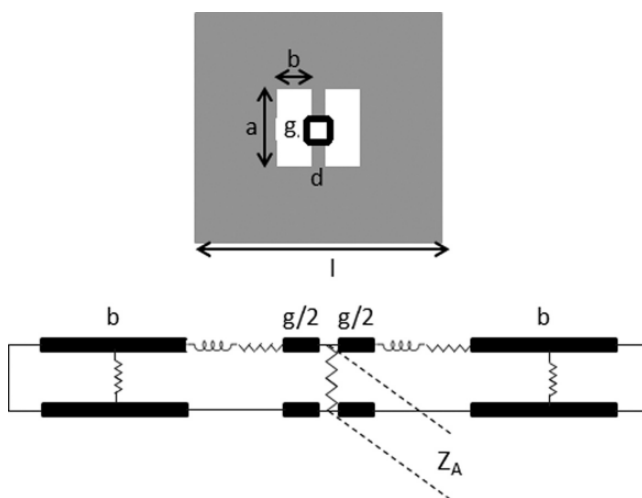

Figure 2.10 The nested-slot structure and the equivalent circuit.

interconnected systems. The global interconnections will need to support an expanding amount of information about identity, location, environmental conditions, and history of all the objects connected to the internet.

The first development that will help this evolution is the creation of systems able to sense, monitor, and adapt themselves to the surrounding environment; such systems can be called “smart RFID tags.” All these features need to be combined into a single device that has to be as small as possible in order to be hosted by as many objects as possible.

Integration of smart devices into “things” implies the integration of chips and antennas into nonstandard substrates. It can be achieved by adopting System in Package (SiP) and System in Package on Paper (SiPoP) [16] technologies or similar; those technologies, in fact, based on the realization of controlled multilayer, heterogeneous, 3D structures, make feasible the low cost integration of antennas, lumped components as well as distributed circuits on a variety of materials (ceramic, liquid crystal polymers – LCP [17–19], paper and so on).

In order to achieve and guarantee an appropriate reading accuracy and reliable data transmission, the RFID tags on connected objects need to be as immune or adaptable as possible to the environmental conditions that can be hostile for electronic circuits. New solutions to implement insensitive/tolerant platforms are under investigation [20, 21]. First, the use of radiating elements placed above ground planes has been adopted; good impedance matching to the RFID chip and relatively high reading range are achieved, even when the tag is attached to lossy or conducting bodies. Second, the development of platform tolerant tags and RFID systems has been proposed for medical applications; platform tolerant tag designs are realized and measured to validate the performance of the tag in a human body.

A remaining big challenge for major development of IoT technologies is to enable operability between objects. Future tags must integrate different standards of

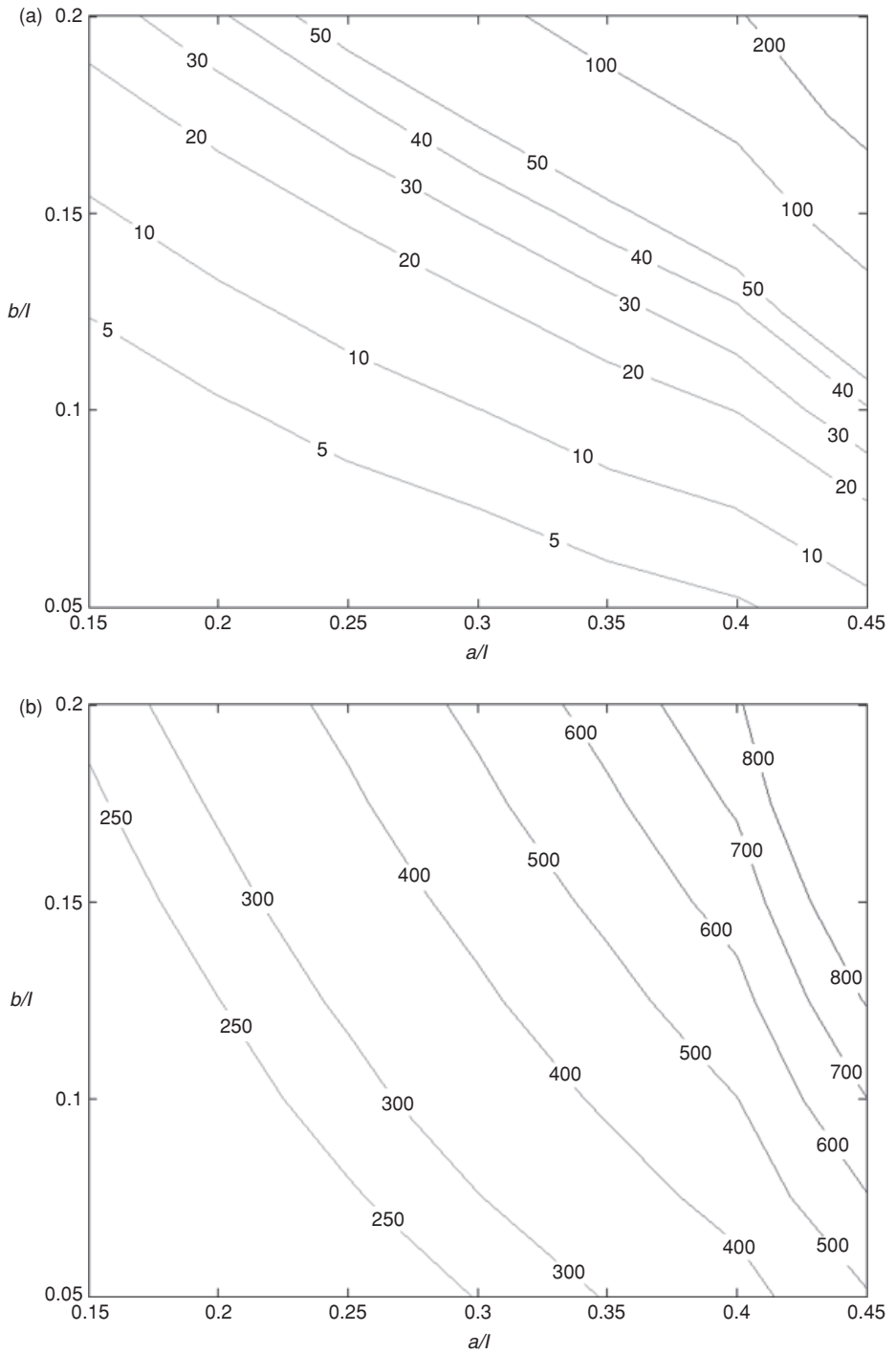

Figure 2.11 The nested-slot structure matching chart for the case of $l = \lambda/2$, $d = g = \lambda/120$, (a) resistance (Ω) (b) reactance (Ω).

communication to allow connection between different architectures, centralized or distributed, if a global standard cannot be established.

The main developments that will animate modern societies and technologies in the future are strongly related to cognitive intelligence and ubiquitous ad hoc networks in many different applications, such as logistics, anti-counterfeiting, supply chain monitoring, space, healthcare, pharmaceutical, military, etc. [22].

Regarding technological evolution, the increasing demand for low cost, flexible, reliable, low power consumption, and durable wireless modules and electronics is steering research towards the development of flexible devices, based on organic materials and substrates, with the goal of overcoming the limitations of ceramics, plastics, and silicon.

In this scenario, paper is an outstanding candidate as a low-cost substrate for radio frequency identification (RFID) and other RF applications. Paper, an organic-based substrate, is universally available and extremely cheap.

Paper also has many characteristics that make it suitable for a variety of applications; the most relevant is its low surface profile that makes paper suitable for fast printing processes such as direct write methodologies or inkjet printing of electronics instead of the traditional metal etching techniques. The combined use of inkjet printing, and other appropriate interconnecting technologies [23] can lead to the production of multi-layer electronics in paper [24], theoretically enabling components such as antennas, ICs, memories, batteries, and sensors to be embedded in paper modules. A further achievement of inkjet printing technology is the printing of conductive polymers and functional materials on cellulose-based substrates (CBS). Organic materials can be printed and patterned using techniques such as flexo, gravure, offset, screen, inkjet, etc. [25–27].

Following these trends, mainly passive devices such as low-cost RFID transponders, sensors, memories, photo-voltaic cells, displays, or batteries have been developed for paper substrate integration, while the development of electronic components such as diodes and transistors has been demonstrated, so far, only in low UHF (RF) bands [28–31].

Consideration of future mass industrial production underlines again the importance of antenna design that is clearly to be the most critical element in terms of costs and dimensions. Antenna dimensions, in fact, determine the amount of substrate material to be manufactured and the quantity of conductive ink to be used in printing processes. Therefore, cost reduction of a tag device has to be achieved by antenna design optimization, meaning reduction of the antenna size for a certain fixed frequency [30] and reduction of ink used, i.e. a real metalized surface.

Moreover, in order to develop paper-based 3D multilayer circuits, the RF characterization of paper became a must for optimal designs. Some characterization work has been done in frequencies beneath the UHF band [31–34], and recently in or above the UHF band [12, 25]. These techniques can be applied to most of the multilayered materials foreseeable for SiP developments.

Paper-like materials are well suited for reel-to-reel processing of dimensions unthinkable for other materials; this feature, in combination with the development of the inkjet printing process and SiPoP integration at an industrial scale [23] enables a tremendous breakthrough in the mass fabrication of RFID tags for a networked society. This

breakthrough will allow not only mass production of ultra-low-cost devices but also the realization of large arrays of devices thus enabling new solutions based on the wide area electronics (WAE) approach [35–38].

References

- [1] Harry Stockman, “Communication by means of reflected power,” *Proceedings of the IRE*, 1196–1204, (Oct.) 1948.
- [2] D. B. Harris, “Radio transmission systems with modulatable passive responder,” US 2927321, 1960.
- [3] M. W. Cardullo and W. L. Parks, “Transponder apparatus and system,” US 3713148, 1970.
- [4] R. A. Hauslen, “The promise of automatic vehicle identification,” *IEEE Trans. on Vehicular Technology*, **VT-26**, (1), 30–38, (Feb.) 1977.
- [5] M. Hassan, M. Ali, and E. Aktas, “Radio frequency identification (RFID) technologies for locating warehouse resources: A conceptual framework,” *Proceedings of 2012 European Conference on Smart Objects, Systems and Technologies (SmartSysTech)*, pp. 1–20, 12–13 June 2012.
- [6] M. Merenda, C. Felini, and F. G. Della Corte, “Battery-less smart RFID tag with sensor capabilities,” *IEEE International Conference on RFID-Technologies and Applications (RFID-TA)*, pp. 160–164, 5–7 Nov. 2012.
- [7] ISO Standard. <http://www.iso.org/iso/home/standards.htm>.
- [8] EPCglobal, “Radio-frequency identity protocols – HF version 2 RFID – draft version 0.0.9,” EPCglobal Standard, Jul. 2006. [Online]. Available: <http://www.epcglobalinc.org/standards/hfg2/>.
- [9] ISO/IEC SC31/WG 4, “ISO/IEC WD 18000–6 mode3; automatic identification – radio frequency identification for item management part 6: Mode 3 – physical layer, anti-collision system and protocols for ultra high frequency (UHF) systems,” Feb. 2002.
- [10] EPCglobal, “Radio-frequency identity protocols – class-1 generation-2 RFID v1.2.0,” EPCglobal Standard, EPCglobal Inc., Oct. 2008, <http://www.epcglobalinc.org>.
- [11] G. Marrocco, “The art of UHF RFID antenna design: impedance-matching and size-reduction techniques,” *IEEE Antennas and Propagation Magazine*, **50**, (1), 66–79, 2008.
- [12] C. Balanis, *Antenna Theory, Analysis and Design*, 3rd Edn., John Wiley & Sons, Inc. 2005.
- [13] G. Orecchini, F. Alimenti, V. Palazzari, *et al.*, “Design and fabrication of ultra-low cost RFID antennas and tags exploiting paper substrates and ink-jet printing technology,” *IET Microwaves, Antenna and Propagation*, **5**, (8), 993–1001, 2011.
- [14] A. Babar, L. Ukkonen, and L. Sydanheimo, “Dual UHF RFID band miniaturized multi-purpose planar antenna for compact wireless systems,” *International Workshop on Antenna Technology (iWAT)*, pp. 1–4, 2010.
- [15] C. Mariotti, V. Lakafosis, M. M. Tentzeris, and L. Roselli, “An IPv6-enabled wireless shoe-mounted platform for health-monitoring,” *IEEE Topical Conference on Wireless Sensors and Sensor Networks (WiSNet)*, pp. 46–48, 2013.
- [16] F. Lolli, M. Virili, G. Orecchini, *et al.*, “Electromagnetic characterization of paper-glue compound for system-in-package on paper (SiPoP) future developments,” *Microwave and Wireless Components Letters, IEEE*, **22**, (10), 545–547, 2012.

- [17] J.-H. Lee, S. Sarkar, S. Pinel, *et al.*, “3D-SOP millimeter-wave functions for high data rate wireless systems using LTCC and LCP technologies,” *Proceedings 55th Electronic Components and Technology Conference*, pp. 764–768, 2005.
- [18] A. Rida, A. Margomenos, J. S. Lee, *et al.*, “Integrated wideband 2-D and 3-D transitions for millimeter-wave RF front-ends,” *Antennas and Wireless Propagation Letters, IEEE*, **9**, (11), 1080–1083, 2010.
- [19] A. Rida, A. Margomenos, and M. M. Tentzeris, “Novel wideband 3D transitions on liquid crystal polymer for millimeter-wave applications up to 100 GHz,” *Microwave Symposium Digest, MTT '09. IEEE MTT-S International*, pp. 953–956, 2009.
- [20] M. A. Ziai and J. C. Batchelor, “Thin ultra high-frequency platform insensitive radio frequency identification tags,” *Microwaves, Antennas & Propagation, IET*, **4**, (3), 390–398, 2010.
- [21] H. Rajagopalan and Y. Rahmat-Samii, “Platform tolerant and capsule-pill RFID antenna designs: An overview of recent developments at UCLA,” *IEEE International Workshop on Antenna Technology (iWAT)*, pp. 144–147, 2012.
- [22] J. Buckley, Final report of the conference “From RFID to the Internet of Things,” ftp://ftp.cordis.europa.eu/pub/ist/docs/ka4/au_conf670306_buckley_en.pdf, Brussels, Mar. 2006.
- [23] F. Alimenti, M. Virili, G. Orecchini, *et al.*, “A new contactless assembly method for paper substrate antennas and UHF RFID chips,” *IEEE Trans. on Microwave Theory and Technique*, **59**, (3), 2011.
- [24] A. C. Siegel, S. T. Phillips, M. D. Dickey, *et al.*, “Foldable printed circuit boards on paper substrates,” *Advanced Functional Materials*, **20**, (1), 28–35, 2010.
- [25] L. Yang, A. Rida, R. Vyas, and M. M. Tentzeris, “RFID tag and RF structures on a paper substrate using inkjet-printing technology,” *IEEE Trans. on Microwave Theory and Technique*, **55**, (12), 2894–2901, 2007.
- [26] E. Fortunato, N. Correia, P. Barquinha, *et al.*, “High-performance flexible hybrid field-effect transistors based on cellulose fiber paper,” *IEEE Electron Device Lett.*, **29**, (9), 988–990, 2008.
- [27] S. Couderc, O. Ducloux, B. J. Kim, and T. Someya, “A mechanical switch device made of a polyimide-coated microfibrillated cellulose sheet,” *Journal of Micromechanical and Microengineering*, **19**, 1–11, 2009.
- [28] S. Steudel, K. Myny, V. Arkhipov, *et al.*, “50 MHz rectifier based on an organic diode,” *Nature Material*, **4**, 597–600, 2005.
- [29] S. Steudel, S. D. Vusser, K. Myny, *et al.*, “Comparison of organic diode structures regarding high-frequency rectification behavior in radio-frequency identification tags,” *J. Appl. Phys.*, **99**, (11), 114–519, 2006.
- [30] V. Subramanian, J. M. J. Frechet, P. C. Chang, *et al.*, “Progress toward development of all-printed RFID tags: Materials, processes, and devices,” *Proc. IEEE*, **93**, (7), 1330–1333, 2005.
- [31] M. Virili, G. Casula, C. Mariotti, *et al.*, “7.5–15 MHz organic frequency doubler made with pentacene-based diode and paper substrate,” Accepted for publication in the *International Microwave Symposium Digest (MTT)*, 2014 IEEE MTT-S.
- [32] S. Simula, S. Ikalainen, and K. Niskanen, “Measurement of the dielectric properties of paper,” *Journal of Imaging Science and Tech.*, **43**, (5), (Sept.) 1999.
- [33] H. Ichimura, A. Kakimoto, and B. Ichijo, “Dielectric property measurement of insulating paper by the gap variation method,” *IEEE Trans. Parts, Materials and Packaging*, **PMP-4**, (2), (June) 1968.

-
- [34] L. Apekis, C. Christodoulides, and P. Pissis, “Dielectric properties of paper as a function of moisture content,” *Dielectric Materials, Measurements and Applications, Fifth International Conference*, pp. 97–100, 27–30 June 1988.
- [35] <http://www.prnewswire.com/news-releases/printed-electronics-for-healthcare-cosmetics-and-pharmaceuticals-2014-2024-226876611.html>.
- [36] <http://www.businesswire.com/news/home/20131125005576/en/Research-Markets-Printed-Electronics-Healthcare-Cosmetics-Pharmaceuticals#.UsbGdNLUKdg>.
- [37] D. Dimitrakopoulos and P. R. L. Malenfant, “Organic thin film transistors for large area electronics,” *Advanced Materials*, **14**, (2), 99–117, (Jan.) 2002.
- [38] A. Nathan, A. Ahnood, T. C. Matthew, *et al.*, “Flexible electronics: the next ubiquitous platform,” *Proc. IEEE (Centennial Issue)*, **100**, 1479–1510, 2012.