

## QSO IDENTIFICATIONS FROM A MOLONGLO RADIO SURVEY

C. HAZARD

Institute of Astronomy, Madingley Road, Cambridge, England.

### THE RADIO SURVEY

For the past few years a co-operative programme involving astronomers at the Universities of Cambridge, Sydney and Groningen and Lick and Steward observatories has been in progress aimed in part at obtaining a complete sample of QSO's in a selected region down to given limits of optical and radio flux. The radio sample from the 408 MHz Mills Cross at Molonglo covers two declination strips each  $2^\circ$  wide and centred at declinations  $\sim 11^\circ\text{N}$  and  $\sim 17^\circ\text{N}$  respectively. Part of the survey has been published as the MC2 and MC3 catalogues (Sutton et al. 1974) covering the  $11^\circ$  strips in the R.A. interval  $11^{\text{h}}28^{\text{m}}-01^{\text{h}}23^{\text{m}}$  and the  $17^\circ$  strip in the interval  $13^{\text{h}}30^{\text{m}}-04^{\text{h}}13^{\text{m}}$  and this section is complete to a flux limit (S) of 0.45 Jy. The rest of the survey consists of an extension of the  $11^\circ$  strip around the rest of the sky and to a lower flux limit of about 0.15 Jy.

### IDENTIFICATION PROGRAMME

The regions of sky around the sources are being examined on the Palomar Sky Survey prints and all objects above the plate limits which can be considered identifications on the basis of their positional agreement are listed and their optical positions measured to an accuracy of better than 1 arc sec. The search areas around each source are determined mainly by the estimated errors in the radio positions ( $\pm 5''$  for  $S \geq 1$  Jy increasing to  $\pm 15''$  for  $S \sim 0.45$  Jy) but allowance has been made also for real optical-radio position differences. Identifications in general have been suggested only for BSO's brighter than  $19^{\text{m}}.5$  and galaxies  $< 18.5$  but a few fainter objects have been identified for some of the stronger sources. From random counts in the area of the survey we estimate that these identifications will have a reliability of at least 90%. With the relatively large search areas there should be little discrimination against even large real optical-radio displacements arising due to extended asymmetric structure. It must be emphasized that this is the first stage of the identification procedure.

For objects not identified at this stage more accurate positions are being obtained at Westerbork and NRAO and structures and spectra are being obtained at Westerbork and Cambridge for at least the more interesting of the confirmed identifications. Even in the early stages of the spectroscopic work attention is not being confined to the suggested identifications (although these naturally have the highest priority) but many of the neutral and red stellar objects close to the radio positions are being observed. So far these observations suggest that such objects will not significantly increase the number of QSO's over that obtained by concentrating on blue objects alone although of course they may include some of the interesting objects at very high redshift ( $z$ ). The majority have turned out to be either galactic stars or BL Lac type objects although in the extension of the  $11^{\circ}$  survey an interesting high redshift red QSO with  $z = 3.27$  has been found (Beaver et al. 1976). This, however, is an unusual object with the red colour due to a steep optical continuum and strong CIV emission which at  $z = 3.27$  falls near the peak response of the Palomar E-print. A second interesting identification this time with a neutral stellar object is 1400+162, identified with a BL Lac object in a cluster of galaxies. Weak narrow emission lines give a redshift of 0.24, the same as the nearest cluster galaxy, thus confirming it as a cluster member. Its radio structure is particularly interesting, consisting of a flat spectrum compact component and steep spectrum extended structure some  $25''$  in extent symmetrically placed about the central component. At low frequencies it would appear as a symmetrical type double source. This is a typical QSO structure and links the BL Lac objects to the QSO's and suggests that fundamentally they are similar objects.

#### OPTICAL STUDIES

The optical work is most complete for the sources in the MC2 and MC3 catalogues and particularly in the R.A. interval  $11^{\text{h}}30^{\text{m}}-17^{\text{h}}$ . Table 1 shows the distribution in R.A. of the suggested BSO identifications in this part of the survey and also the number so far confirmed as identifications, mainly by spectroscopic studies but in a few cases by accurate Westerbork positions. The results for the  $11^{\text{h}}30^{\text{m}}-17^{\text{h}}$  region confirm that the reliability of the identifications is indeed of the order of 90%.

It is noticeable that the BSO density appears particularly high for the intervals  $11^{\text{h}}30^{\text{m}}-12^{\text{h}}30^{\text{m}}$  and  $17^{\text{h}}-18^{\text{m}}$ . While the high density in the latter region must be suspect because of its proximity to the galactic plane all but one of the identifications between  $11^{\text{h}}30^{\text{m}}$  and  $12^{\text{h}}30^{\text{m}}$  have now been verified. In this interval 36% of the sources are QSO's compared with a 20% BSO content for the survey as a whole. In fact the majority of the identifications in this early part of the survey lie between  $11^{\text{h}}46^{\text{m}}$  and  $12^{\text{h}}21^{\text{m}}$  where there are 10 QSO's out of a total of 20 sources. In contrast between  $13^{\text{h}}35^{\text{m}}$  and  $14^{\text{h}}15^{\text{m}}$ , a much larger area since it includes both declination strips, there is only one suggested BSO identification. While the data are too scanty to reach any definite

R.A.	11 <sup>o</sup>			17 <sup>o</sup>		
	N <sub>s</sub>	BSO's	QSO's	N <sub>s</sub>	BSO's	QSO's
11 <sup>h</sup> 30 <sup>m</sup> - 12 <sup>h</sup> 30 <sup>m</sup>	33	12*	11	—	—	—
12 30 - 13 30	36	8	7	—	—	—
13 30 - 14 30	24	3	1	30	7	4
14 30 - 15 30	41	8*	6	43	8*	6
15 30 - 16 30	28	5	5	40	4	4
16 30 - 17 00	15	3*	1	18	6	3
Totals	177	39	31	131	25	17
17 00 - 18 00	38	13	1	45	17*	1
20 20 - 21 20	34	6	—	29	11*	1
21 20 - 22 20	22	5	3	32	6	4
22 20 - 23 20	32	3	2	26	2	1
23 20 - 00 00	17	3	2	14	2*	1
Totals	143	30	8	146	38	8

Table 1. Summary of MC2 and MC3 identification data. An asterisk indicates that one of the BSO's has been shown to be a galactic star.

conclusions they do at least suggest the possibility that the QSO distribution may be non-uniform on a scale of 20<sup>o</sup>-30<sup>o</sup>.

Figure 1 shows the magnitude distribution for all BSO's suggested as identifications up to 17<sup>h</sup> R.A. and for comparison the magnitude distribution for the 3C sample of Schmidt (1970) and the 4C sample of Lynds and Wills (1972). All three show the familiar peak in the distribution well above the plate limits. I emphasize that this peak is a real feature of the distributions since when galaxy identifications are taken into account there are just insufficient sources for omitted identifications to greatly change the results although no doubt the steepness of the decrease to fainter magnitudes is exaggerated. This is an important feature since it means that at least for sources >0.45 Jy at 408 MHz the counts of BSO's <19<sup>m</sup>.5 in different areas will not be greatly affected by either high galactic latitude obscuration or variations in the print sensitivities. There is, however, clear evidence of a shift of the peak to fainter magnitudes with decreasing radio flux.

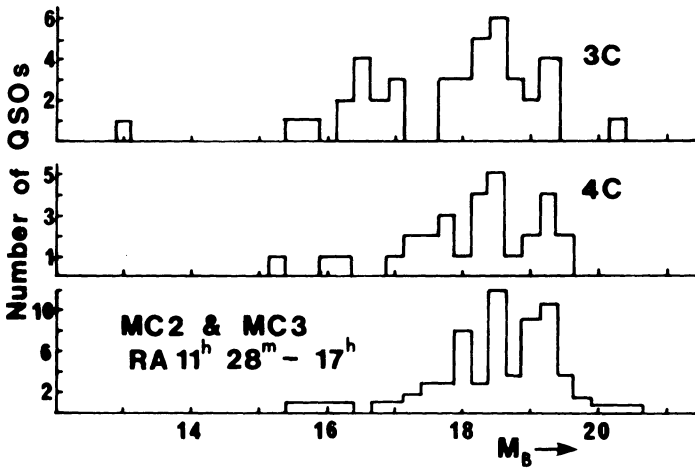

Figure 1. Magnitude distributions of 3C, 4C and MC2 and MC3 QSO's up to  $17^{\text{h}}$  R.A.

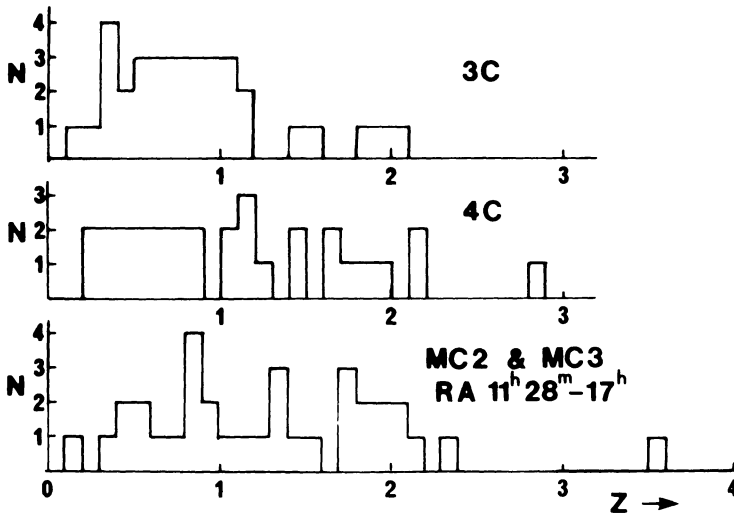

Figure 2. Redshift distributions of 3C, 4C and MC2 and MC3 QSO's up to  $17^{\text{h}}$  R.A.

The redshift distributions shown in Figure 2 also show evidence of a shift to higher values of  $z$  between the strong 3C sources and the weaker 4C and Molonglo samples. The difference between the latter

samples, however, is scarcely significant. Neither is there a significant difference between the  $z$  distributions for Molonglo sources with  $S > 1$  Jy and those with  $S < 1$  Jy.

The scarcity of objects with  $z \geq 2.2$  is obvious and again it must be emphasized that this is almost certainly a real effect. There are no colour selection effects which would prevent the detection of high  $z$  objects at least up to  $z \sim 3.5$  except in the case of unusual objects such as 0938+119. Furthermore once identified the redshifts of such objects are generally simple to determine because of the presence of strong Ly- $\alpha$  in the majority. The relative absence of high  $z$  objects is shown more clearly in Figure 3(a) which gives the  $z$  distribution for all objects for which redshifts are available in the MC2 and MC3 catalogues. Our failure to detect high  $z$  objects ( $z \geq 3$ ) after our initial successes some years ago has been disappointing since we then confidently expected that at least among the neutral St objects we would find many further examples. However, most such objects have turned out to be continuum spectrum objects although one or two low redshift QSO's have also been found among them.

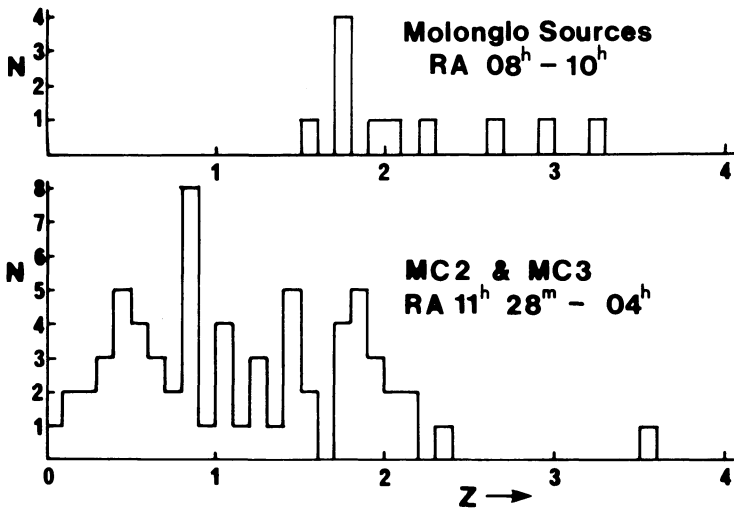

Figure 3. Redshift distributions for all MC2 and MC3 QSO's and for a sample of weak source around  $08^h-10^h$  R.A.

We have recently started to examine the extension of the  $11^0$  survey in the region of R.A.  $08^h-10^h$  and the present results shown in Figure 3(b) are surprising. In contrast to the MC2 and MC3 regions where only one third of the QSO's have  $z \geq 1.5$  all of the objects so far examined in the  $08^h-10^h$  region have  $z > 1.5$ . It does not appear that this result can be attributed solely to the lower flux limit of the new survey since all of the objects with  $z > 2$  have  $S > 0.45$  Jy and could have been included if present in the MC2 and MC3 sample. However, it

may be that there is a bigger dependence of redshift on flux than appears from the early results. Alternatively, the result may provide further evidence for a clustering of QSO's.

While it is clear that with the relatively scanty and incomplete data available it is premature to take seriously the evidence for QSO clustering it seems to me that if the paucity of QSO's beyond  $z \approx 2.2$  and the steep density evolution proposed by Schmidt are real such clustering would not be too surprising. Nor would regions of high  $z$  QSO's. The paucity of QSO's with  $z \approx 2.2$  can be interpreted as representing a real switch in time of QSO's or at least an epoch of maximum QSO formation whose onset is determined by the properties of the Universe at that time. Density perturbations and quite small differences in the expansion velocity about the mean would then imply different switch on times on different regions. When followed by steep density evolution this would lead to drastic differences in the density of QSO's in different regions the QSO's being a particularly sensitive indicator of the conditions in the Universe. Nearby regions which switched on early would now be deficient QSO's while high  $z$  objects would be found only in those distant regions where the QSO formation occurred earlier than the average. A completely uniform density of QSO's would certainly require a remarkable uniformity of the effective age of the Universe in unconnected regions. The uniformity of the  $3^\circ$  black body radiation of course argues for this high degree of uniformity and any observed density fluctuations in the QSO distribution must be reconciled with the isotropic background and also the apparently isotropic distribution of the radio sources in general.

### Acknowledgements

The identifications discussed in this paper have been carried in collaboration with H. S. Murdoch. The author also acknowledges the contributions of all the other participants in the programme and the support of NATO grant No 647.

### References

- Beaver, E. A., Harms, R., Hazard, C., Murdoch, H.S., Carswell, R. F. and Strittmatter, P. A. : 1976, *Astrophys. J. (Letters)*, 203, L5.
- Lynds, R. and Wills, D. : 1972, *Astrophys. J.*, 172, 531.
- Schmidt, M. : 1968, *Astrophys. J.*, 151, 393.
- Sutton, J. M., Davies, I. M., Little, A. G. and Murdoch, H. S. : 1974, *Austr. J. Phys. Astrophys. Suppl.* No. 33.

## DISCUSSION

*Grueff:* I would like to comment on the lack of optically faint quasars present in radio-catalogues. It is certainly true that the distribution of optical magnitudes for quasars in the 3C catalogue is tapering down well before the P.S.S. plate limit, with a peak value at about  $m_v = 18$ . However, for B2 sources stronger than about 1 Jy, the same distribution is peaked at about  $m_v = 19$ . Further, there is evidence that at  $S_{408} \sim 0.2$  Jy a large fraction of quasars can have  $m_v > 20.5$ .

*Hazard:* I agree that the peak of the distribution shifts to fainter magnitudes with decreasing radio flux. This shift is clearly apparent between the 3C sample and the Molonglo sample.

*Miley:* What is the flux ratio of the components of your 60" quasar with a redshift of 2?

*Hazard:* Roughly equal.

*Miley:* So in this case the identification wouldn't have been missed by merely using the position of the centroid?

*Hazard:* No.

*M.G. Smith:* Kristian and Hazard have re-emphasised Bolton's point that there is a shortage of optically faint QSOs in the radio catalogues. However, according to unpublished work by Hoag and Weedman, faint QSOs do exist in large numbers at faint magnitudes. Even in the restricted redshift range from 1.7 to 3.3, they find more than a dozen QSOs per square degree in the magnitude range 18.5 to 21. Can Margaret Burbidge or Gene Smith comment on the magnitude distribution in this sample?

*Hazard:* The radio samples I discussed have a radio flux limit of about 0.5 Jy at 408 MHz compared with a limit of 9 Jy at 178 MHz for the 3C Survey, and show a significant shift of the peak in the magnitude distribution towards fainter magnitudes. No doubt as the flux limit is reduced, fainter QSOs will become more frequent among the radio selected objects and indeed there are already many around  $20^m$  in the Molonglo sample. My point was that irrespective of the reasons for it, above 0.5 Jy the peak must be genuine although the steepness of the fall at fainter magnitudes will be somewhat exaggerated. Thus, provided counts are complete to around  $19.5^m$  the numbers of BSOs counted in different regions cannot be greatly affected by high galactic latitude obscuration or print to print variations in the sensitivity of the Palomar Survey, certainly not by factors of the order of 2.