

Non-digestible fraction of beans (*Phaseolus vulgaris* L.) modulates signalling pathway genes at an early stage of colon cancer in Sprague–Dawley rats

Vergara-Castañeda Haydé¹, Guevara-González Ramón², Guevara-Olvera Lorenzo³, Oomah B. Dave⁴, Reynoso-Camacho Rosalía¹, Wiersma Paul⁴ and Loarca-Piña Guadalupe^{1*}

¹Programa de Posgrado en Alimentos del Centro de la República (PROPAC), Research and Graduate Studies in Food Science, School of Chemistry, Querétaro State University, Cerro de las Campanas S/N Col. Las Campanas, Querétaro, Qro. 76010, Mexico

²School of Engineering, Laboratory of Biosystems, Querétaro State University, Querétaro, Qro. 76010, Mexico

³Biochemistry Engineering, Instituto Tecnológico de Celaya, Guanajuato, Mexico

⁴Agriculture and Agri-Food Canada, Pacific Agri-Food Research Centre, Summerland, BC, Canada V0H 1Z0

(Submitted 31 August 2011 – Accepted 26 October 2011)

Abstract

Colorectal cancer is one of the most common causes of morbidity and mortality in Western countries, the second cause of cancer mortality in the USA and a major public health problem in Mexico. A diet rich in legumes is directly related to the prevention of colon cancer, showing an inverse relationship with the development of colorectal adenomas in human subjects. The present study shows the results of molecular changes involved in the *Tp53* pathway at an early stage in the distal colon tissue of azoxymethane (AOM)-induced colon cancer in rats evaluated by PCR array after exposure to diets containing the non-digestible fraction (NDF) of cooked bean (cultivar Bayo Madero). Significant differences were detected in seventy-two genes of the *Tp53*-mediated signalling pathway involved in apoptosis, cell-cycle regulation and arrest, inhibition of proliferation and inflammation, and DNA repair. *Tp53*, *Gadd45a*, *Cdkn1a* and *Bax* were highly expressed (9·3-, 18·3-, 5·5- and 3·5-fold, respectively) in the NDF + AOM group, whereas *Cdc25c*, *Ccne2*, *E2f1* and *Bcl2* were significantly suppressed (–9·2-, –2·6-, –18·4- and –3·5-fold, respectively), among other genes, compared with the AOM group, suggesting that chemoprevention of aberrant crypt foci results from a combination of cell-cycle arrest in G1/S and G2/M phases and cell death by apoptotic induction. We demonstrate that the NDF from common bean modulates gene expression profiles in the colon tissue of AOM-induced rats, contributing to the chemoprotective effect of common bean on early-stage colon cancer.

Key words: Colon cancer: Common beans: Non-digestible fractions: Quantitative PCR array: Gene expression: *Phaseolus vulgaris*

Colorectal cancer is the third most common cancer in terms of incidence and mortality in several Western industrialised countries. Thus, every year, nearly one million people worldwide develop colorectal cancer⁽¹⁾. In the USA, incidence of and mortality from colorectal cancer are estimated at approximately 9%, accounting for 51 370 estimated deaths and 102 900 new cases per year⁽²⁾. In 2006, malignant tumours were the third highest cause of death in Mexico, with colon cancer contributing to 5·0 and 4·6% for men and women, respectively⁽³⁾. Proper nutrition is essential for cancer prevention due to the physiological and biological properties of endogenous phytochemical compounds present in the diet. Epidemiological studies have also shown that the importance of diet in the prevention and/or development of cancer was directly associated with the

consumption of fruits, vegetables and legumes^(4,5). A high consumption of legumes, such as common beans, has been inversely related to advanced adenoma recurrence in human subjects⁽⁶⁾. Common beans (*Phaseolus vulgaris* L.) generally contain considerable amounts of non-digestible fraction (NDF) consisting of soluble and insoluble fibres, resistant starch, oligosaccharides, phenolic compounds⁽⁷⁾ and probably bioactive peptides released in the colon⁽⁸⁾.

The NDF from common bean can be fermented in the large intestine exerting several physiological effects through the production of SCFA, mainly butyrate, propionate, acetate^(9,10), as well as some hydroxyl acids produced from phenolic compounds⁽¹¹⁾ or by the direct action of compounds that constitute the NDF matrix on several molecular pathways^(8,12).

Abbreviations: AOM, azoxymethane; cDNA, complementary DNA; cv., cultivar; NDF, non-digestible fraction.

* **Corresponding author:** L.-P. Guadalupe, fax +52 442 192 1307, email loarca@uaq.mx

Our previous studies^(13,14) demonstrated that the polysaccharide extract or the NDF of common bean modulates gene expression, thereby exerting protection against colon cancer development. A polysaccharide extract of black bean cultivar (cv.) Negro 8025 reduced aberrant crypt foci development in azoxymethane (AOM)-induced rats and regulated the expression of β -catenin, *p53*, *p21*, *Rb*, *Bax* and caspase-3 (*Casp3*) genes involved in cell proliferation, cellular arrest and apoptosis⁽¹³⁾. The NDF from cream bean cv. Bayo Madero, subjected to a simulated monogastric digestive fermentation process, modulated gene expression involved in cell-cycle arrest, induction of apoptosis and proliferation inhibition in an *in vitro* model of late-stage colon cancer using HT-29 colon adenocarcinoma cells, thus contributing to the chemoprotective effect of common bean against colon cancer development⁽¹⁴⁾. The present study investigated the transcriptional effects of the NDF from common bean cv. Bayo Madero on the gene expression profile in the distal colon tissue of *Tp53* signal transduction in an *in vivo* model of early-stage colon cancer, to elucidate the molecular mechanism involved in the chemopreventive action of common bean.

Experimental methods

Materials

Bean cv. Bayo Madero was harvested in 2007 at the Bajio Experimental Station of the National Research Institute for Forestry, Agriculture and Livestock (INIFAP), Celaya, Guanajuato, Mexico. Seeds were cooked using a 'traditional' cooking process according to the method of Aparicio-Fern ndez *et al.*⁽¹⁵⁾. Male Sprague–Dawley rats were obtained from Harlan, Inc. The care and use of these animals were in compliance with policies and regulations of the Institutional Animal Care and Use Committee of the University of Queretaro, Mexico. AOM was purchased from Sigma Chemical Company.

Non-digestible fraction extraction

The extraction of the NDF was performed following the method of Kurtzman & Halbrook⁽¹⁶⁾. Briefly, water (1.5 litres) was added to 300 g of cooked beans (beans and cooking water) and the mixture was shaken for 1 min and centrifuged (Hermle Z323K; Hermle Labortechnik GmbH) at 9000 **g** for 10 min. The pellet from the first centrifugation was dissolved in 100 ml of 10% tannic acid, adjusted to pH 4 and centrifuged again (9000 **g** for 10 min), and the pellet was washed three times with 100 ml acetone and centrifuged for 10 min after each washing to obtain the NDF. NDF samples were lyophilised and stored in amber flasks at 4°C until further analyses.

Animal and experimental design

Male Sprague–Dawley rats with an initial weight of 69.6 (SD 5) g at 4 weeks of age were used in the present study. The rats were maintained in an air-conditioned animal room at ambient temperature (21 ± 2°C), 55% humidity and a 12 h light–12 h dark cycle and had free access to a basal diet (2018S Harlan Tekland)

and regular tap water. At 1 week after acclimatisation, the rats were randomly placed into two groups (*n* 12): (1) AOM, basal diet plus subcutaneous injection of AOM (15 mg/kg body weight, dissolved in 1 ml of physiological saline) once per week on weeks 3 and 4; distilled water was also administered intragastrically once per d during the experimental period (9 weeks); (2) NDF from common bean cv. Bayo Madero plus AOM and basal diet (NDF + AOM), basal diet plus AOM (once per week on weeks 3 and 4) and NDF (2.5 g/kg body weight) daily for 9 weeks. The NDF, dissolved in distilled water, was administered intragastrically once per d during the experimental period (9 weeks) and the dose was selected according to the rural *per capita* intake of beans in the Lagunera Region of Mexico⁽¹⁷⁾. The animals were killed 5 weeks after the last injection and the distal colons were removed and stored at –70°C until analysis. The colon tissues from four rats were randomly chosen for the isolation of RNA. The results on NDF chemoprotection against lesion development of early-stage colon cancer called aberrant crypt foci in Sprague–Dawley rats have been reported by Vergara-Casta eda *et al.*⁽⁷⁾.

RNA isolation and complementary DNA synthesis

Total RNA from the distal colon tissue of rats induced with AOM and treated with or without the NDF was isolated using an Rneasy Mini Kit (Qiagen) according to the manufacturer's instructions. All RNA samples were examined for the absence of DNA and RNA degradation by denaturing agarose gel electrophoresis. mRNA (1 µg) was reverse transcribed and amplified with the SMART–PCR complementary DNA (cDNA) synthesis kit and the Advantage cDNA PCR kit (Clontech Laboratories, Inc.). First-strand cDNA synthesis was performed according to the manufacturer's instruction and included 1 µg of total RNA, 7 µl cDNA synthesis (CDS) synthesis primer IIA (12 µM), 7 µl SMART II A oligonucleotide (12 µM) and 200 U Superscript II.

Quantitative RT-PCR (quantitative PCR arrays)

Quantitative determination of *Tp53* pathway transcripts was carried out essentially as reported by Campos-Vega *et al.*⁽¹⁴⁾ with slight modifications. Briefly, 46 µl of diluted first-strand cDNA (100 ng/µl) were mixed with the RT2 Real-Time™ SYBR Green/Rox PCR Master Mix (PA-021; SABiosciences). Previously, it was confirmed that 0.5 µl from first-strand cDNA (dilution at 1:1 with free-nuclease water), with the concentration mentioned above, produced the same *C_t* amplification of housekeeping genes included in the PCR array as when using 1 µl. The expression of seventy-seven genes, as a function of the NDF from common bean cv. Bayo Madero treatment, was assessed using the Rat RT2 Profiler real-time PCR array (PARN-027A; SABiosciences), as specified in the manufacturer's user manual. The array included *Tp53*-related genes involved in apoptosis, cell cycle, cell growth, proliferation and differentiation, and DNA repair plus three housekeeping genes. The quantitative PCR was done using the Stratagene Mx 3000P quantitative PCR system (Stratagene) with the following protocol: 95°C, 10 min and then forty cycles of 95°C, 15 s/60°C, 1 min. Data were evaluated with MxPro software (Stratagene).

The SYBR Green–dsDNA complex signal was normalised to the passive reference dye 6-Carboxyl-X-Rhodamine (ROX), included in the SYBR Green PCR Master Mix to correct for well-to-well fluorescent fluctuations. Relative gene expression levels were calculated by the comparative C_t method including normalisation to the constitutively expressed gene and to a control sample. Data were analysed by the PCR array data analysis web portal (<http://www.sabioscience.com/pcr/arrayanalysis.php>), based on the $\Delta\Delta C_t$ method with normalisation of the raw data to either housekeeping genes or an external RNA control. An Excel-based data analysis template was used. We considered sequences as potential target genes if the change between rats treated with NDF + AOM and AOM was greater than 1.1-fold (up- or down-regulated genes; $P \leq 0.05$), following the instruction from the data analysis web portal.

Results

Tp53 gene expression pathway analysis showed that seventy-two genes were modulated at least >1.1-fold (induction or inhibition) in the AOM-induced NDF group (NDF + AOM) compared with the AOM group (Tables 1 and 2). These genes belong to different pathways involved in apoptosis, cell cycle, cell proliferation and differentiation, DNA repair and inflammatory response.

Tp53, a regulator of different checkpoints during the cell cycle in both G1/S and G2/M phases, was overexpressed (9.3-fold) in the NDF + AOM group compared with the AOM group. In addition, *Cdkn1a* (*p21*), participating in the cell-cycle G1/S phase, was also up-regulated (5.5-fold), whereas *Ccne2* (Cyclin E) and *Cdkn2A* were inhibited (–2.6- and –2.4-fold, respectively). *Rb1* (retinoblastoma) and *E2f1*, two important genes involved in this cell-cycle phase, were also suppressed by the NDF treatment (–1.5- and –1.8-fold, respectively). Furthermore, *E2f1* and *Rb1* can also be suppressed by *Dnmt1*, overexpressed (9.3-fold) in the NDF + AOM group compared with the AOM group. *Myod1* was potently suppressed (–11.8-fold).

The NDF + AOM treatment suppressed genes implicated in the G2/M phase of the cell cycle, indicated by a decrease in *Ccnb2* and *Cdc25c* expression (–1.4- and –9.2-fold). Besides, the NDF + AOM group induced *Gadd45a* expression (18.3-fold) and up-regulated the *Sfn* gene (6.7-fold), implicated in cell-cycle arrest at the G2/M phase.

The quantitative PCR array also revealed that some genes involved in DNA repair by different mechanisms were regulated in the NDF + AOM group compared with the AOM group. The expression of these genes including *Pcna*, *Msb2* and *Xrcc5* increased by 4.6-, 1.8- and 3.2-fold, respectively. *Foxo3* can enhance *Pcna* expression and was up-regulated 2.4-fold by the NDF + AOM treatment.

The genes *Bax*, *Bid* and *Bnip3* involved in apoptosis were overexpressed in the NDF + AOM group (3.5-, 1.1- and 3.3-fold, respectively), whereas *Bcl2*, *Apaf1*, *Casp2* and *Casp9* were suppressed (–3.5-, –1.2-, –2.9- and –1.6-fold, respectively) compared with the AOM group. Moreover, *Tp53* induced *Stat1* expression (4.2-fold), which enhanced the apoptotic effect against cell damage, and the *Ras* gene was overexpressed by

5.5-fold in the NDF + AOM group compared with the AOM group. NDF + AOM also regulated the *Tp73l* (p63) (up-regulated by 1.3-fold) and *Tp73* (down-regulated by –12-fold) genes.

Nfkb1, *Tnf* and *Traf1* were overexpressed (3.4-, 2.5- and 2.3-fold, respectively) in the NDF + AOM group compared with the AOM group. In the same inflammation process, *Il6* and *Jun*, induced by *Nfkb1*, were down-regulated by –1.5- and –13.7-fold, respectively, in the NDF + AOM group.

We also observed some contrasting and unexpected results, particularly the overexpression of *Bag1*, *Birc5* and *Mcl1* (13.7-, 3.7- and 7.3-fold, respectively), and the down-regulation of *Rprm* (–3.3-fold) in the NDF + AOM group compared with the AOM group.

Discussion

The present study shows differential regulation in the expression of several inter-related genes, participating in molecular pathways activated by *Tp53* and functioning as a defence stimulus against cell aggression. Their main function is to prevent or delay the development of injuries which could then trigger tumour growth. These results demonstrate the potential of the NDF + AOM treatment in the induced colon tissues to trigger these pathways, and propose the molecular mechanisms preventing the development of colon cancer (Figs. 1–3). AOM was used as a model carcinogenic compound that induced human colon cancer similar to other carcinogens and is an example of non-familial colon cancer in humans. Since the NDF prevented colon cancer induced by AOM in the tested model, the same prevention would be expected from any other carcinogen in humans.

The tumour-suppressor gene *Tp53* activates or suppresses the transcription of target genes involved in the repair of cell injuries in normal conditions or in response to cell stress or genotoxicity^(18,19). The stabilisation and activation of p53 protein is critical in stress response, but since *p53* gene expression is rapid and transient, increasing the transcription rate of the gene is crucial. Moreover, induction of *p53* mRNA levels increases in parallel with the rate of the newly synthesised p53 protein⁽²⁰⁾. In the present study, *Tp53* was overexpressed in the NDF + AOM group compared with the AOM treatment. Our previous studies showed no adverse effects due to NDF treatment in rats without AOM⁽⁷⁾. Moreover, Feregrino-Pérez *et al.*⁽¹³⁾ reported that common beans (*Phaseolus vulgaris* L.) cv. Negro 8025 without AOM did not induce *p53* expression, therefore the modulation of *p53* expression by the NDF treatment may be considered as part of the response to carcinogen and non-NDF. Several genes, such as *Cdkn1a* (*p21*) acting as *Tp53* transcriptional targets leading to a first control point in the G1 phase of the cell cycle⁽²¹⁾, were up-regulated, whereas *Ccne2* (Cyclin E) and *Cdkn2a* were inhibited by the NDF treatment (Fig. 1). Once *Tp53* induces *p21* transcription, it inhibits the cyclin–Cdk complex necessary for the G1-to-S-phase⁽²²⁾ and G2-to-M-phase transitions in colon cancer cells⁽²³⁾.

The retinoblastoma gene (*Rb1*) encodes a 105 kDa nuclear phosphoprotein, which in the non-phosphorylated state can bind and suppress the *E2f1* transcriptional factor, essential for

Table 1. Up-regulated genes in the colon distal tissue of rats treated with non-digestible fraction (NDF) + azoxymethane (AOM) compared with the AOM group*

Gene bank	Symbol	Description	Gene name	Fold change (> 2/up-regulation)	Fold change (> 1.1/up-regulation)
NM_024148	<i>Apex1</i>	DNA repair	APEX nuclease (multifunctional DNA repair enzyme) 1		+1.7
XM_216377	<i>Bag1</i>	Anti-apoptosis	Bcl2-associated athanogene 1	+13.7	
NM_017059	<i>Bax</i>	Induction of apoptosis	Bcl2-associated X protein	+3.5	
NM_022684	<i>Bid</i>	Induction of apoptosis	BH3-interacting domain death agonist		+1.1
NM_022274	<i>Birc5</i>	Anti-apoptosis	Baculoviral IAP repeat-containing 5	+3.7	
NM_053420	<i>Bnip3</i>	Induction of apoptosis	Bcl2/adenovirus E1B 19 kDa-interacting protein 3	+3.3	
NM_017259	<i>Btg2</i>	Negative regulation of cell proliferation	B-cell translocation gene 2, anti-proliferative		+1.2
NM_012923	<i>Ccng1</i>	Positive regulation of cell cycle	Cyclin G1	+31.1	
XM_223270	<i>Ccng2</i>	Positive regulation of cell cycle	Cyclin G2	+2.9	
NM_052981	<i>Ccnh</i>	Positive regulation of cell cycle	Cyclin H	+2.5	
NM_019296	<i>Cdc2</i>	Positive regulation of cell cycle	Cell division cycle 2, G1 to S and G2 to M		+1.9
NM_053593	<i>Cdk4</i>	Positive regulation of cell cycle	Cyclin-dependent kinase 4	+3.0	
NM_080782	<i>Cdkn1a</i>	Cell-cycle arrest	Cyclin-dependent kinase inhibitor 1A (p21, Cip1)	+5.5	
XM_235061	<i>Cradd</i>	Induction of apoptosis	CASP2 and RIPK1 domain containing adaptor with death domain	+2.7	
XM_225138	<i>Dapk1</i>	Positive regulation of cell cycle	Death-associated protein kinase 1	+2.0	
NM_053354	<i>Dnmt1</i>	DNA repair, gene silencing	DNA (cytosine-5)-methyltransferase 1	+9.3	
NM_012551	<i>Egr1</i>	Gene related to cell growth, proliferation and differentiation	Early growth response 1		+1.9
XM_215421	<i>Foxo3</i>	Induction of apoptosis and oxidative stress protection	Forkhead box O3	+2.4	
NM_024127	<i>Gadd45a</i>	Induction of apoptosis	Growth arrest and DNA-damage-inducible 45 α	+18.3	
NM_031515	<i>Kras</i>	Positive or negative regulation of cell proliferation	V-Ki-ras2 Kirsten rat sarcoma viral oncogene homologue	+5.5	
NM_021846	<i>Mcl1</i>	Anti-apoptosis	Myeloid cell leukaemia sequence 1	+7.3	
NM_031058	<i>Msh2</i>	DNA repair	MutS homologue 2 (<i>Escherichia coli</i>)		+1.8
XM_342346	<i>Nfkb1</i>	Positive or negative regulation of apoptosis, inflammatory process and cell proliferation	Nuclear factor of kappa light polypeptide gene enhancer in B-cells 1	+3.4	
NM_022381	<i>Pcna</i>	Cell proliferation regulation and DNA repair	Proliferating cell nuclear antigen	+4.6	
XM_213418	<i>Ppm1d</i>	Negative regulation of cell proliferation	Protein phosphatase 1D magnesium-dependent, delta isoform		+1.3
NM_031606	<i>Pten</i>	Negative regulation of cell cycle	Phosphatase and tensin homologue	+6.8	
XM_236927	<i>Parc</i>	Cell proliferation, cell cycle and apoptosis regulation	p53-associated Parkin-like cytoplasmic protein		+1.5
XM_232745	<i>Sfn</i>	Negative regulation of cell cycle	Stratifin	+6.7	
NM_032612	<i>Stat1</i>	Negative regulation of cell cycle	Signal transducer and activator of transcription 1	+4.2	
NM_012675	<i>Tnf</i>	Apoptosis, anti-apoptosis, inflammatory response, differentiation, proliferation and cell survival	TNF superfamily (member 2)	+2.5	
NM_030989	<i>Tp53</i>	Induction of apoptosis, negative regulation of cell cycle and DNA repair	Tumour protein p53	+9.3	
AI406530	<i>Traf1</i>	Induction of apoptosis	Transcribed locus, strongly similar to NP_033447.2 Tnf receptor-associated factor 1 (<i>Mus musculus</i>)	+2.3	
NM_019221	<i>Tp73l</i>	Induction of cell-cycle arrest and apoptosis	Tumour protein p73-like		+1.3
NM_022548	<i>Zmat3</i>	Negative regulation of cell cycle	Zinc finger, matrin type 3		+1.5
NM_001006999	<i>Xrcc4</i>	DNA repair	X-ray repair complementing defective repair in Chinese hamster cells 4		+1.2
NM_177419	<i>Xrcc5</i>	DNA repair	X-ray repair complementing defective repair in Chinese hamster cells 5	+3.2	

* Results were normalised to housekeeping genes, and values represent the degree of changes in mRNA for rats treated with NDF and AOM-induced relative to AOM-induced rats. $P \leq 0.05$ compared with the AOM group.

Table 2. Down-regulated genes in the colon distal tissue of rats treated with non-digestible fraction (NDF) + azoxymethane (AOM) compared with the AOM group*

Gene bank	Symbol	Description	Gene name	Fold change (<2/down-regulation)	Fold change (<1.1/down-regulation)
NM_023979	<i>Apaf1</i>	Positive regulation of apoptosis	Apoptotic peptidase activating factor 1		-1.2
XM_236275	<i>Atm</i>	Cell-cycle regulation, DNA damage detection and P53 stabilisation	Ataxia telangiectasia mutated homologue (human)		-1.4
NM_016993	<i>Bcl2</i>	Anti-apoptosis	B-cell chronic lymphocytic leukemia (CLL)/lymphoma 2	-3.5	
NM_012514	<i>Brca1</i>	Negative regulation of cell proliferation and cell cycle	Breast cancer 1		-1.6
NM_031542	<i>Brca2</i>	Cell-cycle regulation and chromosomal repair	Breast cancer 2		-1.6
NM_022522	<i>Casp2</i>	Induction of apoptosis	Caspase 2	-2.9	
NM_031632	<i>Casp9</i>	Induction of apoptosis	Caspase 9, apoptosis-related cysteine peptidase		-1.6
NM_001009470	<i>Ccnb2</i>	Positive control of cell cycle	Cyclin B2		-1.4
XM_342804	<i>Ccne2</i>	Positive control of cell cycle	Cyclin E2	-2.6	
NM_133571	<i>Cdc25a</i>	Positive control of cell cycle	Cell division cycle 25 homologue A (<i>Schizosaccharomyces pombe</i>)		-1.2
XM_226071	<i>Cdc25c</i>	Positive control of cell cycle	Cell division cycle 25 homologue C (<i>S. pombe</i>)	-9.2	
NM_031550	<i>Cdkn2a</i>	Cell-cycle arrest	Cyclin-dependent kinase inhibitor 2A	-2.4	
NM_080400	<i>Chek1</i>	Cell-cycle arrest	CHK1 checkpoint homologue (<i>S. pombe</i>)		-1.1
NM_053677	<i>Chek2</i>	Cell-cycle arrest	CHK2 checkpoint homologue (<i>S. pombe</i>)		-1.3
XM_215451	<i>Vcan</i>	Positive regulation of cell proliferation and anti-apoptosis	Versican	-2.0	
XM_230765	<i>E2f1</i>	Positive regulation of cell cycle and proliferation	E2F transcription factor 1	-18.4	
XM_576312	<i>Ep300</i>	Cell-cycle regulation and transcriptional co-activator	E1A binding protein p300		-1.5
NM_012689	<i>Esr1</i>	Cell growth and differentiation	Estrogen receptor 1	-2.0	
NM_152937	<i>Fadd</i>	Induction of apoptosis	Fas (TNFRSF6)-associated via death domain		-1.3
NM_012908	<i>Faslg</i>	Induction of apoptosis	Fas ligand (TNF superfamily, member 6)	-2.0	
NM_012589	<i>Il6</i>	Positive regulation of cell proliferation and inflammatory response	IL6		-1.5
NM_021835	<i>Jun</i>	Gene related to cell growth, proliferation and differentiation	Jun oncogene	-13.7	
XM_225045	<i>Lig4</i>	DNA repair	Ligase IV, DNA, ATP-dependent		-1.7
XM_346005	<i>LOC367198</i>	Cell-cycle regulation and DNA damage detection	Similar to serine/threonine-protein kinase ATR (ataxia telangiectasia and Rad3-related protein)	-6.8	
NM_176079	<i>Myod1</i>	Cell growth and differentiation	Myogenic differentiation 1	-11.8	
XM_218820	<i>Prc1</i>	Gene related to cell cycle	Protein regulator of cytokinesis 1		-1.9
NM_022391	<i>Pttg1</i>	Gene related to cell growth, proliferation and differentiation	Pituitary tumour-transforming 1		-1.3
XM_344434	<i>Rb1</i>	Cell-cycle control	Retinoblastoma 1		-1.5
XM_228273	<i>Rev3l</i>	DNA repair	REV3-like, catalytic subunit of DNA polymerase zeta (yeast)		-1.7
XM_578496	<i>RGD1566319</i>	DNA damage response and oxidative stress	Similar to Sestrin 2 (Hi95)		-1.7
XM_001055762	<i>Rprm</i>	Cell-cycle arrest	Reprimo, TP53-dependent G2 arrest mediator candidate	-3.3	
XM_228146	<i>Sirt1</i>	Epigenetic regulation of transcription	Sirtuin (silent mating type information regulation 2 homologue) 1 D47 (<i>Saccharomyces cerevisiae</i>)		-1.2
XM_344431	<i>Tnfrsf10b</i>	Induction of apoptosis	TNF receptor superfamily, member 10b	-2.0	
XM_223012	<i>Tp53bp2</i>	Gene related to apoptosis and cell growth	Tumour protein p53 binding protein, 2	-2.3	
XM_342992	<i>Tp73</i>	Induction of cell-cycle arrest and apoptosis	Tumour protein p73	-12.0	
NM_031534	<i>Wt1</i>	Negative regulation of cell cycle	Wilms tumour 1	-2.6	

Beans modulate signalling pathway genes

S149

* Results were normalised to housekeeping genes, and values represent the degree of changes in mRNA for rats treated with NDF and AOM-induced relative to AOM-induced rats. $P \leq 0.05$ compared with the AOM group.

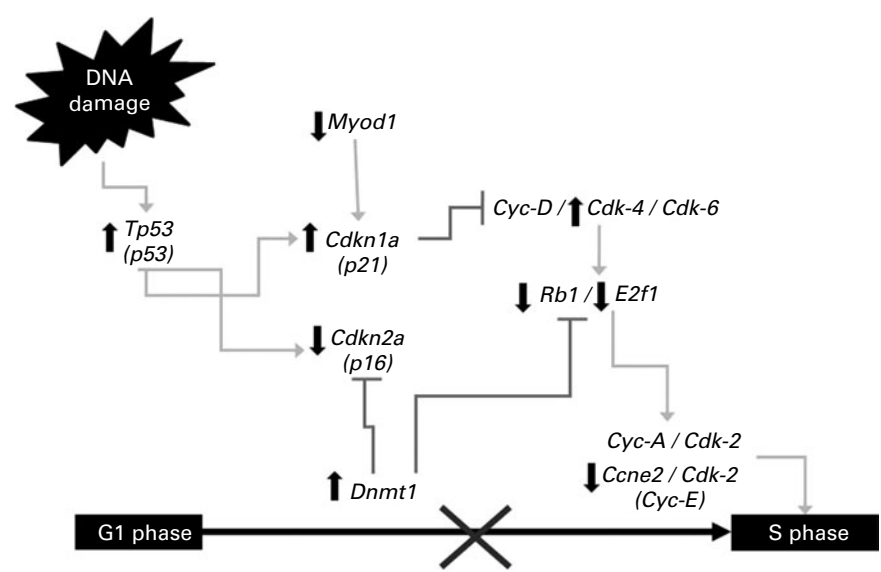

Fig. 1. Changes in gene expression in the G1/S cell-cycle phase. Symbols indicate up-regulation (↑) and down-regulation (↓) in mRNA expression as derived from array analysis, and signalling pathway interruption (x).

the G1-to-S-phase transition⁽²⁴⁾. Both genes were down-regulated by the NDF treatment compared with the AOM group. The *p21*, *Ccne2*, *Rb1* and *E2f1* regulation suggests a possible cell-cycle arrest in the G1/S phase induced by the NDF treatment (Fig. 1). The change in *p21* and *Rb1* expression is consistent with cell-cycle arrest at the G1 phase in the distal colon of AOM-induced rats by the treatment of a polysaccharide extract obtained from black bean cv. Negro 8025, reported by Feregrino-Perez *et al.*⁽¹³⁾. On the other hand, oligosaccharides have been reported to induce cell-cycle arrest in different cell lines of human colon cancer through the regulation of *p21*, cyclins and some kinase expression⁽¹²⁾. The NDF treatment contains considerable amounts of oligosaccharides (raffinose, stachyose and verbascose) quantified by HPLC⁽⁷⁾, and these compounds probably influence cell-cycle arrest by modulating these genes.

Moreover, another methyltransferase gene, *Dnmt1*, overexpressed in the NDF + AOM group compared with the AOM group (Fig. 1), was able to inhibit gene transcription involved in proliferation and cell-cycle progression⁽²⁵⁾. *Cdkn2a* suppressed in this study also suggest *Dnmt1* association with gene silencing by DNA methylation for the gene promoter regions of *Cdkn2a*⁽²⁶⁾. Furthermore, the *Myod1* gene participating in apoptosis and cell differentiation⁽²⁷⁾ was also suppressed, thereby demonstrating that it could be highly methylated and therefore silenced^(28,29).

Tp53 transcriptionally suppresses key regulators such as *Cdc25c* and *Ccnb2*, cyclin that complexes with *Cdc2* to induce mitosis, and this inhibition promotes cell-cycle arrest before the cell enters mitosis⁽³⁰⁾. In the present study, *Ccnb2* and *Cdc25c* were suppressed, probably resulting in cell-cycle arrest at the G2/M phase (Fig. 2). *Gadd45a* gene transcription also activated by *Tp53* acts as a control point in the G2/M

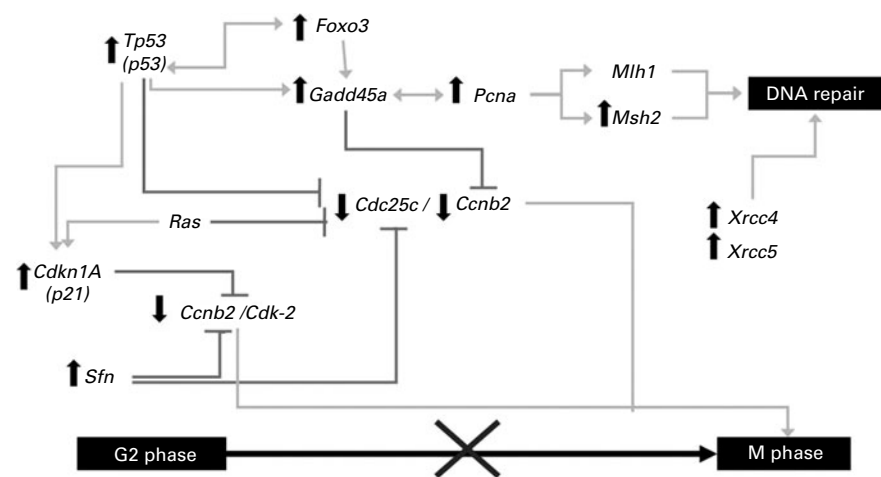

Fig. 2. Changes in gene expression in the G2/M cell-cycle phase and DNA repair. Symbols indicate up-regulation (↑) and down-regulation (↓) in mRNA expression as derived from array analysis, and signalling pathway interruption (x).

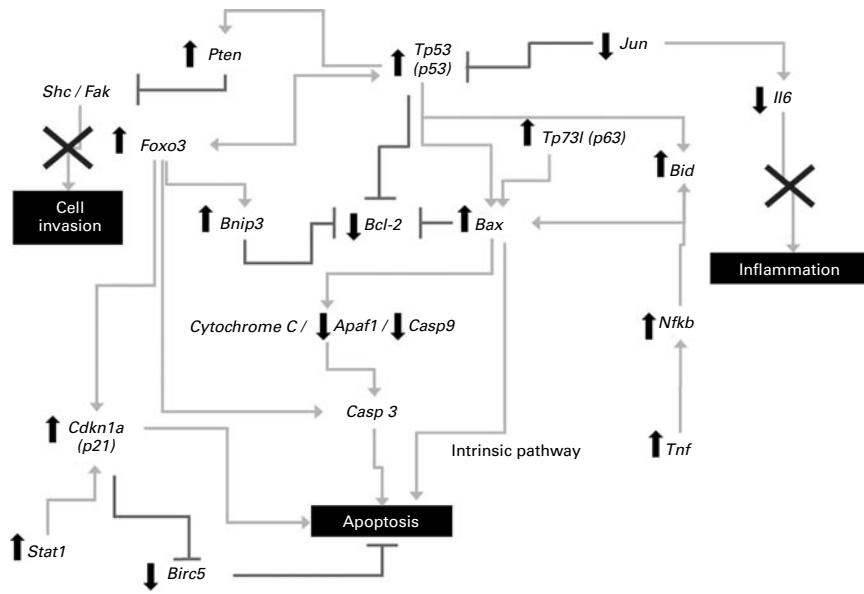

Fig. 3. Changes in gene expression in apoptosis and inflammatory pathways. Symbols indicate up-regulation (↑) and down-regulation (↓) in mRNA expression as derived from array analysis, and signalling pathway interruption (X).

transition of the cell cycle, contributing to *Ccnb2* inhibition⁽³¹⁾. *Gadd45a* has also been implicated in excision DNA repair through the interaction with proliferation cell nuclear antigen (*Pcna*)⁽³²⁾. This gene was overexpressed by the NDF treatment, suggesting that both overexpression and interaction confer important protective mechanisms against aberrant crypt foci development involving DNA repair. *Pcna* interacts with *Msb2* at the early stages of the DNA repair process by recognising loss bases⁽³³⁾, and it was up-regulated by the NDF. In addition, the NDF also induced *Xrcc5*, a gene involved in repairing the double-strand break DNA molecule by directly binding to DNA and recruiting other repair proteins⁽³⁴⁾. These results support the potential induction of DNA repair by the NDF due to synergism among different genes mentioned as an alternative protective mechanism.

The product of the *Sfn* gene (14-3-3-σ), implicated in cell-cycle arrest between the G2 and M phase⁽³⁵⁾, can bind and inhibit several cyclin-dependent kinases (*Cdk2*, *Cdc2* and *Cdk4*) and Cyclin B1 and 2⁽³⁶⁾, and inactivate *Cdc25c*, which is inhibited by the NDF, preventing mitosis initiation. *Sfn* was induced by the NDF (Fig. 2), suggesting that modulation of this gene could contribute to cell-cycle arrest in the G2/M phase through *Ccnb2*, *Cdc25c* and *Gadd45a*⁽³⁷⁾.

The *Foxo3* gene, mediating cell proliferation, survival, differentiation, DNA repair and defence against oxidative stress⁽³⁸⁾, was enhanced by the NDF (Fig. 2). *Foxo3* induces *Gadd45a*, *Cdkn1a* and *Bnip3* transcription^(38,39), which suggests that overexpression of these genes in the present study may also be induced through the direct action of *Foxo3*, functioning as a transcription factor or promoting the activity and stability of *Tp53*, as reported in other studies⁽⁴⁰⁾.

Ras can lead the process normally associated with the acquisition of a transformed phenotype or promote growth detention by cell-cycle arrest and cell death by apoptosis. The NDF increased *Ras* expression compared with the AOM group

(Fig. 3), presumably to induce *Cdkn1a* (*p21*) expression and decrease *Cdc25* mediated by *Ras*⁽⁴¹⁾.

Tp53 is also a key transcription factor inducing apoptosis by modulating several genes involved directly or indirectly in molecular pathways resulting in programmed cell death⁽⁴²⁾. The NDF induced various genes involved in apoptosis. The apoptosis intrinsic pathway was modulated by the pro-apoptotic genes *Bax* and *Bnip3*, which in turn suppress the anti-apoptotic gene *Bcl2* (Fig. 3). The *Bax*:*Bcl2* ratio determines the susceptibility of a cell to die by apoptosis by mitochondrial membrane depolarisation^(43,44), and *Bnip3* directly inhibits *Bcl2* after activation by intracellular death signals⁽⁴⁵⁾.

Once cytochrome *c* is liberated into the cytosol from the mitochondria, it forms a complex with *Apaf1* and *Casp9* called apoptosome, which activates *Casp3*, an enzyme responsible for DNA fragmentation and cell death by apoptosis⁽⁴⁶⁾. In the present study, *Apaf1*, *Casp2* and *Casp9* were down-regulated, suggesting that apoptosis induction can be carried out by cytochrome *c* but independent of *Casp2* and *Casp9* activation, as evidenced by Marsden *et al.*⁽⁴⁷⁾. *Casp2* and *Casp9* are not essential to induce apoptosis in thymocytes 2^{-/-}9^{-/-} cell, since the death process presented the same characteristics of apoptosis and probably death involved the action of other caspases. We suggest that apoptosis is triggered by *Casp3* activation directly through cytochrome *c* or by a previously proposed caspase-independent path⁽⁴⁸⁾. Shrivastava *et al.*⁽⁴⁸⁾ suggested that iodine-induced apoptosis on MCF-7 cells (cells without a functional caspase-3 expression) is independent of caspase activation and involves the loss of membrane polarity, increases *Bax* expression, decreases *Bcl2* expression and releases an apoptosis-inducing factor from the mitochondrial membrane. The release of an apoptosis-inducing factor, Smac/DIABLO, HtrA2/Omi or Endo G, from the mitochondrial membrane induces cell death independently of caspases⁽⁴⁹⁾.

Bax induction and *Bcl2* inhibition by the NDF of common bean cv. Bayo Madero are in agreement with the effect of polysaccharides of bean cv. Negro 8025 in AOM-induced rats observed by Feregrino-Perez *et al.*⁽¹³⁾. Moreover, the NDF of Bayo Madero induced *Bid* expression, suggesting that this gene could activate other caspases (Fig. 3). Modulation of the *Bax*, *Bnip3*, *Bid* and *Bcl2* genes suggests a potential effect of the NDF on cell death activation by apoptosis. Yu *et al.*⁽⁵⁰⁾ showed that *Bax* mRNA was overexpressed and *Bcl2* repressed in HT-29 cells by genistein, an isoflavone, in a dose-dependent manner. The NDF of Bayo Madero contains phenolic compounds and condensed tannins⁽⁷⁾ that can partly reach the colon intact and exert protective effects on the cell in that organ.

Another pathway to promote apoptosis could be induced by *Stat1* that was overexpressed in the NDF + AOM group (Fig. 3). *Stat1* is an important gene that optimally triggers apoptosis by multiple stimuli through *p21* induction, involving cytochrome *c* release and *Casp3* activation⁽⁵¹⁾.

Gene induction of different molecular pathways can also be modulated by two other members, *Tp731* (*p63*) and *Tp73*, of *Tp53* superfamily transcription factors, whose functions are similar, but not identical, to *Tp53*⁽⁵²⁾. *Tp731* and *Tp73* were up- and down-regulated, respectively (Fig. 3), suggesting that at least *p63* (overexpressed) contributed to the induction of DNA repair genes, enhancing the apoptotic effects of *Tp53*⁽⁵³⁾ resulting in chemoprotection by the NDF from common beans.

Pten is involved in cell adhesion, migration and invasion by inhibiting the adapter protein *Shc* and the kinase protein of focal adhesion *Fak*⁽⁵⁴⁾. In the present study, the NDF induced *Pten* expression (Fig. 3), suggesting that its chemopreventive effect could be promoted by avoiding cell signalling, and the damage generated by AOM was not extended to other cells.

Nfkb1 is a key gene in the innate inflammatory response and cell survival. However, this gene has a paradoxical role because it also exerts a pro-apoptotic function, under certain circumstances, through the induction of some genes such as *Tnf* death receptors⁽⁵⁵⁾ and *Tp53* expression and stabilisation by initiating the apoptosis signalling cascade⁽⁵⁶⁾ (Fig. 3). The NDF induced *Nfkb1* and *Tnf* expression in AOM-induced rats, indicating the contribution of *Nfkb1* to trigger apoptosis through *Tnf* death receptors indirectly by *Tp53* induction. These data suggest that both mechanisms could be activated by *Nfkb1* at the early stage of colon cancer and the gene probably has not yet suffered any mutations or aberrations that block its pro-apoptotic activity, becoming a potential anti-apoptotic function, as suggested by Wu & Miyamoto⁽⁵⁷⁾.

Jun antagonises the pro-apoptotic and anti-proliferative activity of *Tp53* in the initiation stage of cancer development⁽⁵⁸⁾. The phosphorylation of *Jun* by c-Jun N-terminal kinase leads to the activation of the *Il6* gene⁽⁵⁹⁾, which is normally induced in the inflammatory response⁽⁶⁰⁾. The NDF suppressed *Jun* and *Il6* in the present study (Fig. 3), indicating that the NDF treatment presumably protects against an inflammatory response by inhibiting the pro-inflammatory pathway mediated by *Il6*.

Tissue response to aggression caused by AOM and the protection provided by the NDF from common bean cv. Bayo Madero also showed some contradictions. Examples of such events are as follows: *Bag1* overexpression, an important

gene for tumour growth and progression⁽⁶¹⁾; *Birc5* (survivin) induction, an important inhibitor of apoptosis and a proliferation promoter in colorectal cancer⁽⁶²⁾; *Rprm* inhibition, a gene that induces cell-cycle arrest between the G2 and M phase, regulating *Cdc2* and Cyclin B1 activity⁽⁶³⁾. The activation of contradictory events of signalling pathways and the dynamic balance between them may be important for cell survival or apoptosis. This issue is a matter of each individual cell, since each cell responds to damage and achieves a physiological state by either apoptosis or survival^(64,65). Moreover, the unexpected overexpression of oncogenes and the decreased expression of tumour-suppressor genes may also reflect the analysis of different cell types along the crypts. In a normal colon, morphogenesis genes involved in cell cycle and proliferation are mainly expressed at the crypt base, whereas apoptosis-inducing genes are expressed at the crypt top, and the results obtained from the PCR array represent the sum of gene expression along the crypt⁽⁶⁶⁾.

In conclusion, the present study describes changes in gene expression profile in the distal colon tissue of AOM-induced rats in response to treatment with the NDF of common bean cv. Bayo Madero at an early stage of colon cancer. Additionally, the present study proposes the scientific basis by which the NDF has a chemopreventive effect against colon cancer development through modulating different molecular mechanisms such as apoptosis induction, cell-cycle arrest, inhibition of cell proliferation and inflammation and induction of DNA repair (Figs. 1–3).

Acknowledgements

The present study was supported by the Consejo Nacional de Ciencia y Tecnologia (CONACYT), grant no. 57536. We thank Virginia Dickison for technical support with quantitative PCR arrays and the Instituto Nacional de Investigaciones Forestales Agrícolas y Pecuarias, the Bajio Station (INIFAP, Celaya). V.-C. H. designed and conducted the research, analysed the data and wrote the paper; G.-G. R. provided technical support and supplied material for RNA extraction, cDNA synthesis and PCR arrays; G.-O. L. provided technical support and supplied material for RNA extraction and cDNA synthesis; O. B. D. supplied material for PCR arrays; R.-C. R. provided technical support; W. P. provided technical support and supplied material for PCR arrays; L.-P. G. designed and supervised the trial as principal investigator, and participated in drafting and revising the manuscript. All authors contributed to the data interpretation and approved the final version of the manuscript. There are no conflicts of interest.

References

1. Jemal A, Siegel R, Ward E, *et al.* (2006) Cancer statistics, 2006. *CA Cancer J Clin* **56**, 106–130.
2. Jemal A, Siegel R, Xu J, *et al.* (2010) Cancer statistics, 2010. *CA Cancer J Clin* **60**, 277–300.
3. Instituto Nacional de Estadísticas, Geografía e Informática (2008), Mexico. Información sobre Tumores Malignos (*National Institute of Statistics, Geography and Informatics*,

- Mexico. *Information on Malignant Tumors*): INEGI. <http://www.inegi.org.mx>.
4. Michels KB (2005) The role of nutrition in cancer development and prevention. *Int J Cancer* **114**, 163–165.
 5. Millen AE, Subar AF, Grawbard BI, *et al.* (2007) Fruit and vegetable intake and prevalence of colorectal adenoma in a cancer screening trial. *Am J Clin Nutr* **86**, 1754–1764.
 6. Lanza E, Hartman TJ, Albert PS, *et al.* (2006) High dry bean intake and reduced risk of advanced colorectal adenoma recurrence among participants in the Polyp Prevention Trial. *J Nutr* **136**, 1896–1903.
 7. Vergara-Castañeda HA, Guevara-Gonzalez RG, Ramos-Gómez M, *et al.* (2010) Non-digestible fraction of cooked bean (*Phaseolus vulgaris* L.) cultivar Bayo Madero suppresses colonic aberrant crypt foci in azoxymethane-induced rats. *Food Funct* **1**, 294–300.
 8. Torruco-Uco J, Chel-Guerrero L, Martínez-Ayala A, *et al.* (2009) Angiotensin-I converting enzyme inhibitory and antioxidant activities of protein hydrolysates from *Phaseolus lunatus* and *Phaseolus vulgaris* seeds. *Food Sci Technol* **42**, 1597–1604.
 9. Campos-Vega R, Reynoso-Camacho R, Pedraza-Aboytes G, *et al.* (2009) Chemical composition and *in vitro* polysaccharide fermentation of different beans (*Phaseolus vulgaris* L.). *J Food Sci* **74**, 59–65.
 10. Chen J, Ghazawi FM, Bakkar W, *et al.* (2006) Valproic acid and butyrate induce apoptosis in human cancer cells through inhibition of gene expression of Akt/protein kinase B. *Mol Cancer* **5**, 71.
 11. Veeriah S, Hofmann T, Gleis M, *et al.* (2007) Apple polyphenols and products formed in the gut differently inhibit survival of human cell lines derived from colon adenoma (LT97) and carcinoma (HT29). *J Agric Food Chem* **55**, 2892–2900.
 12. Kuntz S, Kunz C & Rudloff S (2009) Oligosaccharides from human milk induce growth arrest via G2/M by influencing growth-related cell cycle genes in intestinal epithelial cells. *Br J Nutr* **101**, 1306–1315.
 13. Feregrino-Pérez AA, Berumen LC, García-Alcocer G, *et al.* (2008) Composition and chemopreventive effect of polysaccharides from common beans (*Phaseolus vulgaris* L.) on azoxymethane-induced colon cancer. *J Agric Food Chem* **56**, 8737–8744.
 14. Campos-Vega R, Guevara-Gonzalez RG, Guevara-Olvera BL, *et al.* (2010) Bean (*Phaseolus vulgaris* L.) polysaccharides modulate gene expression in human colon cancer cells (HT-29). *Food Res Int* **43**, 1057–1064.
 15. Aparicio-Fernández XO, Manzo-Bonilla L & Loarca-Piña GF (2005) Comparison of antimutagenic activity of phenolic compounds in newly harvested and stored common beans *Phaseolus vulgaris* against aflatoxin B₁. *J Food Sci* **70**, S73–S78.
 16. Kurtzman RH & Hallbrook WU (1970) Polysaccharide from dry navy beans, *Phaseolus vulgaris*: its isolation and stimulation of clostridium perfringens. *Appl Microbiol* **20**, 715–719.
 17. Del Razo LM, Garcia-Vargas GG, Garcia-Salcedo J, *et al.* (2002) Arsenic levels in cooked food and assessment of adult dietary intake of arsenic in the Region Lagunera, Mexico. *Food Chem Toxicol* **40**, 1423–1431.
 18. Ho J & Benchimol S (2003) Transcriptional repression mediated by the p53 tumour suppressor. *Cell Death Differ* **10**, 404–408.
 19. Rahman-Roblick R, Roblick UJ, Hellman U, *et al.* (2007) p53 targets identified by protein expression profiling. *PNAS* **104**, 5401–5406.
 20. Li L, Rao JN, Guo X, *et al.* (2001) Polyamine depletion stabilizes p53 resulting in inhibition of normal intestinal epithelial cell proliferation. *Am J Physiol Cell Physiol* **281**, 941–953.
 21. Mahyar-Roemer M & Roemer K (2001) p21 Waf1/Cip1 can protect human colon carcinoma cells against p53-dependent and p53-independent apoptosis induced by natural chemopreventive and therapeutic agents. *Oncogene* **20**, 3387–3398.
 22. Damia G & Brogini M (2004) Cell cycle checkpoint proteins and cellular response to treatment by anticancer agents. *Cell Cycle* **3**, 46–50.
 23. Maeda T, Chong MT, Espino RA, *et al.* (2002) Role of p21Waf-1 in regulating the G1 and G2/M checkpoints in ultraviolet-irradiated keratinocytes. *J Invest Dermatol* **119**, 513–521.
 24. Fojer F & Te Riele H (2006) Restriction beyond the restriction point: mitogen requirement for G2 passage. *Cell Div* **1**, 1–5.
 25. Robertson KD, Ait-Si-Ali S, Yokochi T, *et al.* (2000) DNMT1 forms a complex with Rb, E2F1 and HDAC1 and represses transcription from E2F-responsive promoters. *Nat Genet* **25**, 338–342.
 26. Robert MF, Morin S, Beaulieu N, *et al.* (2003) DNMT1 is required to maintain CpG methylation and aberrant gene silencing in human cancer cells. *Nat Genet* **33**, 61–65.
 27. Harford TJ, Shaltouki A & Weyman CM (2010) Increased expression of the pro-apoptotic Bcl2 family member PUMA and apoptosis by the muscle regulatory transcription factor MyoD in response to a variety of stimuli. *Apoptosis* **15**, 71–82.
 28. Kawakami K, Ruzskiewicz A, Bennett G, *et al.* (2006) DNA hypermethylation in the normal colonic mucosa of patients with colorectal cancer. *Br J Cancer* **94**, 593–598.
 29. Hiranuma C, Kawakami K, Oyama K, *et al.* (2004) Hypermethylation of the *MYOD1* gene is a novel prognostic factor in patients with colorectal cancer. *Int J Mol Med* **13**, 413–417.
 30. Imbriano C, Gurtner A, Cocchiarella F, *et al.* (2005) Direct p53 transcriptional repression: *in vivo* analysis of CCAAT-containing G2/M promoters. *Mol Cell Biol* **25**, 3737–3751.
 31. Hildesheim J & Fornace AJ (2002) Gadd45a: an elusive yet attractive candidate gene in pancreatic cancer. *Clin Cancer Res* **8**, 2475–2479.
 32. Jung HJ, Kim EH, Mun JY, *et al.* (2007) Base excision DNA repair defect in Gadd45a-deficient cells. *Oncogene* **26**, 7517–7525.
 33. Li M, Liu L, Wang Z, *et al.* (2008) Overexpression of hMSH2 and hMLH1 protein in certain gastric cancers and their surrounding mucosae. *Oncol Rep* **19**, 401–406.
 34. Sengupta S & Roychoudhury S (2005) DNA double strand break and repair: mechanisms and involvement in human cancer. *Int J Hum Genet* **5**, 1–10.
 35. Hermeking H, Lengauer C, Polyak K, *et al.* (1997) 14-3-3 sigma is a p53-regulated inhibitor of G2/M progression. *Mol Cell* **1**, 3–11.
 36. Laronga C, Yang HY, Neal C, *et al.* (2000) Association of the cyclin-dependent kinases and 14-3-3 sigma negatively regulates cell cycle progression. *J Biol Chem* **275**, 23106–23112.
 37. Luk SCW, Siu SWF, Lai CK, *et al.* (2005) Cell cycle arrest by a natural product via G2/M checkpoint. *Int J Med Sci* **2**, 64–69.
 38. Lam EWF, Francis RE & Petkovic M (2006) FOXO transcription factors: key regulators of cell fate. *Biochem Soc Trans* **34**, 722–726.
 39. Greer EL & Brunet A (2005) FOXO transcription factors at the interface between longevity and tumor suppression. *Oncogene* **24**, 7410–7425.

40. You H, Yamamoto K & Mak TW (2006) Regulation of transactivation-independent proapoptotic activity of p53 by FOXO3a. *PNAS* **103**, 9051–9056.
41. Frame S & Balmain A (2000) Integration of positive and negative growth signals during Ras pathway activation *in vivo*. *Curr Opin Genet Dev* **10**, 06–113.
42. O'Brate A & Giannakakou P (2003) The importance of p53 location: nuclear or cytoplasmic zip code? Bax-induced apoptotic cell death. *Drug Resist Updat* **6**, 313–322.
43. Pawlowski J & Kraft AS (2000) Bax-induced apoptotic cell death. *PNAS* **97**, 529–531.
44. Bai J & Meng Z (2005) Expression of apoptosis-related genes in livers from rats exposed to sulfur dioxide. *Toxicology* **216**, 253–260.
45. Ray R, Chen G, Velde CV, *et al.* (2000) BNIP3 heterodimerizes with Bcl-2/Bcl-XL and induces cell death independent of a Bcl-2 homology 3 (BH3) domain at both mitochondrial and nonmitochondrial sites. *J Biol Chem* **275**, 1439–1448.
46. Chen L, Willis SN, Wei A, *et al.* (2005) Differential targeting of prosurvival Bcl-2 proteins by their BH3-only ligands allows complementary apoptotic function. *Mol Cell* **17**, 393–403.
47. Marsden VS, Ekert PG, Van Delft M, *et al.* (2004) Bcl-2-regulated apoptosis and cytochrome *c* release can occur independently of both caspase-2 and caspase-9. *J Cell Biol* **165**, 775–780.
48. Shrivastava A, Tiwari M, Sinha RA, *et al.* (2006) Molecular iodine induces caspase-independent apoptosis in human breast carcinoma cells involving the mitochondria-mediated pathway. *J Biol Chem* **281**, 19762–19771.
49. Ravagnan L, Roumier T & Kroemer G (2002) Mitochondria, the killer organelles and their weapons. *J Cell Physiol* **192**, 131–137.
50. Yu Z, Li W & Liu F (2004) Inhibition of proliferation and induction of apoptosis by genistein in colon cancer HT-29 cells. *Cancer Lett* **215**, 159–166.
51. Agrawal S, Agarwal ML, Chatterjee-Kishore M, *et al.* (2002) Stat1-dependent, p53-independent expression of p21waf1 modulates oxysterol-induced apoptosis. *Mol Cell Biol* **22**, 1981–1992.
52. Lin YL, Sengupta S, Gurdziel K, *et al.* (2009) p63 and p73 transcriptionally regulate genes involved in DNA repair. *PLoS Genet* **5**, 1–13.
53. Flores ER, Tsai KY, Crowley D, *et al.* (2002) p63 and p73 are required for p53-dependent apoptosis in response to DNA damage. *Nature* **416**, 560–564.
54. Haier J & Nicolson GL (2002) PTEN regulates tumor cell adhesion of colon carcinoma cells under dynamic conditions of fluid flow. *Oncogene* **21**, 1450–1460.
55. Campbell KJ, Rocha S & Perkins ND (2004) Active repression of antiapoptotic gene expression by RelA (p65) NF- κ B. *Mol Cell* **13**, 853–865.
56. Fujioka S, Schmidt C, Scwabas GM, *et al.* (2004) Stabilization of p53 is a novel mechanism for proapoptotic function of NF- κ B. *J Biol Chem* **279**, 27549–27559.
57. Wu ZH & Miyamoto S (2008) Induction of a pro-apoptotic ATM-NF- κ B pathway and its repression by ATR in response to replication stress. *EMBO J* **27**, 1963–1973.
58. Maeda S & Karin M (2003) Oncogene at last c-Jun promotes liver cancer in mice. *Cancer Cell* **3**, 102–104.
59. Cahill CM & Rogers JT (2008) Interleukin (IL) 1 β induction of IL-6 is mediated by a novel phosphatidylinositol 3-kinase-dependent AKT/I β kinase α pathway targeting activator protein-1. *J Biol Chem* **283**, 25900–25912.
60. Ahn KS & Aggarwal BB (2005) Transcription factor NF- κ B. A sensor for smoke and stress signals. *Ann NY Acad Sci* **1056**, 218–233.
61. Clemler NK, Collard TJ, Southern SL, *et al.* (2008) BAG-1 is up-regulated in colorectal tumour progression and promotes colorectal tumour cell survival through increased NF- κ B activity. *Carcinogenesis* **29**, 849–857.
62. Chen WC, Liu Q, Fu XJ, *et al.* (2004) Expression of survivin and its significance in colorectal cancer. *World J Gastroenterol* **10**, 2886–2889.
63. Ohki R, Nemoto J, Murasawa H, *et al.* (2004) Reprimo, a new candidate mediator of the p53-mediated cell cycle arrest at the G2 phase. *J Biol Chem* **275**, 22627–22630.
64. Nair VD, Yuen T, Olanow CW, *et al.* (2004) Early single cell bifurcation of pro- and antiapoptotic states during oxidative stress. *J Biol Chem* **279**, 27494–27501.
65. Iacomino G, Tecce MF, Grimaldi C, *et al.* (2001) Transcriptional response of a human colon adenocarcinoma cell line to sodium butyrate. *Biochem Biophys Res Commun* **285**, 1280–1289.
66. Kosinski C, Li VSW, Chan ASY, *et al.* (2007) Gene expression patterns of human colon tops and basal crypts and BMP antagonists as intestinal stem cell niche factors. *PNAS* **104**, 15418–15423.